

BCSF-D ULTIMA Series

Mini VRF Outdoor Unit
Technical Manual

220~240V/1/50Hz

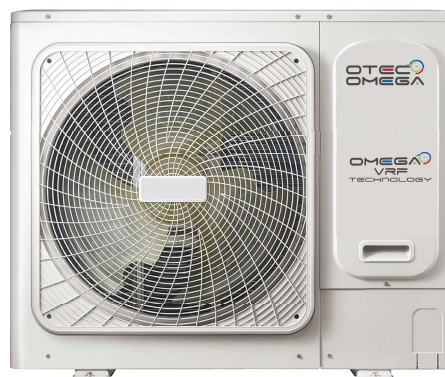
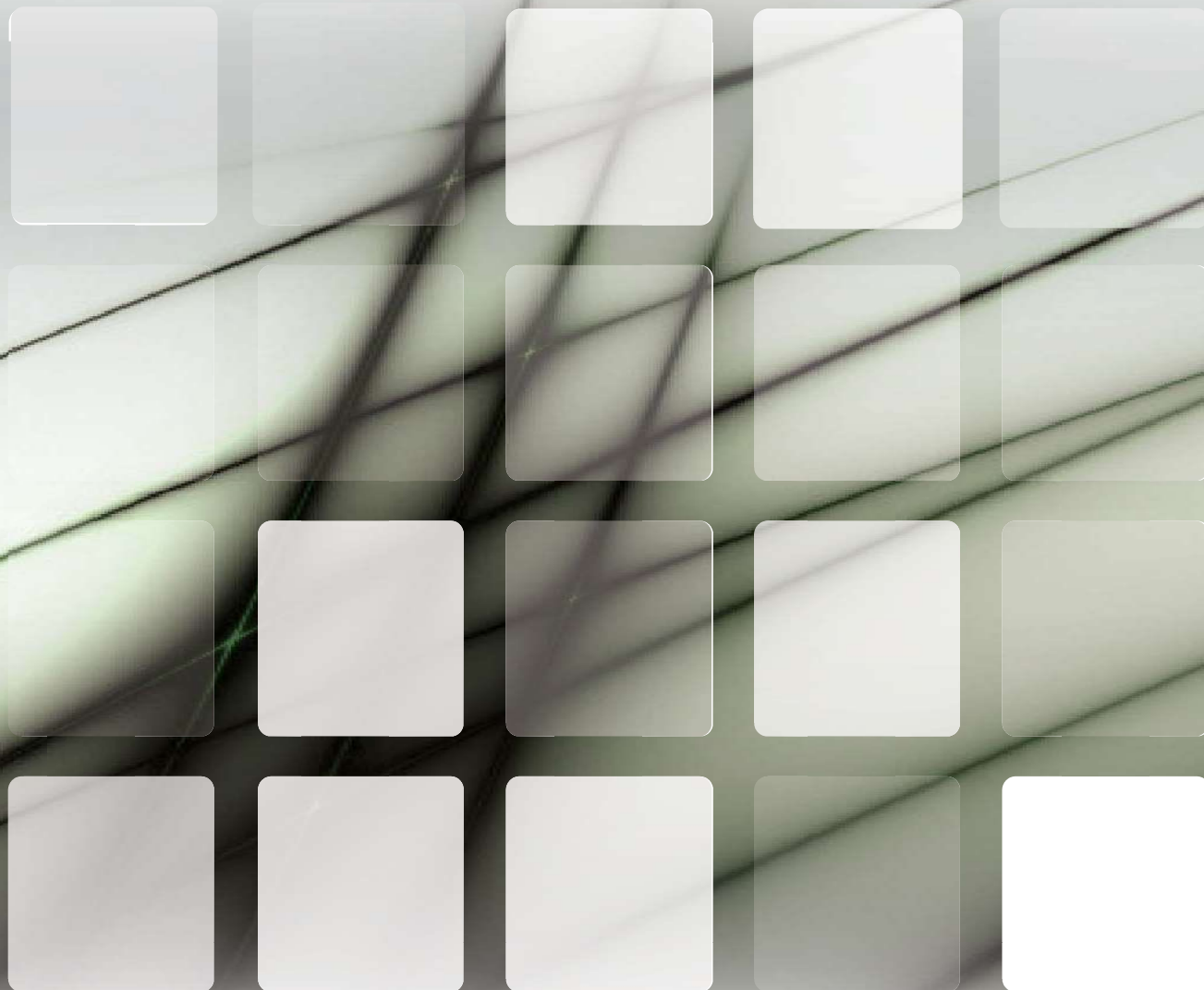

CONTENTS

Part 1 General Information.....	3
Part 2 Outdoor Unit Engineering Data	13
Part 3 System Design and Installation.....	69

Part 1

General Information

1	Indoor and Outdoor Unit Capacities.....	4
2	External Appearance.....	5
3	Nomenclature.....	6
4	Combination Ratio.....	7
5	Selection Procedure.....	8

1 Indoor and Outdoor Unit Capacities

1.1 Indoor Units

Table 1-1.1: Indoor unit abbreviation codes

Abbreviation code	Type
BECW	One-way Cassette
BECM	Compact Four-way Cassette
BECS	Four-way Cassette
BEMP	Medium Static Pressure Duct
BEWM	Wall-mounted

Table 1-1.2: Indoor unit capacity range

Capacity			Capacity index	BECW	BECM	BECS	BEMP	BEWM
kBtu/h	kW	HP						
6	1.8	0.6	6	6	—	—	—	—
7	2.2	0.8	7	7	7	—	7	7
9	2.8	1	9	9	9	9	9	9
12	3.6	1.25	12	12	12	12	12	12
15	4.5	1.6	15	15	15	15	15	15
18	5.6	2	18	18	—	18	18	18
24	7.1	2.5	24	24	—	24	24	24
28	8.0	3	28	—	—	28	28	28
32	9.0	3.2	32	—	—	32	32	32
36	10.0	3.6	36	—	—	36	—	—
40	11.2	4	40	—	—	40	40	—
48	14.0	5	48	—	—	48	48	—
56	16.0	6	56	—	—	—	56	—

Notes:

1. ULTIMA series indoor units could connect to ULTIMA series outdoor units.

1.2 Outdoor Units

Table 1-1.3: Outdoor unit capacity range

Nominal Cooling Capacity (kBtu/h)	Model Name
30.7	BCSF030N0A4-DTM090
37.5	BCSF040N0A6-DTM115
47.8	BCSF050N0A7-DTM140
54.6	BCSF060N0A8-DTM160
64.8	BCSF070N0A9-DTM190

Notes:

1. ULTIMA series outdoor units could not be combined.

2 External Appearance



2.1 Indoor Units

Table 1-2.1: Indoor unit appearance

<p>One-way Cassette</p> 	<p>Four-way Cassette</p> 
<p>Compact Four-way Cassette</p> 	<p>Wall-mounted</p> 
<p>Medium Static Pressure Duct</p> 	

2.2 Outdoor Units

Table 1-2.2: Outdoor unit appearance

30/40/50 Models	60/70 Models
	

4 Combination Ratio

$$\text{Combination ratio} = \frac{\text{Sum of capacity indexes of the indoor units}}{\text{Capacity index of the outdoor unit}}$$

Table 1-4.1: Indoor and outdoor unit combination ratio limitations

Type	Minimum combination ratio	Maximum combination ratio
ULTIMA Series outdoor units	45%	130%

Table 1-4.2: Combinations of Indoor and outdoor units

Outdoor unit capacity		Sum of capacity indexes of connected indoor units (standard indoor units only)	Number of connected indoor units
kBtu/h	Capacity index		
30.7	28	12.6 to 36.4	1-4
37.5	36	16.2 to 46.8	1-6
47.8	42	18.9 to 54.6	1-7
54.6	48	21.6 to 62.4	1-8
64.8	56	25.2 to 72.8	1-9

5 Selection Procedure

5.1 Procedure

Step 1: Establish design conditions

Design temperature and humidity (indoor and outdoor)
 Required heat load of each room
 System peak load
 Piping length, level differences
 Indoor unit specifications (type and quantity)

Step 2: Select indoor units

Decide indoor unit safety factor

Select indoor unit models ensuring that:
 Indoor unit capacity corrected for indoor air temperature $WB^1 \geq$ Required heat load \times Indoor unit safety factor

Step 3: Select outdoor unit

Determine required total heat load on the outdoor unit

Use the sum of the peak load of each room

Use the system peak load

Provisionally select outdoor unit capacity based on combination ratio limitations

Confirm that the number of indoor units connected to the outdoor unit is within limitation

Correct cooling and heating capacities of the outdoor unit for the following items:
 Outdoor air temperature / Indoor air temperature WB / Combination ratio / Piping length, level difference
 / Piping heat loss / Frost accumulation (for heating capacity only)

Is corrected outdoor unit capacity \geq Required total heat load on outdoor unit?

No

Yes

VRF system selection is complete

Notes:

1. If the indoor design temperature falls between two temperatures listed in the indoor unit's capacity table, calculate the corrected capacity by interpolation. If the indoor unit selection is to be based on total heat load and sensible heat load, select indoor units which satisfy not only the total heat load requirements of each room but also the sensible heat load requirements of each room. As with total heat capacity, the sensible heat capacity of indoor units should be corrected for indoor temperature, interpolating where necessary. For the indoor unit capacity tables, refer to the indoor unit technical manuals.

5.2 Example

The following is a selection example based on total heat load for cooling.

Figure 1-5.1: Room plan

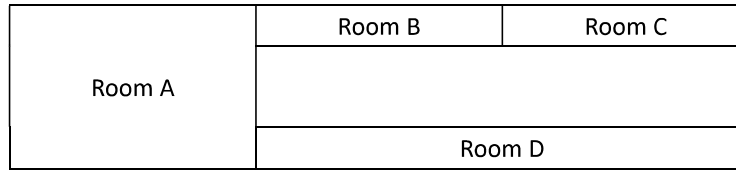

Step 1: Establish design conditions

- Indoor air temperature 25°C DB, 18°C WB; outdoor air temperature 33°C DB.
- Determine peak load of each room and system peak load. As shown in Table 1-5.1, the system peak load is 10.5kW.

Table 1-5.1: Required heat load of each room (kW)

Time	Room A	Room B	Room C	Room D	Total
9:00	2.5	1.6	1.6	1.6	7.3
12:00	3.2	2.4	2.4	2.4	10.4
14:00	3.1	2.4	2.4	2.6	10.5
16:00	3.1	2.3	2.3	2.3	10

- The maximum piping lengths and level differences in this example are as given in Figure 1-5.2.

Figure 1-5.2: System diagram

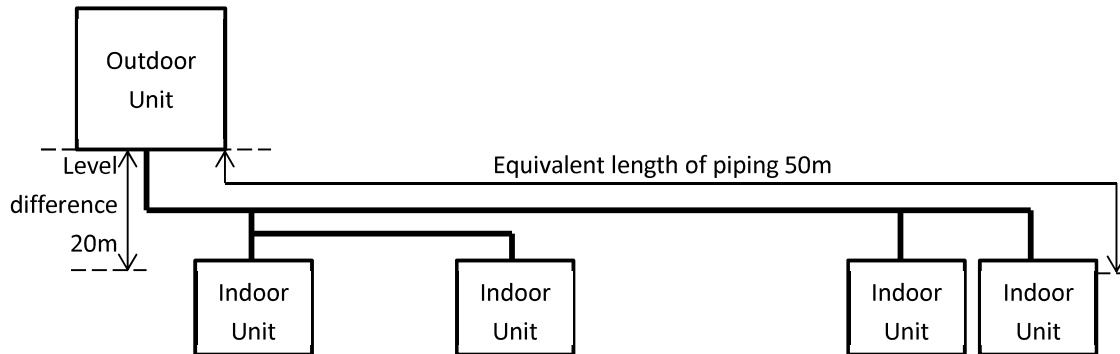

- Indoor unit type for all rooms: Medium Static Pressure Duct (T2).

Step 2: Select indoor units

- In this example, a safety factor is not used (i.e. the safety factor is 1).
- Select indoor unit models using the medium static pressure duct cooling capacity table. Each indoor unit's corrected capacity needs to be greater than or equal to the peak load of the relevant room. The selected indoor units are shown in Table 1-5.3.

Table 1-5.2: Extract from medium static pressure duct (T2) cooling capacity table

Model	Capacity index		Indoor air temperature													
			14°C WB		16°C WB		18°C WB		19°C WB		20°C WB		22°C WB		24°C WB	
			20°C DB		23°C DB		26°C DB		27°C DB		28°C DB		30°C DB		32°C DB	
kBtu/h	kW×10	TC	SHC	TC	SHC	TC	SHC	TC	SHC	TC	SHC	TC	SHC	TC	SHC	
T2	7	22	1.5	1.4	1.8	1.5	2.1	1.6	2.2	1.6	2.3	1.7	2.4	1.5	2.4	1.5
	9	28	1.9	1.7	2.3	1.9	2.6	2.1	2.8	2.1	3.0	2.1	3.1	2.0	3.1	1.9
	12	36	2.5	2.1	2.9	2.3	3.4	2.5	3.6	2.6	3.8	2.7	4.2	2.8	3.9	2.3
	15	45	3.1	2.6	3.7	2.8	4.2	3.1	4.5	3.2	4.8	3.2	4.9	3.1	5.1	2.9
	18	56	3.9	3.0	4.6	3.3	5.3	3.6	5.6	3.7	5.9	3.8	6.2	3.7	6.2	3.4
	24	71	4.9	3.9	5.8	4.3	6.7	4.7	7.1	4.9	7.5	4.8	7.8	4.6	7.8	4.3
	28	80	5.5	4.4	6.6	4.9	7.5	5.3	8.0	5.5	8.4	5.5	8.8	5.2	8.8	4.8
	32	90	6.2	5.3	7.3	5.8	8.4	6.3	9.0	6.4	9.6	6.5	9.9	6.1	9.9	5.7
	40	112	7.7	6.4	9.1	7.1	10.5	7.7	11.2	7.8	11.9	8.1	12.5	7.8	12.5	7.4
	48	140	9.7	7.8	11.3	8.6	13.2	9.6	14.0	9.8	14.8	9.8	15.7	9.7	15.4	8.8

Abbreviations:

TC: Total capacity (kW); SHC: Sensible heat capacity (kW)

Table 1-5.3: Selected indoor units

	Room A	Room B	Room C	Room D
Peak heat load (kW)	3.1	2.4	2.4	2.6
Selected indoor unit	3.6 kW Indoor	2.8 kW Indoor	2.8 kW Indoor	2.8 kW Indoor
Corrected TC (kW)	3.6	2.8	2.8	2.8

Step 3: Select outdoor unit

- Determine the required total heat load from the indoor units to the outdoor unit based on either the sum of the peak loads of each room or the system peak load. In this example, it is determined based on the system peak load. Therefore, the required heat load is 10.5kW.
- Provisionally select an outdoor unit using the sum of the capacity indexes (CIs) of the selected indoor units (as shown in Table 1-5.4), ensuring that the combination ratio is between 50% and 130%. Refer to Table 1-5.5. As the sum of CIs of the indoor units is 120, all outdoor units are potentially suitable except 8kW. Start from the smaller, which is the 10kW unit.

Table 1-5.4: Sum of indoor unit capacity indexes

Model	Capacity Index	No. of units
3.6 kW Indoor	36	1
2.8 kW Indoor	28	3
Sum of CIs	120	

Table 1-5.5: Combinations of Indoor and outdoor units

Outdoor unit capacity kBtu/h	Capacity index	Sum of capacity indexes of connected indoor units (standard indoor units only)
37.5	36	18 to 46.8
47.8	42	21 to 54.6
54.6	48	24 to 62.4
64.8	56	28 to 72.8

- The number of connected indoor units is 4 and the maximum number of connected indoor units on the 10kW outdoor unit is 6, so the number of connected indoor units is within the limitation.
- Calculate the corrected capacity of the outdoor unit:
 - a) The sum of the indoor unit CIs is 120 and the CI of the 10kW outdoor unit is 100, so the combination ratio is $120 / 100 = 120\%$.
 - b) Using the outdoor unit's cooling capacity table, interpolate to obtain the capacity ("B") corrected for outdoor air temperature, indoor air temperature, and combination ratio. Refer to Tables 1-5.6 and 1-5.7.

Table 1-5.6: Extract from Table 2-7.2 BCSF040N0A6-DTM115 cooling capacity

CR	Outdoor air temp. (°C DB)	Indoor air temp. (°C DB / °C WB)	
		25.8 / 18.0	
		TC	PI
		kW	kW
120%	31	10.60	2.02
	33	10.42	2.10
	35	10.26	2.18
110%	31	9.86	2.07
	33	9.86	2.16
	35	9.86	2.21

Table 1-5.7: Cooling capacity calculated by interpolation

CR	Outdoor air temp. (°C DB)	Indoor air temp. (°C DB / °C WB)	
		25.8 / 18.0	
		TC	PI
		kW	kW
120%			
	33	10.42	2.10
	B = 10.44		
110%			
	33	9.86	2.16

- c) Find the correction factor for piping length and level difference ("K1")

Figure 1-5.3: ULTIMA rate of change in cooling capacity

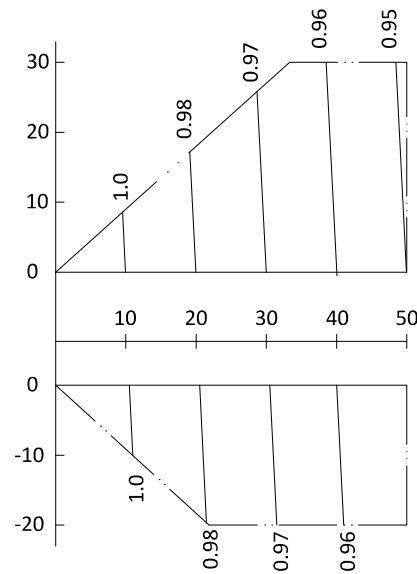

- d) Calculate the corrected capacity of BCSF040N0A6-DTM115 ("C") by using K1:

$$C = B \times K1 = 10.42 \times 0.95 = 9.9 \text{ kW}$$

- The corrected capacity 9.9 kW is lower than required total heat load 10.5kW, so selection is not complete. Step 3 should be repeated from the point where the outdoor unit capacity is provisionally selected.

Repeat Step 3: Select outdoor unit

- Determine the required total heat load from the indoor units to the outdoor unit based on either the sum of the peak loads of each room or the system peak load. In this example, it is determined based on the system peak load. Therefore,

the required heat load is 10.5kW.

- Provisionally select an outdoor unit using the sum of the capacity indexes (CIs) of the selected indoor units (as shown in Table 1-5.5), ensuring that the combination ratio is between 50% and 130%. Refer to Table 1-5.6. As the sum of CIs of the indoor units is 120. For the 10kW unit is not suitable, try to select 12kW unit.
- The number of connected indoor units is 4 and the maximum number of connected indoor units on the 12kW outdoor unit is 7, so the number of connected indoor units is within the limitation.
- Calculate the corrected capacity of the outdoor unit:
 - a) The sum of the indoor unit CIs is 120 and the CI of the 12kW outdoor unit is 120, so the combination ratio is $120 / 120 = 100\%$.
 - b) Using the outdoor unit's cooling capacity table, interpolate to obtain the capacity ("B") corrected for outdoor air temperature, indoor air temperature, and combination ratio. Refer to Tables 1-5.8 and 1-5.9.

Table 1-5.8: Extract from Table 2-7.3 BCSF050N0A7-DTM140 cooling capacity

CR	Outdoor air temp. (°C DB)	Indoor air temp. (°C DB / °C WB)	
		25.8 / 18.0	
		TC	PI
		kW	kW
100%	31	11.84	3.09
	33	11.84	3.25
	35	11.84	3.31
90%	31	10.15	1.81
	33	10.15	1.93
	35	10.15	2.07

Table 1-5.9: Cooling capacity calculated by interpolation

CR	Outdoor air temp. (°C DB)	Indoor air temp. (°C DB / °C WB)	
		25.8 / 18.0	
		TC	PI
		kW	kW
100%	33	11.84	3.25
	B = 11.2		
90%	33	10.15	1.93

- c) Find the correction factor for piping length and level difference ("K1")

Figure 1-5.4: ULTIMA rate of change in cooling capacity

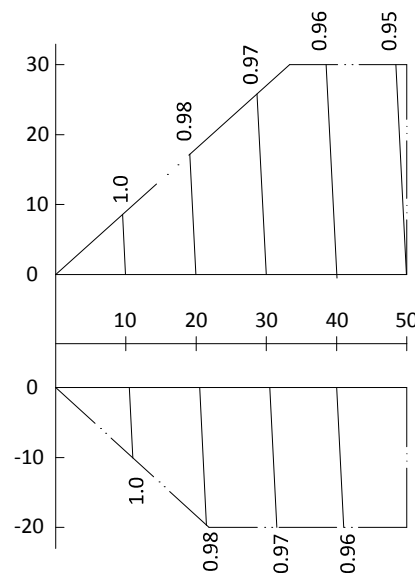

- d) Calculate the corrected capacity of BCSF050N0A7-DTM140 ("C") by using K1:

$$C = B \times K1 = 11.84 \times 0.95 = 11.2W$$

- The corrected capacity 11.2 kW is larger than required total heat load 10.5kW, so selection is complete.

Part 2

Outdoor Unit

Engineering Data

1 Specifications	14
2 Dimensions	16
3 Installation Space Requirements	17
4 Piping Diagrams	18
5 Wiring Diagrams.....	20
6 Electrical Characteristics.....	22
7 Functional Components and Safety Devices	23
8 Capacity Tables.....	24
9 Operating Limits.....	50
10 Sound Levels	51
11 Accessories.....	52

1 Specifications

BCSF030N0A4-DTM090 / BCSF040N0A6-DTM115 / BCSF050N0A7-DTM140

Table 2-1.1: 30/40/50 model specifications

Model name			BCSF030N0A4-DTM090	BCSF040N0A6-DTM115	BCSF050N0A7-DTM140
Power supply			1 phase, 220-240V, 50/60Hz		
Cooling ¹	Capacity	kBtu/h	30.7	37.5	47.8
		kW	8	10	12
	Power input	kW	1.94	2.35	3.18
	EER			4.12	4.26
Connectable indoor unit	Total capacity		45-130% of outdoor unit capacity		
	Quantity		1~4	1~5	1~6
Compressors	Type		DC inverter	DC inverter	DC inverter
	Quantity		1	1	1
	Oil type		FV50S	FV50S	FV50S
Fan	Motor type		DC	DC	DC
	Quantity		1	1	1
	Motor input	W	112	112	112
	Motor output	W	90	90	90
Air flow rate		m ³ /h	3400	3400	3400
Refrigerant	Type		R410A		
	Factory charge	kg (lbs.)	1.4 (3.1)	1.4 (3.1)	1.4 (3.1)
Pipe connections ²	Liquid pipe	mm (in.)	Φ9.5 (Φ3/8)	Φ9.5 (Φ3/8)	Φ9.5 (Φ3/8)
	Gas pipe	mm (in.)	Φ15.9 (Φ5/8)	Φ15.9 (Φ5/8)	Φ15.9 (Φ5/8)
Sound pressure level ³		dB(A)	54	54	54
Net dimensions (W×H×D)		mm	973×862×355	973×862×355	973×862×355
		in.	38-5/16×33-15/16×13-31/32	38-5/16×33-15/16×13-31/32	38-5/16×33-15/16×13-31/32
Packed dimensions (W×H×D)		mm	1025×910×410	1025×910×410	1025×910×410
		in.	40-23/64×35-53/64×16-9/64	40-23/64×35-53/64×16-9/64	40-23/64×35-53/64×16-9/64
Net weight		kg (lbs.)	58 (128)	58 (128)	58 (128)
Gross weight		kg (lbs.)	63 (139)	63 (139)	63 (139)
Operating temperature range		°C (°F)	-5 to 48 (23 to 118.4)		

Notes:

- Indoor air temperature 27°C (80.6°F) DB, 19°C (66.2°F) WB; outdoor air temperature 35°C (95.0°F) DB; equivalent refrigerant piping length 5.0m (16.4ft.) with zero level difference.
- Diameters given are those of the unit's stop valve.
- Sound pressure level is measured at a position 1m (3.28ft.) in front of the unit and 1.3m (4.26ft.) above the floor in a semi-anechoic chamber.
- The above data may be changed without notice for future improvement on quality and performance.

Conversion Formulae:
 kBtu/h = kW × 3.412;
 in.W.G. = Pa × 0.004;
 lbs. = kg × 2.2;
 in. = mm / 25.4

BCSF060N0A8-DTM160 / BCSF070N0A9-DTM190

Table 2-1.2: 60/70 model specification

Model name			BCSF060N0A8-DTM160	BCSF070N0A9-DTM190
Power supply			1 phase, 220-240V, 50/60Hz	
Cooling ¹	Capacity	kBtu/h	54.6	64.8
		kW	14	16
	Power input	kW	3.54	3.86
	EER		3.95	4.15
Connectable indoor unit	Total capacity		45-130% of outdoor unit capacity	
	Quantity		1~8	1~9
Compressors	Type		DC inverter	DC inverter
	Quantity		1	1
	Oil type		FV50S	FV50S
Fan	Motor type		DC	DC
	Quantity		1	1
	Motor input	W	250	250
	Motor output	W	200	200
Air flow rate		m ³ /h	5100	5100
Refrigerant	Type		R410A	
	Factory charge	kg (lbs.)	2.6 (5.7)	2.6 (5.7)
Pipe connections ²	Liquid pipe	mm (in.)	Φ9.5 (Φ3/8)	Φ9.5 (Φ3/8)
	Gas pipe	mm (in.)	Φ15.9 (Φ5/8)	Φ15.9 (Φ5/8)
Sound pressure level ³		dB(A)	55	55
Net dimensions (W×H×D)	mm		1040x865x523	1040x865x523
	in.		40-15/16×34-1/16×20-19/32	40-15/16×34-1/16×20-19/32
Packed dimensions (W×H×D)	mm		1120x980x560	1120x980x560
	in.		44-3/32×38-37/64×22-3/64	44-3/32×38-37/64×22-3/64
Net weight		kg (lbs.)	85 (187)	85 (187)
Gross weight		kg (lbs.)	99.5 (202)	99.5 (202)
Operating temperature range		°C (°F)	-5 to 48 (23 to 118.4)	

Notes:

- Indoor air temperature 27°C (80.6°F) DB, 19°C (66.2°F) WB; outdoor air temperature 35°C (95.0°F) DB; equivalent refrigerant piping length 5.0m (16.4ft.) with zero level difference.
- Diameters given are those of the unit's stop valve.
- Sound pressure level is measured at a position 1m (3.28ft.) in front of the unit and 1.3m (4.26ft.) above the floor in a semi-anechoic chamber.
- The above data may be changed without notice for future improvement on quality and performance.

Conversion Formulae:
 kBtu/h = kW × 3.412;
 in.W.G. = Pa × 0.004;
 lbs. = kg × 2.2;
 in. = mm / 25.4

2 Dimensions

BCSF030N0A4-DTM090 / BCSF040N0A6-DTM115 / BCSF050N0A7-DTM140

Figure 2-2.1: 30/40/50 model front view dimensions

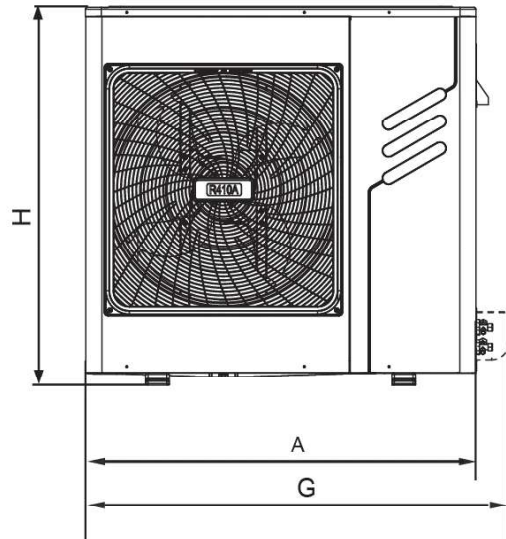
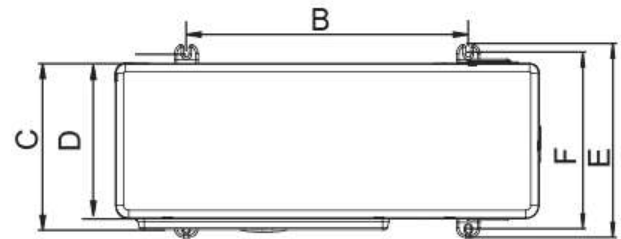

Figure 2-2.2: 30/40/50 model top view dimensions



BCSF060N0A8-DTM160 / BCSF070N0A9-DTM190

Figure 2-2.3: 60/70 model front view dimensions

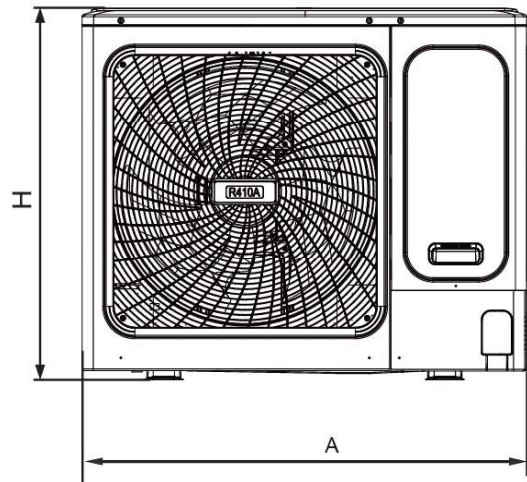

Figure 2-2.4: 60/70 model front top dimensions

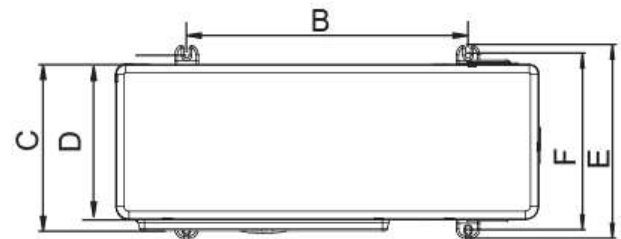

Table 2-2.1: Outdoor unit dimensions (unit: mm)

Model	A	B	C	D	E	F	G	H
30/40/50	895	590	346	302	355	333	973	862
60/70	1040	656	452	410	523	463	--	865

3 Installation Space Requirements

Figure 2-3.1: Single unit installation top view (unit: mm)

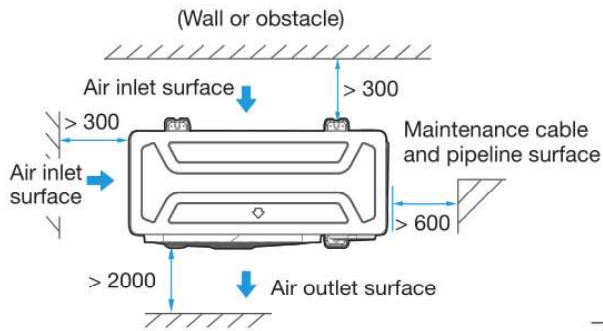

Figure 2-3.2: Single unit installation side view (unit: mm)

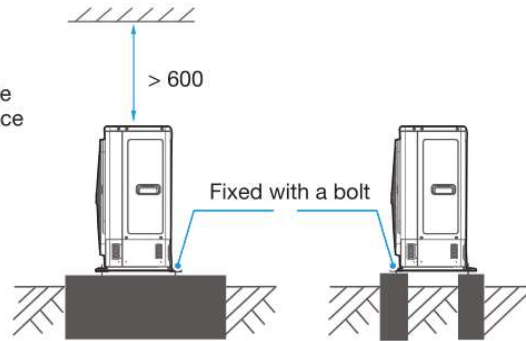

Figure 2-3.3: Multiple unit installation top view (unit: mm)

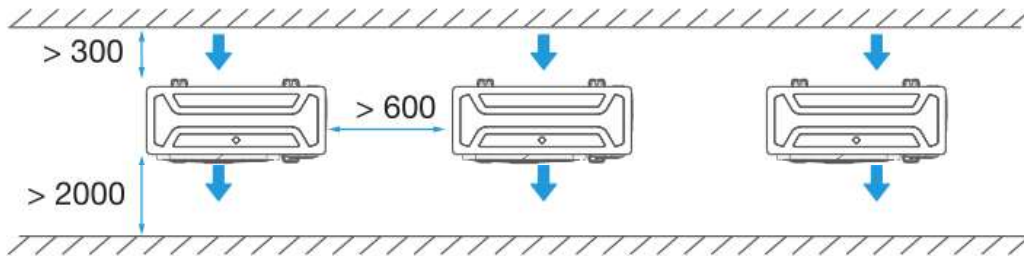
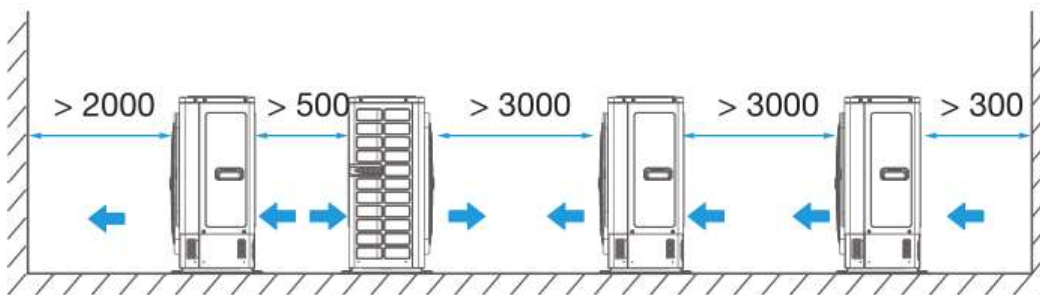

Figure 2-3.4: Multiple unit installation side view (unit: mm)



4 Piping Diagrams

BCSF030N0A4-DTM090 / BCSF040N0A6-DTM115 / BCSF050N0A7-DTM140

Figure 2-4.1: 30/40/50 model piping diagram

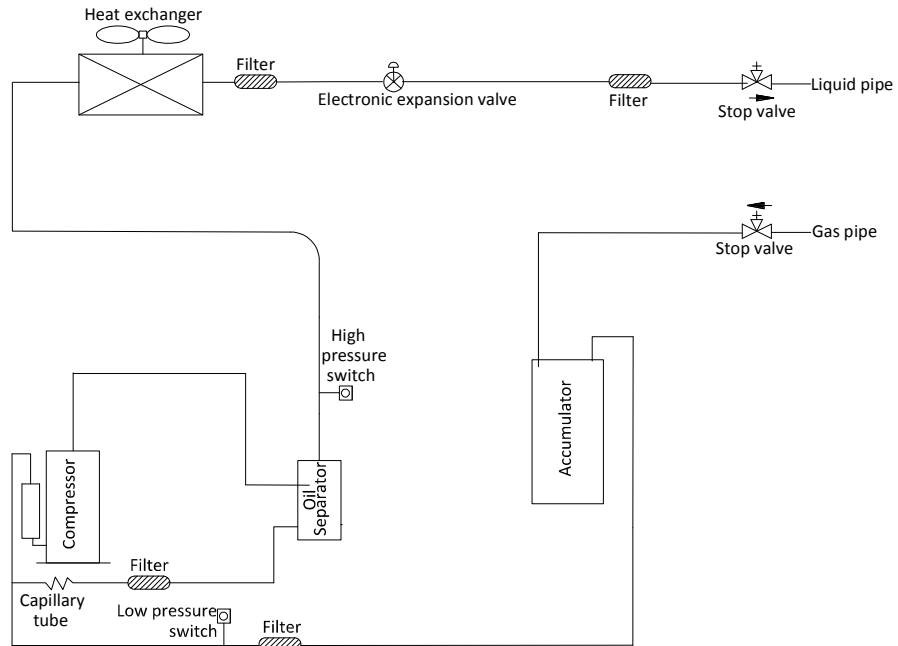

BCSF060N0A8-DTM160 / BCSF070N0A9-DTM190

Figure 2-4.2: 60/70 model piping diagram

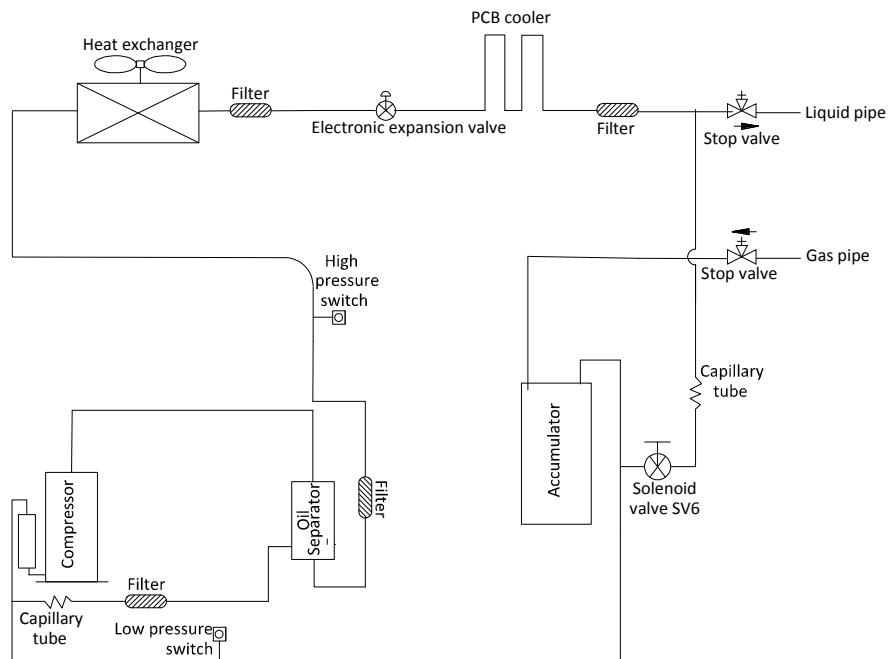

Key components:

1. **Oil separator:**
Separates oil from gas refrigerant pumped out of the compressor and quickly returns it to the compressor. Separation efficiency is up to 99%.
2. **Accumulator:**
Stores liquid refrigerant and oil to protect compressor from liquid hammering.
3. **Electronic expansion valve (EXV):**
Controls refrigerant flow and reduces refrigerant pressure.
4. **Solenoid valve SV6:**
Protects the compressor. If compressor discharge temperature rises above 100°C, SV6 opens and sprays a small amount of liquid refrigerant to cool the compressor. SV6 closes again once the discharge temperature has fallen below 90°C.
5. **High and low pressure switches:**
Regulate system pressure. When system pressure rises above the upper limit or falls below the lower limit, the high or low pressure switches turn off, stopping the compressor. After 10 minutes, the compressor restarts.

5 Wiring Diagrams

BCSF030N0A4-DTM090 / BCSF040N0A6-DTM115 / BCSF050N0A7-DTM140

Figure 2-5.1: 30/40/50 model wiring diagram

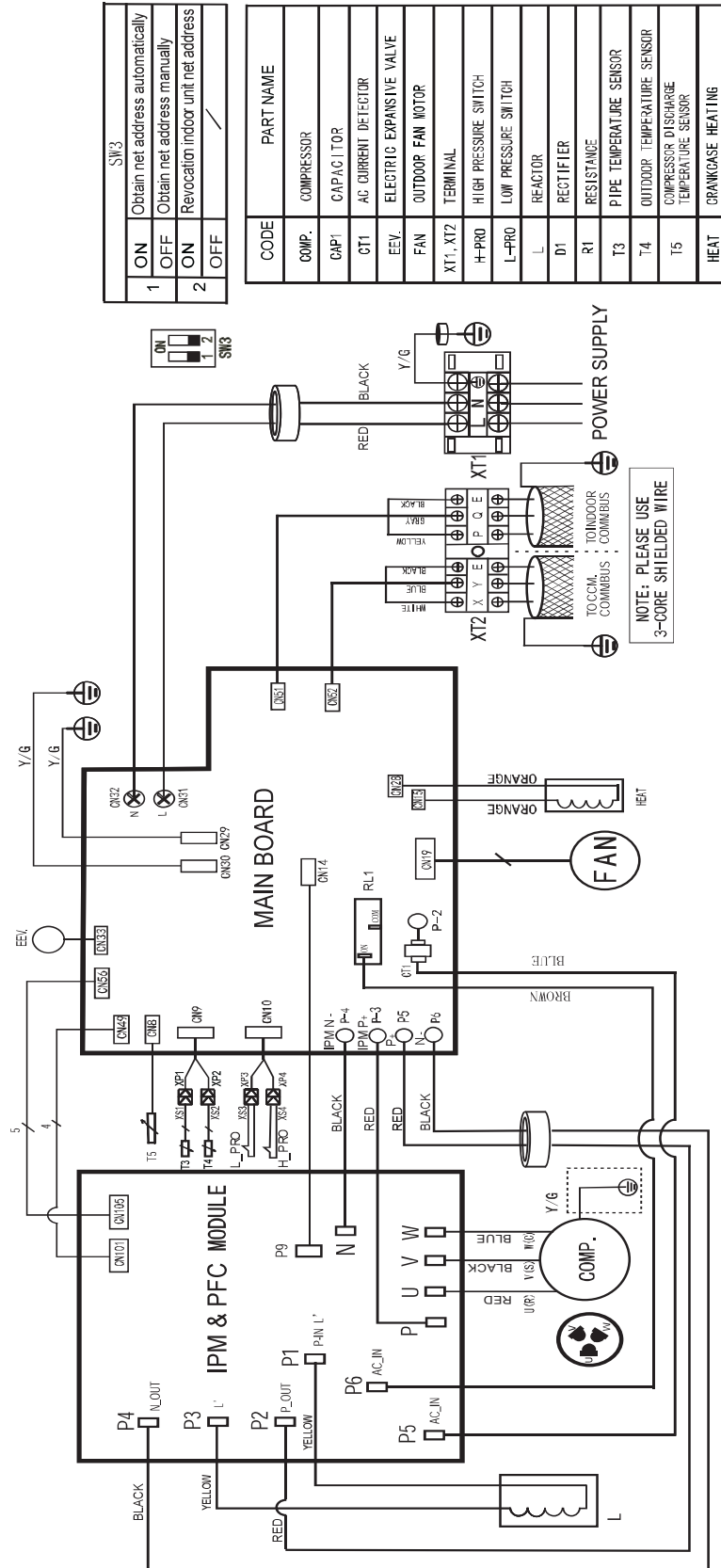

BCSF060N0A8-DTM160 / BCSF070N0A9-DTM190

Figure 2-5.2: 60/70 model wiring diagram

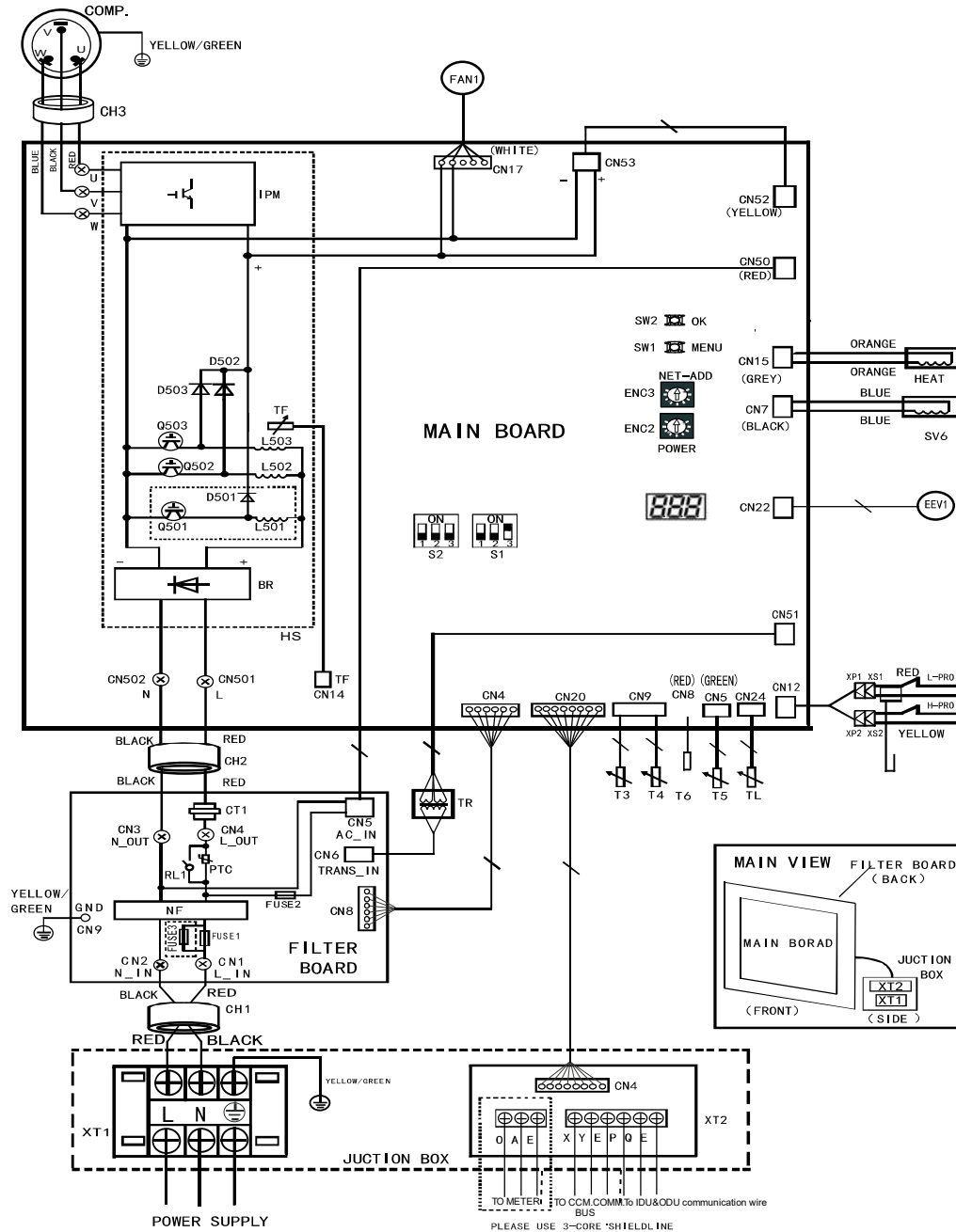

AND MAKE SURE THAT THE SHIELD

CODE	PRAT NAME	CODE	PART NAME
BR	RECTIFIER	IPM	POWER MODULE
CH1-CH4	MAGNETIC RINGS	NF	FILTER
COMP.	COMPRESSOR	Q501-Q503	IGBT
CT1	AC CURRENT TRANSFORMER	RL1	RELAY
D501-D503	FAST RECOVERY DIODE	PTC	THERMAL RESISTOR
EEV1	ELECTRIC EXPANSIVE VALVE	SV6	ELECTROMAGNETIC VALVE
FAN1	OUTDOOR FAN MOTOR	T3	PIPE TEMPERATURE SENSOR
L501-L503	PFC INDUCTANCE	T4	OUTDOOR TEMPERATURE SENSOR
FUSE1-FUSE3	FUSES	T5	COMP. DISCHARGE TEMPERATURE SENSOR

CODE	PRAT NAME	CODE	PART NAME
HEAT1	GRANKCASE ELECTIC HEATING	T6	SHORT CIRCUIT SENSOR
HS	RADIATOR	TF	RADIATOR TEMPERATURE SENSOR
H-PRO	HIGH PRESSURE SWITCH	TL	RADIATING PIPE TEMPERATURE SENSOR
L-PRO	LOW PRESSURE SWITCH	TR	TRANSFORMER
XP1-XP2	3-WAY TERMINAL	XT1	3-WAY TERMINAL
XS1-XS2	3-WAY TERMINAL	XT2	COMMUNICATION SWITCHING BOARD

6 Electrical Characteristics

Table 2-6.1: Outdoor unit electrical characteristics

Capacity	Power supply ¹						Compressors		Outdoor fan motors		
	Hz	Volts	Min. volts	Max. volts	MCA ²	TOCA ³	MFA ⁴	MSC ⁵	RLA ⁶	Rated motor output (kW)	FLA
BCSF030N0A4-DTM090	50/60	220-240	187	253	23.0	25.0	30		9.7	0.09	1.0
BCSF040N0A6-DTM115	50/60	220-240	187	253	23.0	25.0	30	-	9.7	0.09	1.0
BCSF050N0A7-DTM140	50/60	220-240	187	253	23.0	25.0	30	-	9.7	0.09	1.0
BCSF060N0A8-DTM160	50/60	220-240	187	253	33.0	34.0	40	-	14.8	0.20	1.7
BCSF070N0A9-DTM190	50/60	220-240	187	253	33.0	34.0	40	-	14.8	0.20	1.7

Abbreviations:

MCA:	Minimum Circuit Amps
TOCA:	Total Over-current Amps
MFA:	Maximum Fuse Amps
MSC:	Maximum Starting Current (A)
RLA:	Rated Load Amps
FLA:	Full Load Amps

Notes:

1. Units are suitable for use on electrical systems where voltage supplied to unit terminals is not below or above listed range limits. Maximum allowable voltage variation between phases is 2%.
2. Select wire size based on the value of MCA.
3. TOCA indicates the total overcurrent amps value of each OC set.
4. MFA is used to select overcurrent circuit breakers and residual-current circuit breakers.
5. MSC indicates the maximum current on compressor start-up in amps.
6. RLA is based on the following conditions: indoor temperature 27°C DB, 19°C WB; outdoor temperature 35°C DB.

7 Functional Components and Safety Devices

Table 2-7.1: BCSF030, 040, 050 functional components and safety devices

Item		BCSF030N0A4-DTM090	BCSF040N0A6-DTM115	BCSF050N0A7-DTM140
Compressor	Discharge temperature switch	/		
	Compressor top temperature sensors	90°C = 5kΩ ± 3%		
	Crankcase heater	25W × 1		
Inverter module	Inverter module temperature sensor	/		
Fan motor	Safety thermostat	On	115°C	
		Off	-	
System	High pressure switch	Off: 4.4 (±0.1) MPa / On: 3.2 (±0.1) MPa		
	Low pressure switch	Off: 0.05 (±0.05) MPa / On: 0.15 (±0.05) MPa		
	High pressure sensor	/		
	Heat exchanger temperature sensor	25°C = 10kΩ		
	Outdoor ambient temperature sensor	25°C = 10kΩ		

Table 2-7.2: BCSF060, 070 functional components and safety devices

Item		BCSF060N0A8-DTM160	BCSF070N0A9-DTM190
Compressor	Discharge temperature switch	/	
	Compressor top temperature sensors	90°C = 5kΩ ± 3%	
	Crankcase heater	25W × 1	
Inverter module	Inverter module temperature sensor	25°C = 10kΩ	
Fan motor	Safety thermostat	On	115°C
		Off	-
System	High pressure switch	Off: 4.4 (±0.1) MPa / On: 3.2 (±0.1) MPa	
	Low pressure switch	Off: 0.05 (±0.05) MPa / On: 0.15 (±0.05) MPa	
	High pressure sensor	/	
	Heat exchanger temperature sensor	25°C = 10kΩ	
	Outdoor ambient temperature sensor	25°C = 10kΩ	

8 Capacity Tables

8.1 Cooling Capacity Tables

Table 2-8.1: BCSF030N0A4-DTM090 cooling capacity

CR	Outdoor air temp. (°C DB)	Indoor air temp. (°C DB / °C WB)													
		20.8 / 14.0		23.3 / 16.0		25.8 / 18.0		27.0 / 19.0		28.2 / 20.0		30.7 / 22.0		32.0 / 24.0	
		TC	PI	TC	PI	TC	PI	TC	PI	TC	PI	TC	PI	TC	PI
130%	-5	6.24	1.30	7.28	1.33	8.84	1.50	10.40	1.66	10.71	1.83	10.92	2.00	11.23	2.33
	-2	6.24	1.33	7.28	1.36	8.84	1.53	10.40	1.70	10.71	1.87	10.92	2.04	11.23	2.38
	0	6.24	1.33	7.28	1.36	8.84	1.53	10.40	1.70	10.71	1.87	10.92	2.04	11.23	2.38
	2	6.24	1.33	7.28	1.36	8.84	1.53	10.40	1.70	10.71	1.87	10.92	2.04	11.23	2.38
	4	6.24	1.36	7.28	1.39	8.84	1.57	10.40	1.74	10.71	1.91	10.92	2.09	11.23	2.44
	6	6.24	1.36	7.28	1.39	8.84	1.57	10.40	1.74	10.71	1.91	10.92	2.09	11.23	2.44
	8	6.24	1.36	7.28	1.39	8.84	1.57	10.40	1.74	10.71	1.91	10.92	2.09	11.23	2.44
	10	6.24	1.39	7.28	1.42	8.84	1.60	10.40	1.78	10.71	1.96	10.92	2.13	11.23	2.49
	12	6.24	1.42	7.28	1.45	8.84	1.63	10.40	1.82	10.71	2.00	10.92	2.18	11.23	2.54
	14	6.24	1.45	7.28	1.48	8.84	1.67	10.40	1.85	10.71	2.04	10.92	2.22	11.23	2.60
	16	6.24	1.50	7.28	1.54	8.84	1.74	10.40	1.93	10.71	2.12	10.92	2.32	11.23	2.70
	18	6.24	1.56	7.28	1.60	8.84	1.80	10.40	2.00	10.71	2.21	10.92	2.41	11.23	2.81
	20	6.24	1.71	7.28	1.76	8.84	1.97	10.40	2.19	10.71	2.41	10.92	2.63	11.23	3.07
	21	6.24	1.80	7.28	1.85	8.84	2.08	10.40	2.31	10.71	2.54	10.92	2.77	11.23	3.23
	23	6.24	1.89	7.28	1.94	8.84	2.18	10.40	2.42	10.71	2.66	10.92	2.91	11.23	3.29
	25	6.24	1.98	7.28	2.03	8.84	2.28	10.40	2.53	10.71	2.79	10.92	3.04	11.23	3.30
	27	6.24	2.07	7.28	2.12	8.84	2.38	10.40	2.65	10.71	2.91	10.92	3.18	11.23	3.41
	29	6.24	2.12	7.28	2.18	8.84	2.45	10.40	2.72	10.71	3.00	10.92	3.27	11.23	3.43
	31	6.24	2.15	7.28	2.21	8.84	2.49	10.40	2.76	10.71	3.04	10.92	3.18	11.23	3.48
	33	6.24	2.18	7.28	2.35	8.84	2.55	10.40	2.80	10.71	3.08	10.92	3.11	11.23	3.41
35	6.24	2.33	7.28	2.45	8.84	2.65	10.40	2.91	10.71	3.21	10.92	3.50	11.23	3.54	
37	4.99	2.42	5.82	2.55	7.07	2.75	8.32	2.97	8.33	3.32	8.36	3.76	8.76	3.81	
39	4.68	2.51	5.46	2.64	6.63	2.85	7.80	3.05	7.81	3.43	8.04	3.91	8.21	3.98	
41	4.37	2.60	5.10	2.73	6.19	2.95	6.28	3.15	6.53	3.62	6.59	4.07	6.66	4.21	
43	4.06	2.70	4.73	2.82	5.75	3.05	6.06	3.32	6.43	3.87	6.39	4.17	6.61	4.25	
45	3.74	2.81	4.37	2.93	5.30	3.15	5.74	3.65	5.94	4.14	6.27	4.32	6.57	4.38	
48	3.43	2.92	4.00	3.05	4.86	3.25	5.12	3.87	5.73	4.31	5.75	4.51	6.02	4.73	
120%	-5	5.76	1.17	7.01	1.20	8.16	1.35	9.60	1.49	9.62	1.64	9.64	1.79	10.11	2.09
	-2	5.76	1.19	7.01	1.22	8.16	1.38	9.60	1.53	9.62	1.68	9.64	1.83	10.11	2.14
	0	5.76	1.19	7.01	1.22	8.16	1.38	9.60	1.53	9.62	1.68	9.64	1.83	10.11	2.14
	2	5.76	1.19	7.01	1.22	8.16	1.38	9.60	1.53	9.62	1.68	9.64	1.83	10.11	2.14
	4	5.76	1.22	7.01	1.25	8.16	1.41	9.60	1.56	9.62	1.72	9.64	1.88	10.11	2.19
	6	5.76	1.22	7.01	1.25	8.16	1.41	9.60	1.56	9.62	1.72	9.64	1.88	10.11	2.19
	8	5.76	1.22	7.01	1.25	8.16	1.41	9.60	1.56	9.62	1.72	9.64	1.88	10.11	2.19
	10	5.76	1.25	7.01	1.28	8.16	1.44	9.60	1.60	9.62	1.76	9.64	1.92	10.11	2.24
	12	5.76	1.27	7.01	1.30	8.16	1.47	9.60	1.63	9.62	1.79	9.64	1.96	10.11	2.28
	14	5.76	1.30	7.01	1.33	8.16	1.50	9.60	1.66	9.62	1.83	9.64	2.00	10.11	2.33
	16	5.76	1.35	7.01	1.39	8.16	1.56	9.60	1.73	9.62	1.91	9.64	2.08	10.11	2.43
	18	5.76	1.40	7.01	1.44	8.16	1.62	9.60	1.80	9.62	1.98	9.64	2.16	10.11	2.52
	20	5.76	1.54	7.01	1.58	8.16	1.77	9.60	1.97	9.62	2.17	9.64	2.36	10.11	2.76
	21	5.76	1.62	7.01	1.66	8.16	1.87	9.60	2.07	9.62	2.28	9.64	2.49	10.11	2.90
	23	5.76	1.70	7.01	1.74	8.16	1.96	9.60	2.17	9.62	2.39	9.64	2.61	10.11	3.04
	25	5.76	1.78	7.01	1.82	8.16	2.05	9.60	2.28	9.62	2.50	9.64	2.73	10.11	3.19
	27	5.76	1.93	7.01	1.98	8.16	2.23	9.60	2.48	9.62	2.73	9.64	2.98	10.11	3.47
	29	5.76	2.07	7.01	2.12	8.16	2.38	9.60	2.65	9.62	2.91	9.64	3.18	10.11	3.71
	31	5.76	2.12	7.01	2.17	8.16	2.45	9.60	2.72	9.62	2.99	9.64	3.13	10.11	3.80
	33	5.76	2.17	7.01	2.23	8.16	2.51	9.60	2.79	9.62	3.06	9.64	3.09	10.11	3.77
35	5.76	2.21	7.01	2.26	8.16	2.55	9.60	2.83	9.62	2.97	9.64	3.14	10.11	3.65	
37	5.41	2.20	6.59	2.26	7.67	2.54	9.02	2.82	9.04	2.97	9.07	3.13	9.50	3.59	
39	5.18	2.50	6.31	2.56	7.34	2.88	8.64	3.20	8.66	3.36	8.68	3.55	9.10	3.93	
41	4.90	2.65	5.96	2.72	6.94	3.06	8.16	3.40	8.17	3.57	8.20	3.77	8.59	3.99	
43	4.61	2.76	5.61	2.83	6.53	3.18	7.68	3.54	7.69	3.72	7.72	3.93	8.09	4.05	
45	4.32	2.87	5.26	2.94	6.12	3.31	7.20	3.68	7.21	3.86	7.23	4.09	7.58	4.16	
48	4.03	3.00	4.91	3.08	5.71	3.47	6.72	3.85	6.73	4.16	6.75	4.20	7.07	4.25	

Abbreviations:

CR: Combination ratio

TC: Total capacity (kW)

PI: Power input (compressor + outdoor fan motor) (kW)

Notes:

1. Shaded cells indicate rating condition.

Table continued on next page ...

Table 2-8.1: BCSF030N0A4-DTM090 cooling capacity (continued)

CR	Outdoor air temp. (°C DB)	Indoor air temp. (°C DB / °C WB)													
		20.8 / 14.0		23.3 / 16.0		25.8 / 18.0		27.0 / 19.0		28.2 / 20.0		30.7 / 22.0		32.0 / 24.0	
		TC kW	PI kW	TC kW	PI kW	TC kW	PI kW	TC kW	PI kW	TC kW	PI kW	TC kW	PI kW	TC kW	PI kW
110%	-5	5.28	1.05	6.42	1.08	7.48	1.21	8.80	1.35	8.82	1.48	8.84	1.61	9.26	1.88
	-2	5.28	1.07	6.42	1.10	7.48	1.23	8.80	1.37	8.82	1.51	8.84	1.65	9.26	1.92
	0	5.28	1.09	6.42	1.12	7.48	1.26	8.80	1.40	8.82	1.54	8.84	1.68	9.26	1.96
	2	5.28	1.11	6.42	1.14	7.48	1.28	8.80	1.42	8.82	1.57	8.84	1.71	9.26	1.99
	4	5.28	1.13	6.42	1.16	7.48	1.31	8.80	1.45	8.82	1.60	8.84	1.74	9.26	2.03
	6	5.28	1.15	6.42	1.18	7.48	1.33	8.80	1.48	8.82	1.63	8.84	1.77	9.26	2.07
	8	5.28	1.17	6.42	1.20	7.48	1.35	8.80	1.50	8.82	1.65	8.84	1.80	9.26	2.11
	10	5.28	1.19	6.42	1.22	7.48	1.38	8.80	1.53	8.82	1.68	8.84	1.84	9.26	2.14
	12	5.28	1.21	6.42	1.25	7.48	1.40	8.80	1.56	8.82	1.71	8.84	1.87	9.26	2.18
	14	5.28	1.23	6.42	1.27	7.48	1.42	8.80	1.58	8.82	1.74	8.84	1.90	9.26	2.22
	16	5.28	1.26	6.42	1.29	7.48	1.45	8.80	1.61	8.82	1.77	8.84	1.93	9.26	2.25
	18	5.28	1.30	6.42	1.33	7.48	1.50	8.80	1.66	8.82	1.83	8.84	1.99	9.26	2.33
	20	5.28	1.40	6.42	1.44	7.48	1.61	8.80	1.79	8.82	1.97	8.84	2.15	9.26	2.51
	21	5.28	1.46	6.42	1.50	7.48	1.69	8.80	1.87	8.82	2.06	8.84	2.25	9.26	2.62
	23	5.28	1.52	6.42	1.56	7.48	1.76	8.80	1.95	8.82	2.15	8.84	2.34	9.26	2.73
	25	5.28	1.58	6.42	1.63	7.48	1.83	8.80	2.03	8.82	2.23	8.84	2.44	9.26	2.84
	27	5.28	1.63	6.42	1.67	7.48	1.88	8.80	2.08	8.82	2.29	8.84	2.50	9.26	2.92
	29	5.28	1.67	6.42	1.71	7.48	1.92	8.80	2.14	8.82	2.35	8.84	2.56	9.26	2.99
	31	5.28	1.75	6.42	1.79	7.48	2.02	8.80	2.24	8.82	2.47	8.84	2.58	9.26	3.14
	33	5.28	1.79	6.42	1.84	7.48	2.07	8.80	2.30	8.82	2.53	8.84	2.55	9.26	3.10
	35	5.28	1.87	6.42	1.92	7.48	2.16	8.80	2.40	8.82	2.52	8.84	2.66	9.26	3.09
	37	4.96	1.87	6.04	1.91	7.03	2.15	8.27	2.39	8.29	2.51	8.31	2.66	8.71	3.04
	39	4.75	2.11	5.78	2.17	6.73	2.44	7.92	2.71	7.93	2.85	7.96	3.01	8.34	3.37
	41	4.49	2.25	5.46	2.30	6.36	2.59	7.48	2.88	7.49	3.02	7.51	3.20	7.87	3.46
43	4.22	2.34	5.14	2.40	5.98	2.70	7.04	3.00	7.05	3.15	7.07	3.33	7.41	3.52	
45	3.96	2.43	4.82	2.49	5.61	2.81	6.60	3.12	6.61	3.27	6.63	3.46	6.95	3.61	
48	3.70	2.54	4.50	2.61	5.24	2.94	6.16	3.26	6.17	3.52	6.19	3.56	6.49	3.67	
100%	-5	4.80	0.92	5.84	0.95	6.80	1.07	8.00	1.18	8.01	1.30	8.04	1.42	8.42	1.66
	-2	4.80	0.94	5.84	0.96	6.80	1.08	8.00	1.20	8.01	1.32	8.04	1.44	8.42	1.68
	0	4.80	0.95	5.84	0.98	6.80	1.10	8.00	1.22	8.01	1.34	8.04	1.47	8.42	1.71
	2	4.80	0.97	5.84	0.99	6.80	1.12	8.00	1.24	8.01	1.37	8.04	1.49	8.42	1.74
	4	4.80	0.98	5.84	1.01	6.80	1.13	8.00	1.26	8.01	1.39	8.04	1.51	8.42	1.77
	6	4.80	1.00	5.84	1.02	6.80	1.15	8.00	1.28	8.01	1.41	8.04	1.54	8.42	1.79
	8	4.80	1.01	5.84	1.04	6.80	1.17	8.00	1.30	8.01	1.43	8.04	1.56	8.42	1.82
	10	4.80	1.03	5.84	1.06	6.80	1.19	8.00	1.32	8.01	1.45	8.04	1.58	8.42	1.85
	12	4.80	1.04	5.84	1.07	6.80	1.20	8.00	1.34	8.01	1.47	8.04	1.61	8.42	1.87
	14	4.80	1.06	5.84	1.09	6.80	1.22	8.00	1.36	8.01	1.49	8.04	1.63	8.42	1.90
	16	4.80	1.07	5.84	1.10	6.80	1.24	8.00	1.38	8.01	1.52	8.04	1.65	8.42	1.93
	18	4.80	1.09	5.84	1.12	6.80	1.26	8.00	1.40	8.01	1.54	8.04	1.68	8.42	1.96
	20	4.80	1.10	5.84	1.13	6.80	1.27	8.00	1.42	8.01	1.56	8.04	1.70	8.42	1.98
	21	4.80	1.12	5.84	1.15	6.80	1.29	8.00	1.44	8.01	1.58	8.04	1.72	8.42	2.01
	23	4.80	1.13	5.84	1.16	6.80	1.31	8.00	1.46	8.01	1.60	8.04	1.75	8.42	2.04
	25	4.80	1.15	5.84	1.18	6.80	1.33	8.00	1.47	8.01	1.62	8.04	1.77	8.42	2.06
	27	4.80	1.17	5.84	1.20	6.80	1.34	8.00	1.49	8.01	1.64	8.04	1.79	8.42	2.09
	29	4.80	1.20	5.84	1.23	6.80	1.38	8.00	1.53	8.01	1.69	8.04	1.84	8.42	2.15
	31	4.80	1.26	5.84	1.29	6.80	1.45	8.00	1.61	8.01	1.77	8.04	1.85	8.42	2.25
	33	4.80	1.38	5.84	1.41	6.80	1.59	8.00	1.77	8.01	1.94	8.04	1.96	8.42	2.39
	35	4.80	1.51	5.84	1.55	6.80	1.75	8.00	1.94	8.01	2.04	8.04	2.15	8.42	2.50
	37	4.51	1.51	5.49	1.55	6.39	1.74	7.52	1.94	7.53	2.03	7.55	2.15	7.92	2.46
	39	4.32	1.71	5.26	1.75	6.12	1.97	7.20	2.19	7.21	2.30	7.23	2.43	7.58	2.78
	41	4.08	1.82	4.96	1.86	5.78	2.10	6.80	2.33	6.81	2.44	6.83	2.58	7.16	2.89
43	3.84	1.89	4.67	1.94	5.44	2.18	6.40	2.43	6.41	2.55	6.43	2.69	6.74	2.94	
45	3.60	1.97	4.38	2.02	5.10	2.27	6.00	2.52	6.01	2.65	6.03	2.80	6.32	3.03	
48	3.36	2.06	4.09	2.11	4.76	2.37	5.60	2.64	5.61	2.85	5.63	2.93	5.90	3.13	

Abbreviations:

CR: Combination ratio

TC: Total capacity (kW)

PI: Power input (compressor + outdoor fan motor) (kW)

Notes:

1. Shaded cells indicate rating condition.

Table continued on next page ...

Table 2-8.1: BCSF030N0A4-DTM090 cooling capacity (continued)

CR	Outdoor air temp. (°C DB)	Indoor air temp. (°C DB / °C WB)													
		20.8 / 14.0		23.3 / 16.0		25.8 / 18.0		27.0 / 19.0		28.2 / 20.0		30.7 / 22.0		32.0 / 24.0	
		TC kW	PI kW	TC kW	PI kW	TC kW	PI kW	TC kW	PI kW	TC kW	PI kW	TC kW	PI kW	TC kW	PI kW
90%	-5	4.32	0.80	5.26	0.82	6.12	0.92	7.20	1.02	7.21	1.12	7.23	1.23	7.58	1.43
	-2	4.32	0.81	5.26	0.83	6.12	0.94	7.20	1.04	7.21	1.14	7.23	1.25	7.58	1.45
	0	4.32	0.82	5.26	0.84	6.12	0.95	7.20	1.06	7.21	1.16	7.23	1.27	7.58	1.48
	2	4.32	0.84	5.26	0.86	6.12	0.97	7.20	1.07	7.21	1.18	7.23	1.29	7.58	1.50
	4	4.32	0.85	5.26	0.87	6.12	0.98	7.20	1.09	7.21	1.20	7.23	1.31	7.58	1.53
	6	4.32	0.86	5.26	0.89	6.12	1.00	7.20	1.11	7.21	1.22	7.23	1.33	7.58	1.55
	8	4.32	0.88	5.26	0.90	6.12	1.01	7.20	1.12	7.21	1.24	7.23	1.35	7.58	1.57
	10	4.32	0.89	5.26	0.91	6.12	1.03	7.20	1.14	7.21	1.25	7.23	1.37	7.58	1.60
	12	4.32	0.90	5.26	0.93	6.12	1.04	7.20	1.16	7.21	1.27	7.23	1.39	7.58	1.62
	14	4.32	0.92	5.26	0.94	6.12	1.06	7.20	1.17	7.21	1.29	7.23	1.41	7.58	1.64
	16	4.32	0.93	5.26	0.95	6.12	1.07	7.20	1.19	7.21	1.31	7.23	1.43	7.58	1.67
	18	4.32	0.94	5.26	0.97	6.12	1.09	7.20	1.21	7.21	1.33	7.23	1.45	7.58	1.69
	20	4.32	0.95	5.26	0.98	6.12	1.10	7.20	1.22	7.21	1.35	7.23	1.47	7.58	1.71
	21	4.32	0.97	5.26	0.99	6.12	1.12	7.20	1.24	7.21	1.36	7.23	1.49	7.58	1.74
	23	4.32	0.98	5.26	1.01	6.12	1.13	7.20	1.26	7.21	1.38	7.23	1.51	7.58	1.76
	25	4.32	0.99	5.26	1.02	6.12	1.15	7.20	1.27	7.21	1.40	7.23	1.53	7.58	1.78
	27	4.32	1.01	5.26	1.03	6.12	1.16	7.20	1.29	7.21	1.42	7.23	1.55	7.58	1.81
	29	4.32	1.03	5.26	1.06	6.12	1.19	7.20	1.32	7.21	1.46	7.23	1.59	7.58	1.85
	31	4.32	1.09	5.26	1.11	6.12	1.25	7.20	1.39	7.21	1.53	7.23	1.60	7.58	1.95
	33	4.32	1.19	5.26	1.22	6.12	1.37	7.20	1.53	7.21	1.68	7.23	1.69	7.58	2.06
35	4.32	1.31	5.26	1.34	6.12	1.51	7.20	1.68	7.21	1.76	7.23	1.86	7.58	2.16	
37	4.06	1.30	4.94	1.34	5.75	1.50	6.77	1.67	6.78	1.76	6.80	1.86	7.13	2.12	
39	3.89	1.35	4.73	1.38	5.51	1.55	6.48	1.73	6.49	1.81	6.51	1.92	6.82	2.19	
41	3.67	1.37	4.47	1.41	5.20	1.58	6.12	1.76	6.13	1.85	6.15	1.95	6.44	2.19	
43	3.46	1.40	4.20	1.43	4.90	1.61	5.76	1.79	5.77	1.88	5.79	1.99	6.06	2.18	
45	3.24	1.49	3.94	1.53	4.59	1.72	5.40	1.91	5.41	2.01	5.43	2.12	5.69	2.29	
48	3.02	1.54	3.68	1.58	4.28	1.78	5.04	1.98	5.05	2.14	5.06	2.20	5.31	2.35	
80%	-5	3.84	0.66	4.67	0.67	5.44	0.76	6.40	0.84	6.41	0.93	6.43	1.01	6.74	1.18
	-2	3.84	0.67	4.67	0.69	5.44	0.77	6.40	0.86	6.41	0.94	6.43	1.03	6.74	1.20
	0	3.84	0.68	4.67	0.70	5.44	0.78	6.40	0.87	6.41	0.96	6.43	1.04	6.74	1.22
	2	3.84	0.69	4.67	0.71	5.44	0.80	6.40	0.88	6.41	0.97	6.43	1.06	6.74	1.24
	4	3.84	0.70	4.67	0.72	5.44	0.81	6.40	0.90	6.41	0.99	6.43	1.08	6.74	1.26
	6	3.84	0.71	4.67	0.73	5.44	0.82	6.40	0.91	6.41	1.00	6.43	1.09	6.74	1.28
	8	3.84	0.72	4.67	0.74	5.44	0.83	6.40	0.93	6.41	1.02	6.43	1.11	6.74	1.30
	10	3.84	0.73	4.67	0.75	5.44	0.85	6.40	0.94	6.41	1.03	6.43	1.13	6.74	1.31
	12	3.84	0.74	4.67	0.76	5.44	0.86	6.40	0.95	6.41	1.05	6.43	1.14	6.74	1.33
	14	3.84	0.75	4.67	0.77	5.44	0.87	6.40	0.97	6.41	1.06	6.43	1.16	6.74	1.35
	16	3.84	0.76	4.67	0.78	5.44	0.88	6.40	0.98	6.41	1.08	6.43	1.18	6.74	1.37
	18	3.84	0.78	4.67	0.80	5.44	0.90	6.40	0.99	6.41	1.09	6.43	1.19	6.74	1.39
	20	3.84	0.79	4.67	0.81	5.44	0.91	6.40	1.01	6.41	1.11	6.43	1.21	6.74	1.41
	21	3.84	0.80	4.67	0.82	5.44	0.92	6.40	1.02	6.41	1.12	6.43	1.23	6.74	1.43
	23	3.84	0.81	4.67	0.83	5.44	0.93	6.40	1.04	6.41	1.14	6.43	1.24	6.74	1.45
	25	3.84	0.82	4.67	0.84	5.44	0.94	6.40	1.05	6.41	1.15	6.43	1.26	6.74	1.47
	27	3.84	0.83	4.67	0.85	5.44	0.96	6.40	1.06	6.41	1.17	6.43	1.28	6.74	1.49
	29	3.84	0.85	4.67	0.87	5.44	0.98	6.40	1.09	6.41	1.20	6.43	1.31	6.74	1.53
	31	3.84	0.89	4.67	0.92	5.44	1.03	6.40	1.15	6.41	1.26	6.43	1.32	6.74	1.61
	33	3.84	0.98	4.67	1.01	5.44	1.13	6.40	1.26	6.41	1.38	6.43	1.40	6.74	1.70
35	3.84	1.08	4.67	1.11	5.44	1.24	6.40	1.38	6.41	1.45	6.43	1.53	6.74	1.78	
37	3.61	1.07	4.39	1.10	5.11	1.24	6.02	1.38	6.03	1.45	6.04	1.53	6.33	1.75	
39	3.46	1.11	4.20	1.14	4.90	1.28	5.76	1.42	5.77	1.49	5.79	1.58	6.06	1.81	
41	3.26	1.13	3.97	1.16	4.62	1.31	5.44	1.45	5.45	1.52	5.47	1.61	5.73	1.80	
43	3.07	1.15	3.74	1.18	4.35	1.33	5.12	1.48	5.13	1.55	5.14	1.64	5.39	1.79	
45	2.88	1.23	3.50	1.26	4.08	1.42	4.80	1.57	4.81	1.65	4.82	1.75	5.05	1.89	
48	2.69	1.27	3.27	1.30	3.81	1.47	4.48	1.63	4.49	1.76	4.50	1.81	4.72	1.93	

Abbreviations:

CR: Combination ratio

TC: Total capacity (kW)

PI: Power input (compressor + outdoor fan motor) (kW)

Notes:

1. Shaded cells indicate rating condition.

Table continued on next page ...

Table 2-8.1: BCSF030N0A4-DTM090 cooling capacity (continued)

CR	Outdoor air temp. (°C DB)	Indoor air temp. (°C DB / °C WB)													
		20.8 / 14.0		23.3 / 16.0		25.8 / 18.0		27.0 / 19.0		28.2 / 20.0		30.7 / 22.0		32.0 / 24.0	
		TC kW	PI kW	TC kW	PI kW	TC kW	PI kW	TC kW	PI kW	TC kW	PI kW	TC kW	PI kW	TC kW	PI kW
70%	-5	3.36	0.57	4.09	0.58	4.76	0.65	5.60	0.73	5.61	0.80	5.63	0.87	5.90	1.02
	-2	3.36	0.57	4.09	0.59	4.76	0.66	5.60	0.73	5.61	0.81	5.63	0.88	5.90	1.03
	0	3.36	0.58	4.09	0.60	4.76	0.67	5.60	0.74	5.61	0.82	5.63	0.89	5.90	1.04
	2	3.36	0.59	4.09	0.60	4.76	0.68	5.60	0.76	5.61	0.83	5.63	0.91	5.90	1.06
	4	3.36	0.60	4.09	0.61	4.76	0.69	5.60	0.77	5.61	0.84	5.63	0.92	5.90	1.07
	6	3.36	0.61	4.09	0.62	4.76	0.70	5.60	0.78	5.61	0.86	5.63	0.93	5.90	1.09
	8	3.36	0.62	4.09	0.63	4.76	0.71	5.60	0.79	5.61	0.87	5.63	0.95	5.90	1.10
	10	3.36	0.62	4.09	0.64	4.76	0.72	5.60	0.80	5.61	0.88	5.63	0.96	5.90	1.12
	12	3.36	0.63	4.09	0.65	4.76	0.73	5.60	0.81	5.61	0.89	5.63	0.97	5.90	1.14
	14	3.36	0.64	4.09	0.66	4.76	0.74	5.60	0.82	5.61	0.91	5.63	0.99	5.90	1.15
	16	3.36	0.65	4.09	0.67	4.76	0.75	5.60	0.83	5.61	0.92	5.63	1.00	5.90	1.17
	18	3.36	0.66	4.09	0.68	4.76	0.76	5.60	0.85	5.61	0.93	5.63	1.01	5.90	1.18
	20	3.36	0.66	4.09	0.68	4.76	0.77	5.60	0.85	5.61	0.94	5.63	1.02	5.90	1.19
	21	3.36	0.67	4.09	0.69	4.76	0.77	5.60	0.86	5.61	0.94	5.63	1.03	5.90	1.20
	23	3.36	0.67	4.09	0.69	4.76	0.78	5.60	0.86	5.61	0.95	5.63	1.03	5.90	1.21
	25	3.36	0.68	4.09	0.69	4.76	0.78	5.60	0.87	5.61	0.95	5.63	1.04	5.90	1.22
	27	3.36	0.68	4.09	0.70	4.76	0.79	5.60	0.87	5.61	0.96	5.63	1.05	5.90	1.22
	29	3.36	0.69	4.09	0.71	4.76	0.80	5.60	0.89	5.61	0.98	5.63	1.07	5.90	1.25
	31	3.36	0.73	4.09	0.75	4.76	0.84	5.60	0.94	5.61	1.03	5.63	1.08	5.90	1.31
	33	3.36	0.80	4.09	0.82	4.76	0.92	5.60	1.03	5.61	1.13	5.63	1.14	5.90	1.39
35	3.36	0.88	4.09	0.90	4.76	1.01	5.60	1.13	5.61	1.18	5.63	1.25	5.90	1.45	
37	3.16	0.88	3.84	0.90	4.47	1.01	5.26	1.12	5.27	1.18	5.29	1.25	5.54	1.43	
39	3.02	0.91	3.68	0.93	4.28	1.04	5.04	1.16	5.05	1.22	5.06	1.29	5.31	1.47	
41	2.86	0.92	3.47	0.95	4.05	1.07	4.76	1.18	4.77	1.24	4.78	1.31	5.01	1.47	
43	2.69	0.94	3.27	0.96	3.81	1.09	4.48	1.21	4.49	1.27	4.50	1.34	4.72	1.46	
45	2.52	1.00	3.07	1.03	3.57	1.16	4.20	1.28	4.21	1.35	4.22	1.43	4.42	1.54	
48	2.35	1.04	2.86	1.06	3.33	1.20	3.92	1.33	3.93	1.44	3.94	1.48	4.13	1.58	
60%	-5	2.88	0.45	3.50	0.46	4.08	0.52	4.80	0.58	4.81	0.64	4.82	0.69	5.05	0.81
	-2	2.88	0.45	3.50	0.47	4.08	0.52	4.80	0.58	4.81	0.64	4.82	0.70	5.05	0.82
	0	2.88	0.46	3.50	0.47	4.08	0.53	4.80	0.59	4.81	0.65	4.82	0.71	5.05	0.83
	2	2.88	0.47	3.50	0.48	4.08	0.54	4.80	0.60	4.81	0.66	4.82	0.72	5.05	0.84
	4	2.88	0.48	3.50	0.49	4.08	0.55	4.80	0.61	4.81	0.67	4.82	0.73	5.05	0.85
	6	2.88	0.48	3.50	0.49	4.08	0.56	4.80	0.62	4.81	0.68	4.82	0.74	5.05	0.87
	8	2.88	0.49	3.50	0.50	4.08	0.56	4.80	0.63	4.81	0.69	4.82	0.75	5.05	0.88
	10	2.88	0.50	3.50	0.51	4.08	0.57	4.80	0.64	4.81	0.70	4.82	0.76	5.05	0.89
	12	2.88	0.50	3.50	0.52	4.08	0.58	4.80	0.65	4.81	0.71	4.82	0.77	5.05	0.90
	14	2.88	0.51	3.50	0.52	4.08	0.59	4.80	0.65	4.81	0.72	4.82	0.79	5.05	0.92
	16	2.88	0.52	3.50	0.53	4.08	0.60	4.80	0.66	4.81	0.73	4.82	0.80	5.05	0.93
	18	2.88	0.52	3.50	0.54	4.08	0.60	4.80	0.67	4.81	0.74	4.82	0.81	5.05	0.94
	20	2.88	0.53	3.50	0.54	4.08	0.61	4.80	0.68	4.81	0.74	4.82	0.81	5.05	0.95
	21	2.88	0.53	3.50	0.54	4.08	0.61	4.80	0.68	4.81	0.75	4.82	0.82	5.05	0.95
	23	2.88	0.53	3.50	0.55	4.08	0.62	4.80	0.69	4.81	0.75	4.82	0.82	5.05	0.96
	25	2.88	0.54	3.50	0.55	4.08	0.62	4.80	0.69	4.81	0.76	4.82	0.83	5.05	0.97
	27	2.88	0.54	3.50	0.56	4.08	0.63	4.80	0.69	4.81	0.76	4.82	0.83	5.05	0.97
	29	2.88	0.55	3.50	0.57	4.08	0.64	4.80	0.71	4.81	0.78	4.82	0.85	5.05	0.99
	31	2.88	0.58	3.50	0.60	4.08	0.67	4.80	0.74	4.81	0.82	4.82	0.86	5.05	1.04
	33	2.88	0.64	3.50	0.65	4.08	0.73	4.80	0.82	4.81	0.90	4.82	0.91	5.05	1.10
35	2.88	0.70	3.50	0.72	4.08	0.81	4.80	0.90	4.81	0.94	4.82	0.99	5.05	1.15	
37	2.71	0.70	3.29	0.72	3.84	0.80	4.51	0.89	4.52	0.94	4.53	0.99	4.75	1.14	
39	2.59	0.72	3.15	0.74	3.67	0.83	4.32	0.92	4.33	0.97	4.34	1.02	4.55	1.17	
41	2.45	0.73	2.98	0.75	3.47	0.85	4.08	0.94	4.09	0.99	4.10	1.04	4.30	1.17	
43	2.30	0.75	2.80	0.77	3.26	0.86	3.84	0.96	3.85	1.01	3.86	1.06	4.04	1.16	
45	2.16	0.80	2.63	0.82	3.06	0.92	3.60	1.02	3.61	1.07	3.62	1.13	3.79	1.23	
48	2.02	0.82	2.45	0.85	2.86	0.95	3.36	1.06	3.37	1.14	3.38	1.17	3.54	1.26	

Abbreviations:

CR: Combination ratio

TC: Total capacity (kW)

PI: Power input (compressor + outdoor fan motor) (kW)

Notes:

1. Shaded cells indicate rating condition.

Table continued on next page ...

Table 2-8.1: BCSF030N0A4-DTM090 cooling capacity (continued)

CR	Outdoor air temp. (°C DB)	Indoor air temp. (°C DB / °C WB)													
		20.8 / 14.0		23.3 / 16.0		25.8 / 18.0		27.0 / 19.0		28.2 / 20.0		30.7 / 22.0		32.0 / 24.0	
		TC kW	PI kW	TC kW	PI kW	TC kW	PI kW	TC kW	PI kW	TC kW	PI kW	TC kW	PI kW	TC kW	PI kW
50%	-5	2.40	0.35	2.92	0.36	3.40	0.41	4.00	0.45	4.01	0.50	4.02	0.54	4.21	0.63
	-2	2.40	0.35	2.92	0.36	3.40	0.41	4.00	0.45	4.01	0.50	4.02	0.54	4.21	0.64
	0	2.40	0.36	2.92	0.37	3.40	0.41	4.00	0.46	4.01	0.51	4.02	0.55	4.21	0.65
	2	2.40	0.36	2.92	0.37	3.40	0.42	4.00	0.47	4.01	0.51	4.02	0.56	4.21	0.66
	4	2.40	0.37	2.92	0.38	3.40	0.43	4.00	0.47	4.01	0.52	4.02	0.57	4.21	0.66
	6	2.40	0.38	2.92	0.39	3.40	0.43	4.00	0.48	4.01	0.53	4.02	0.58	4.21	0.67
	8	2.40	0.38	2.92	0.39	3.40	0.44	4.00	0.49	4.01	0.54	4.02	0.59	4.21	0.68
	10	2.40	0.39	2.92	0.40	3.40	0.45	4.00	0.50	4.01	0.55	4.02	0.60	4.21	0.69
	12	2.40	0.39	2.92	0.40	3.40	0.45	4.00	0.50	4.01	0.55	4.02	0.60	4.21	0.70
	14	2.40	0.40	2.92	0.41	3.40	0.46	4.00	0.51	4.01	0.56	4.02	0.61	4.21	0.71
	16	2.40	0.40	2.92	0.41	3.40	0.47	4.00	0.52	4.01	0.57	4.02	0.62	4.21	0.72
	18	2.40	0.41	2.92	0.42	3.40	0.47	4.00	0.52	4.01	0.58	4.02	0.63	4.21	0.73
	20	2.40	0.41	2.92	0.42	3.40	0.47	4.00	0.53	4.01	0.58	4.02	0.63	4.21	0.74
	21	2.40	0.41	2.92	0.42	3.40	0.48	4.00	0.53	4.01	0.58	4.02	0.64	4.21	0.74
	23	2.40	0.42	2.92	0.43	3.40	0.48	4.00	0.53	4.01	0.59	4.02	0.64	4.21	0.75
	25	2.40	0.42	2.92	0.43	3.40	0.48	4.00	0.54	4.01	0.59	4.02	0.65	4.21	0.75
	27	2.40	0.42	2.92	0.43	3.40	0.49	4.00	0.54	4.01	0.60	4.02	0.65	4.21	0.76
	29	2.40	0.43	2.92	0.44	3.40	0.50	4.00	0.55	4.01	0.61	4.02	0.66	4.21	0.77
	31	2.40	0.45	2.92	0.46	3.40	0.52	4.00	0.58	4.01	0.64	4.02	0.67	4.21	0.81
	33	2.40	0.50	2.92	0.51	3.40	0.57	4.00	0.64	4.01	0.70	4.02	0.71	4.21	0.86
35	2.40	0.54	2.92	0.56	3.40	0.63	4.00	0.70	4.01	0.73	4.02	0.78	4.21	0.90	
37	2.26	0.54	2.74	0.56	3.20	0.63	3.76	0.70	3.77	0.73	3.78	0.77	3.96	0.88	
39	2.16	0.56	2.63	0.58	3.06	0.65	3.60	0.72	3.61	0.76	3.62	0.80	3.79	0.91	
41	2.04	0.57	2.48	0.59	2.89	0.66	3.40	0.73	3.41	0.77	3.42	0.81	3.58	0.91	
43	1.92	0.58	2.34	0.60	2.72	0.67	3.20	0.75	3.21	0.78	3.21	0.83	3.37	0.91	
45	1.80	0.62	2.19	0.64	2.55	0.72	3.00	0.80	3.01	0.84	3.01	0.88	3.16	0.96	
48	1.68	0.64	2.04	0.66	2.38	0.74	2.80	0.82	2.80	0.89	2.81	0.91	2.95	0.98	

Abbreviations:

CR: Combination ratio

TC: Total capacity (kW)

PI: Power input (compressor + outdoor fan motor) (kW)

Notes:

1. Shaded cells indicate rating condition.

Table 2-8.2: BCSF040NOA6-DTM115 cooling capacity

CR	Outdoor air temp. (°C DB)	Indoor air temp. (°C DB / °C WB)													
		20.8 / 14.0		23.3 / 16.0		25.8 / 18.0		27.0 / 19.0		28.2 / 20.0		30.7 / 22.0		32.0 / 24.0	
		TC kW	PI kW	TC kW	PI kW	TC kW	PI kW	TC kW	PI kW	TC kW	PI kW	TC kW	PI kW	TC kW	PI kW
130%	-5	7.80	1.57	9.10	1.61	11.05	1.81	13.00	2.02	13.39	2.22	13.65	2.42	14.04	2.82
	-2	7.80	1.61	9.10	1.65	11.05	1.86	13.00	2.06	13.39	2.27	13.65	2.47	14.04	2.89
	0	7.80	1.61	9.10	1.65	11.05	1.86	13.00	2.06	13.39	2.27	13.65	2.47	14.04	2.89
	2	7.80	1.61	9.10	1.65	11.05	1.86	13.00	2.06	13.39	2.27	13.65	2.47	14.04	2.89
	4	7.80	1.64	9.10	1.69	11.05	1.90	13.00	2.11	13.39	2.32	13.65	2.53	14.04	2.95
	6	7.80	1.64	9.10	1.69	11.05	1.90	13.00	2.11	13.39	2.32	13.65	2.53	14.04	2.95
	8	7.80	1.64	9.10	1.69	11.05	1.90	13.00	2.11	13.39	2.32	13.65	2.53	14.04	2.95
	10	7.80	1.68	9.10	1.72	11.05	1.94	13.00	2.15	13.39	2.37	13.65	2.58	14.04	3.02
	12	7.80	1.72	9.10	1.76	11.05	1.98	13.00	2.20	13.39	2.42	13.65	2.64	14.04	3.08
	14	7.80	1.75	9.10	1.80	11.05	2.02	13.00	2.25	13.39	2.47	13.65	2.69	14.04	3.14
	16	7.80	1.82	9.10	1.87	11.05	2.10	13.00	2.34	13.39	2.57	13.65	2.80	14.04	3.27
	18	7.80	1.89	9.10	1.94	11.05	2.19	13.00	2.43	13.39	2.67	13.65	2.91	14.04	3.40
	20	7.80	2.07	9.10	2.13	11.05	2.39	13.00	2.66	13.39	2.92	13.65	3.19	14.04	3.72
	21	7.80	2.18	9.10	2.24	11.05	2.52	13.00	2.80	13.39	3.07	13.65	3.35	14.04	3.91
	23	7.80	2.29	9.10	2.35	11.05	2.64	13.00	2.93	13.39	3.23	13.65	3.52	14.04	3.98
	25	7.80	2.39	9.10	2.46	11.05	2.76	13.00	3.07	13.39	3.38	13.65	3.68	14.04	4.00
	27	7.80	2.50	9.10	2.57	11.05	2.89	13.00	3.21	13.39	3.50	13.65	3.85	14.04	4.13
	29	7.80	2.57	9.10	2.64	11.05	2.97	13.00	3.31	13.39	3.73	13.65	3.96	14.04	4.16
	31	7.80	2.61	9.10	2.68	11.05	3.01	13.00	3.30	13.39	3.82	13.65	3.85	14.04	4.21
	33	7.80	2.65	9.10	2.71	11.05	3.05	13.00	3.40	13.39	3.91	13.65	3.76	14.04	4.13
35	7.80	2.75	9.10	2.82	11.05	3.17	13.00	3.47	13.39	4.00	13.65	4.15	14.04	4.29	
37	6.24	2.98	7.28	3.01	8.84	3.16	10.40	3.56	10.42	4.19	10.45	4.24	10.95	4.38	
39	5.85	3.04	6.83	3.07	8.29	3.52	9.75	3.91	9.77	4.27	9.81	4.98	10.26	5.21	
41	5.46	3.14	6.37	3.19	7.74	3.81	9.10	4.22	9.16	4.44	9.24	5.32	9.58	5.38	
43	5.07	3.38	5.92	3.54	7.18	3.92	8.45	4.33	8.71	4.58	8.79	5.43	9.28	5.49	
45	4.68	3.52	5.46	3.77	6.63	4.08	7.80	4.52	8.42	4.72	8.84	5.51	8.98	5.67	
48	4.29	3.74	5.01	3.98	6.08	4.23	7.15	4.76	8.16	5.04	8.18	5.64	8.23	5.81	
120%	-5	7.20	1.41	8.76	1.45	10.20	1.63	12.00	1.81	12.02	1.99	12.06	2.17	12.63	2.54
	-2	7.20	1.44	8.76	1.48	10.20	1.67	12.00	1.85	12.02	2.04	12.06	2.22	12.63	2.59
	0	7.20	1.44	8.76	1.48	10.20	1.67	12.00	1.85	12.02	2.04	12.06	2.22	12.63	2.59
	2	7.20	1.44	8.76	1.48	10.20	1.67	12.00	1.85	12.02	2.04	12.06	2.22	12.63	2.59
	4	7.20	1.48	8.76	1.51	10.20	1.70	12.00	1.89	12.02	2.08	12.06	2.27	12.63	2.65
	6	7.20	1.48	8.76	1.51	10.20	1.70	12.00	1.89	12.02	2.08	12.06	2.27	12.63	2.65
	8	7.20	1.48	8.76	1.51	10.20	1.70	12.00	1.89	12.02	2.08	12.06	2.27	12.63	2.65
	10	7.20	1.51	8.76	1.55	10.20	1.74	12.00	1.93	12.02	2.13	12.06	2.32	12.63	2.71
	12	7.20	1.54	8.76	1.58	10.20	1.78	12.00	1.98	12.02	2.17	12.06	2.37	12.63	2.77
	14	7.20	1.57	8.76	1.61	10.20	1.81	12.00	2.02	12.02	2.22	12.06	2.42	12.63	2.82
	16	7.20	1.64	8.76	1.68	10.20	1.89	12.00	2.10	12.02	2.31	12.06	2.52	12.63	2.94
	18	7.20	1.70	8.76	1.74	10.20	1.96	12.00	2.18	12.02	2.40	12.06	2.62	12.63	3.05
	20	7.20	1.86	8.76	1.91	10.20	2.15	12.00	2.39	12.02	2.63	12.06	2.86	12.63	3.34
	21	7.20	1.96	8.76	2.01	10.20	2.26	12.00	2.51	12.02	2.76	12.06	3.01	12.63	3.51
	23	7.20	2.05	8.76	2.11	10.20	2.37	12.00	2.63	12.02	2.90	12.06	3.16	12.63	3.69
	25	7.20	2.15	8.76	2.21	10.20	2.48	12.00	2.76	12.02	3.03	12.06	3.31	12.63	3.86
	27	7.20	2.34	8.76	2.40	10.20	2.70	12.00	3.00	12.02	3.30	12.06	3.61	12.63	4.21
	29	7.20	2.50	8.76	2.57	10.20	2.89	12.00	3.21	12.02	3.53	12.06	3.85	12.63	4.49
	31	7.20	2.57	8.76	2.63	10.20	2.96	12.00	3.29	12.02	3.62	12.06	3.79	12.63	4.61
	33	7.20	2.63	8.76	2.70	10.20	3.04	12.00	3.37	12.02	3.71	12.06	3.75	12.63	4.56
35	7.20	2.67	8.76	2.74	10.20	3.09	12.00	3.43	12.02	3.60	12.06	3.81	12.63	4.42	
37	6.77	2.67	8.23	2.74	9.59	3.08	11.28	3.42	11.30	3.59	11.33	3.80	11.88	4.34	
39	6.48	3.02	7.88	3.10	9.18	3.49	10.80	3.88	10.82	4.07	10.85	4.30	11.37	4.76	
41	6.12	3.21	7.45	3.29	8.67	3.70	10.20	4.12	10.22	4.32	10.25	4.57	10.74	4.83	
43	5.76	3.34	7.01	3.43	8.16	3.86	9.60	4.29	9.62	4.50	9.64	4.76	10.11	4.91	
45	5.40	3.48	6.57	3.57	7.65	4.01	9.00	4.46	9.02	4.68	9.04	4.95	9.48	5.04	
48	5.04	3.64	6.13	3.73	7.14	4.20	8.40	4.66	8.41	5.04	8.44	5.08	8.84	5.15	

Abbreviations:

CR: Combination ratio

TC: Total capacity (kW)

PI: Power input (compressor + outdoor fan motor) (kW)

Notes:

1. Shaded cells indicate rating condition.

Table continued on next page ...

Table 2-8.2: BCSF040NOA6-DTM115 cooling capacity (continued)

CR	Outdoor air temp. (°C DB)	Indoor air temp. (°C DB / °C WB)													
		20.8 / 14.0		23.3 / 16.0		25.8 / 18.0		27.0 / 19.0		28.2 / 20.0		30.7 / 22.0		32.0 / 24.0	
		TC kW	PI kW	TC kW	PI kW	TC kW	PI kW	TC kW	PI kW	TC kW	PI kW	TC kW	PI kW	TC kW	PI kW
110%	-5	6.60	1.27	8.03	1.30	9.35	1.47	11.00	1.63	11.02	1.79	11.05	1.96	11.58	2.28
	-2	6.60	1.30	8.03	1.33	9.35	1.50	11.00	1.66	11.02	1.83	11.05	1.99	11.58	2.33
	0	6.60	1.32	8.03	1.36	9.35	1.52	11.00	1.69	11.02	1.86	11.05	2.03	11.58	2.37
	2	6.60	1.35	8.03	1.38	9.35	1.55	11.00	1.73	11.02	1.90	11.05	2.07	11.58	2.42
	4	6.60	1.37	8.03	1.41	9.35	1.58	11.00	1.76	11.02	1.93	11.05	2.11	11.58	2.46
	6	6.60	1.40	8.03	1.43	9.35	1.61	11.00	1.79	11.02	1.97	11.05	2.15	11.58	2.51
	8	6.60	1.42	8.03	1.46	9.35	1.64	11.00	1.82	11.02	2.00	11.05	2.19	11.58	2.55
	10	6.60	1.45	8.03	1.48	9.35	1.67	11.00	1.85	11.02	2.04	11.05	2.22	11.58	2.60
	12	6.60	1.47	8.03	1.51	9.35	1.70	11.00	1.89	11.02	2.07	11.05	2.26	11.58	2.64
	14	6.60	1.50	8.03	1.53	9.35	1.73	11.00	1.92	11.02	2.11	11.05	2.30	11.58	2.68
	16	6.60	1.52	8.03	1.56	9.35	1.75	11.00	1.95	11.02	2.14	11.05	2.34	11.58	2.73
	18	6.60	1.57	8.03	1.61	9.35	1.81	11.00	2.01	11.02	2.22	11.05	2.42	11.58	2.82
	20	6.60	1.70	8.03	1.74	9.35	1.96	11.00	2.17	11.02	2.39	11.05	2.61	11.58	3.04
	21	6.60	1.77	8.03	1.82	9.35	2.04	11.00	2.27	11.02	2.50	11.05	2.72	11.58	3.18
	23	6.60	1.84	8.03	1.89	9.35	2.13	11.00	2.37	11.02	2.60	11.05	2.84	11.58	3.31
	25	6.60	1.92	8.03	1.97	9.35	2.22	11.00	2.46	11.02	2.71	11.05	2.95	11.58	3.45
	27	6.60	1.97	8.03	2.02	9.35	2.27	11.00	2.53	11.02	2.78	11.05	3.03	11.58	3.54
	29	6.60	2.02	8.03	2.07	9.35	2.33	11.00	2.59	11.02	2.85	11.05	3.11	11.58	3.62
	31	6.60	2.12	8.03	2.17	9.35	2.45	11.00	2.72	11.02	2.99	11.05	3.12	11.58	3.80
	33	6.60	2.17	8.03	2.22	9.35	2.50	11.00	2.78	11.02	3.06	11.05	3.09	11.58	3.76
35	6.60	2.27	8.03	2.32	9.35	2.62	11.00	2.91	11.02	3.05	11.05	3.23	11.58	3.74	
37	6.20	2.26	7.55	2.32	8.79	2.61	10.34	2.90	10.36	3.04	10.39	3.22	10.89	3.68	
39	5.94	2.56	7.23	2.63	8.42	2.96	9.90	3.28	9.92	3.45	9.95	3.64	10.42	4.08	
41	5.61	2.72	6.83	2.79	7.95	3.14	9.35	3.49	9.37	3.66	9.39	3.87	9.84	4.19	
43	5.28	2.83	6.42	2.91	7.48	3.27	8.80	3.63	8.82	3.81	8.84	4.03	9.26	4.26	
45	4.95	2.95	6.02	3.02	7.01	3.40	8.25	3.78	8.26	3.97	8.29	4.19	8.69	4.38	
48	4.62	3.08	5.62	3.16	6.55	3.56	7.70	3.95	7.71	4.27	7.74	4.31	8.11	4.44	
100%	-5	6.00	1.12	7.30	1.15	8.50	1.29	10.00	1.43	10.02	1.58	10.05	1.72	10.53	2.01
	-2	6.00	1.14	7.30	1.17	8.50	1.31	10.00	1.46	10.02	1.60	10.05	1.75	10.53	2.04
	0	6.00	1.15	7.30	1.18	8.50	1.33	10.00	1.48	10.02	1.63	10.05	1.78	10.53	2.07
	2	6.00	1.17	7.30	1.20	8.50	1.35	10.00	1.50	10.02	1.65	10.05	1.80	10.53	2.11
	4	6.00	1.19	7.30	1.22	8.50	1.37	10.00	1.53	10.02	1.68	10.05	1.83	10.53	2.14
	6	6.00	1.21	7.30	1.24	8.50	1.40	10.00	1.55	10.02	1.71	10.05	1.86	10.53	2.17
	8	6.00	1.23	7.30	1.26	8.50	1.42	10.00	1.57	10.02	1.73	10.05	1.89	10.53	2.20
	10	6.00	1.25	7.30	1.28	8.50	1.44	10.00	1.60	10.02	1.76	10.05	1.92	10.53	2.24
	12	6.00	1.26	7.30	1.30	8.50	1.46	10.00	1.62	10.02	1.78	10.05	1.95	10.53	2.27
	14	6.00	1.28	7.30	1.32	8.50	1.48	10.00	1.65	10.02	1.81	10.05	1.97	10.53	2.30
	16	6.00	1.30	7.30	1.33	8.50	1.50	10.00	1.67	10.02	1.84	10.05	2.00	10.53	2.34
	18	6.00	1.32	7.30	1.35	8.50	1.52	10.00	1.69	10.02	1.86	10.05	2.03	10.53	2.37
	20	6.00	1.34	7.30	1.37	8.50	1.54	10.00	1.72	10.02	1.89	10.05	2.06	10.53	2.40
	21	6.00	1.36	7.30	1.39	8.50	1.57	10.00	1.74	10.02	1.91	10.05	2.09	10.53	2.43
	23	6.00	1.37	7.30	1.41	8.50	1.59	10.00	1.76	10.02	1.94	10.05	2.12	10.53	2.47
	25	6.00	1.39	7.30	1.43	8.50	1.61	10.00	1.79	10.02	1.96	10.05	2.14	10.53	2.50
	27	6.00	1.41	7.30	1.45	8.50	1.63	10.00	1.81	10.02	1.99	10.05	2.17	10.53	2.53
	29	6.00	1.45	7.30	1.49	8.50	1.67	10.00	1.86	10.02	2.04	10.05	2.23	10.53	2.60
	31	6.00	1.52	7.30	1.56	8.50	1.76	10.00	1.95	10.02	2.15	10.05	2.24	10.53	2.73
	33	6.00	1.67	7.30	1.71	8.50	1.92	10.00	2.14	10.02	2.35	10.05	2.37	10.53	2.89
35	6.00	1.83	7.30	1.88	8.50	2.12	10.00	2.35	10.02	2.47	10.05	2.61	10.53	3.03	
37	5.64	1.83	6.86	1.88	7.99	2.11	9.40	2.34	9.42	2.46	9.44	2.60	9.90	2.98	
39	5.40	2.07	6.57	2.12	7.65	2.39	9.00	2.66	9.02	2.79	9.04	2.95	9.48	3.37	
41	5.10	2.20	6.21	2.26	7.23	2.54	8.50	2.82	8.51	2.96	8.54	3.13	8.95	3.50	
43	4.80	2.29	5.84	2.35	6.80	2.64	8.00	2.94	8.01	3.08	8.04	3.26	8.42	3.57	
45	4.50	2.38	5.48	2.44	6.38	2.75	7.50	3.06	7.51	3.21	7.53	3.39	7.90	3.67	
48	4.20	2.49	5.11	2.56	5.95	2.88	7.00	3.20	7.01	3.45	7.03	3.55	7.37	3.79	

Abbreviations:

CR: Combination ratio

TC: Total capacity (kW)

PI: Power input (compressor + outdoor fan motor) (kW)

Notes:

1. Shaded cells indicate rating condition.

Table continued on next page ...

Table 2-8.2: BCSF040NOA6-DTM115 cooling capacity (continued)

CR	Outdoor air temp. (°C DB)	Indoor air temp. (°C DB / °C WB)													
		20.8 / 14.0		23.3 / 16.0		25.8 / 18.0		27.0 / 19.0		28.2 / 20.0		30.7 / 22.0		32.0 / 24.0	
		TC kW	PI kW	TC kW	PI kW	TC kW	PI kW	TC kW	PI kW	TC kW	PI kW	TC kW	PI kW	TC kW	PI kW
90%	-5	5.40	0.97	6.57	0.99	7.65	1.11	9.00	1.24	9.02	1.36	9.04	1.49	9.48	1.73
	-2	5.40	0.98	6.57	1.01	7.65	1.13	9.00	1.26	9.02	1.38	9.04	1.51	9.48	1.76
	0	5.40	1.00	6.57	1.02	7.65	1.15	9.00	1.28	9.02	1.41	9.04	1.53	9.48	1.79
	2	5.40	1.01	6.57	1.04	7.65	1.17	9.00	1.30	9.02	1.43	9.04	1.56	9.48	1.82
	4	5.40	1.03	6.57	1.06	7.65	1.19	9.00	1.32	9.02	1.45	9.04	1.58	9.48	1.85
	6	5.40	1.05	6.57	1.07	7.65	1.21	9.00	1.34	9.02	1.47	9.04	1.61	9.48	1.88
	8	5.40	1.06	6.57	1.09	7.65	1.22	9.00	1.36	9.02	1.50	9.04	1.63	9.48	1.90
	10	5.40	1.08	6.57	1.10	7.65	1.24	9.00	1.38	9.02	1.52	9.04	1.66	9.48	1.93
	12	5.40	1.09	6.57	1.12	7.65	1.26	9.00	1.40	9.02	1.54	9.04	1.68	9.48	1.96
	14	5.40	1.11	6.57	1.14	7.65	1.28	9.00	1.42	9.02	1.56	9.04	1.71	9.48	1.99
	16	5.40	1.12	6.57	1.15	7.65	1.30	9.00	1.44	9.02	1.59	9.04	1.73	9.48	2.02
	18	5.40	1.14	6.57	1.17	7.65	1.32	9.00	1.46	9.02	1.61	9.04	1.75	9.48	2.05
	20	5.40	1.16	6.57	1.19	7.65	1.33	9.00	1.48	9.02	1.63	9.04	1.78	9.48	2.08
	21	5.40	1.17	6.57	1.20	7.65	1.35	9.00	1.50	9.02	1.65	9.04	1.80	9.48	2.10
	23	5.40	1.19	6.57	1.22	7.65	1.37	9.00	1.52	9.02	1.68	9.04	1.83	9.48	2.13
	25	5.40	1.20	6.57	1.23	7.65	1.39	9.00	1.54	9.02	1.70	9.04	1.85	9.48	2.16
	27	5.40	1.22	6.57	1.25	7.65	1.41	9.00	1.56	9.02	1.72	9.04	1.88	9.48	2.19
	29	5.40	1.25	6.57	1.28	7.65	1.44	9.00	1.60	9.02	1.76	9.04	1.92	9.48	2.25
	31	5.40	1.31	6.57	1.35	7.65	1.52	9.00	1.69	9.02	1.85	9.04	1.94	9.48	2.36
	33	5.40	1.44	6.57	1.48	7.65	1.66	9.00	1.85	9.02	2.03	9.04	2.05	9.48	2.50
35	5.40	1.58	6.57	1.62	7.65	1.83	9.00	2.03	9.02	2.13	9.04	2.25	9.48	2.62	
37	5.08	1.58	6.18	1.62	7.19	1.82	8.46	2.03	8.47	2.13	8.50	2.25	8.91	2.57	
39	4.86	1.63	5.91	1.67	6.89	1.88	8.10	2.09	8.11	2.20	8.14	2.32	8.53	2.66	
41	4.59	1.66	5.58	1.71	6.50	1.92	7.65	2.13	7.66	2.24	7.69	2.37	8.05	2.65	
43	4.32	1.69	5.26	1.74	6.12	1.96	7.20	2.17	7.21	2.28	7.23	2.41	7.58	2.64	
45	4.05	1.81	4.93	1.85	5.74	2.08	6.75	2.31	6.76	2.43	6.78	2.57	7.11	2.78	
48	3.78	1.87	4.60	1.92	5.36	2.16	6.30	2.40	6.31	2.59	6.33	2.66	6.63	2.84	
80%	-5	4.80	0.80	5.84	0.82	6.80	0.92	8.00	1.02	8.01	1.12	8.04	1.22	8.42	1.43
	-2	4.80	0.81	5.84	0.83	6.80	0.93	8.00	1.04	8.01	1.14	8.04	1.24	8.42	1.45
	0	4.80	0.82	5.84	0.84	6.80	0.95	8.00	1.05	8.01	1.16	8.04	1.26	8.42	1.48
	2	4.80	0.84	5.84	0.86	6.80	0.96	8.00	1.07	8.01	1.18	8.04	1.29	8.42	1.50
	4	4.80	0.85	5.84	0.87	6.80	0.98	8.00	1.09	8.01	1.20	8.04	1.31	8.42	1.52
	6	4.80	0.86	5.84	0.88	6.80	0.99	8.00	1.10	8.01	1.21	8.04	1.33	8.42	1.55
	8	4.80	0.87	5.84	0.90	6.80	1.01	8.00	1.12	8.01	1.23	8.04	1.35	8.42	1.57
	10	4.80	0.89	5.84	0.91	6.80	1.02	8.00	1.14	8.01	1.25	8.04	1.37	8.42	1.59
	12	4.80	0.90	5.84	0.92	6.80	1.04	8.00	1.15	8.01	1.27	8.04	1.39	8.42	1.62
	14	4.80	0.91	5.84	0.94	6.80	1.05	8.00	1.17	8.01	1.29	8.04	1.41	8.42	1.64
	16	4.80	0.93	5.84	0.95	6.80	1.07	8.00	1.19	8.01	1.31	8.04	1.43	8.42	1.66
	18	4.80	0.94	5.84	0.96	6.80	1.08	8.00	1.20	8.01	1.33	8.04	1.45	8.42	1.69
	20	4.80	0.95	5.84	0.98	6.80	1.10	8.00	1.22	8.01	1.34	8.04	1.47	8.42	1.71
	21	4.80	0.97	5.84	0.99	6.80	1.11	8.00	1.24	8.01	1.36	8.04	1.49	8.42	1.73
	23	4.80	0.98	5.84	1.00	6.80	1.13	8.00	1.25	8.01	1.38	8.04	1.51	8.42	1.76
	25	4.80	0.99	5.84	1.02	6.80	1.14	8.00	1.27	8.01	1.40	8.04	1.53	8.42	1.78
	27	4.80	1.00	5.84	1.03	6.80	1.16	8.00	1.29	8.01	1.42	8.04	1.55	8.42	1.80
	29	4.80	1.03	5.84	1.06	6.80	1.19	8.00	1.32	8.01	1.45	8.04	1.59	8.42	1.85
	31	4.80	1.08	5.84	1.11	6.80	1.25	8.00	1.39	8.01	1.53	8.04	1.60	8.42	1.94
	33	4.80	1.19	5.84	1.22	6.80	1.37	8.00	1.52	8.01	1.67	8.04	1.69	8.42	2.06
35	4.80	1.31	5.84	1.34	6.80	1.51	8.00	1.67	8.01	1.76	8.04	1.86	8.42	2.16	
37	4.51	1.30	5.49	1.34	6.39	1.50	7.52	1.67	7.53	1.75	7.55	1.85	7.92	2.12	
39	4.32	1.34	5.26	1.38	6.12	1.55	7.20	1.72	7.21	1.81	7.23	1.91	7.58	2.19	
41	4.08	1.37	4.96	1.41	5.78	1.58	6.80	1.76	6.81	1.84	6.83	1.95	7.16	2.18	
43	3.84	1.40	4.67	1.43	5.44	1.61	6.40	1.79	6.41	1.88	6.43	1.99	6.74	2.17	
45	3.60	1.49	4.38	1.53	5.10	1.72	6.00	1.91	6.01	2.00	6.03	2.12	6.32	2.29	
48	3.36	1.54	4.09	1.58	4.76	1.78	5.60	1.97	5.61	2.13	5.63	2.19	5.90	2.34	

Abbreviations:

CR: Combination ratio

TC: Total capacity (kW)

PI: Power input (compressor + outdoor fan motor) (kW)

Notes:

1. Shaded cells indicate rating condition.

Table continued on next page ...

Table 2-8.2: BCSF040NOA6-DTM115 cooling capacity (continued)

CR	Outdoor air temp. (°C DB)	Indoor air temp. (°C DB / °C WB)													
		20.8 / 14.0		23.3 / 16.0		25.8 / 18.0		27.0 / 19.0		28.2 / 20.0		30.7 / 22.0		32.0 / 24.0	
		TC kW	PI kW	TC kW	PI kW	TC kW	PI kW	TC kW	PI kW	TC kW	PI kW	TC kW	PI kW	TC kW	PI kW
70%	-5	4.20	0.69	5.11	0.70	5.95	0.79	7.00	0.88	7.01	0.97	7.03	1.06	7.37	1.23
	-2	4.20	0.69	5.11	0.71	5.95	0.80	7.00	0.89	7.01	0.98	7.03	1.06	7.37	1.24
	0	4.20	0.70	5.11	0.72	5.95	0.81	7.00	0.90	7.01	0.99	7.03	1.08	7.37	1.26
	2	4.20	0.71	5.11	0.73	5.95	0.82	7.00	0.91	7.01	1.01	7.03	1.10	7.37	1.28
	4	4.20	0.72	5.11	0.74	5.95	0.84	7.00	0.93	7.01	1.02	7.03	1.11	7.37	1.30
	6	4.20	0.73	5.11	0.75	5.95	0.85	7.00	0.94	7.01	1.04	7.03	1.13	7.37	1.32
	8	4.20	0.75	5.11	0.76	5.95	0.86	7.00	0.96	7.01	1.05	7.03	1.15	7.37	1.34
	10	4.20	0.76	5.11	0.78	5.95	0.87	7.00	0.97	7.01	1.07	7.03	1.16	7.37	1.36
	12	4.20	0.77	5.11	0.79	5.95	0.88	7.00	0.98	7.01	1.08	7.03	1.18	7.37	1.38
	14	4.20	0.78	5.11	0.80	5.95	0.90	7.00	1.00	7.01	1.10	7.03	1.20	7.37	1.40
	16	4.20	0.79	5.11	0.81	5.95	0.91	7.00	1.01	7.01	1.11	7.03	1.21	7.37	1.41
	18	4.20	0.80	5.11	0.82	5.95	0.92	7.00	1.02	7.01	1.13	7.03	1.23	7.37	1.43
	20	4.20	0.80	5.11	0.82	5.95	0.93	7.00	1.03	7.01	1.13	7.03	1.24	7.37	1.44
	21	4.20	0.81	5.11	0.83	5.95	0.93	7.00	1.04	7.01	1.14	7.03	1.25	7.37	1.45
	23	4.20	0.81	5.11	0.84	5.95	0.94	7.00	1.04	7.01	1.15	7.03	1.25	7.37	1.46
	25	4.20	0.82	5.11	0.84	5.95	0.95	7.00	1.05	7.01	1.16	7.03	1.26	7.37	1.47
	27	4.20	0.83	5.11	0.85	5.95	0.95	7.00	1.06	7.01	1.16	7.03	1.27	7.37	1.48
	29	4.20	0.84	5.11	0.86	5.95	0.97	7.00	1.08	7.01	1.19	7.03	1.29	7.37	1.51
	31	4.20	0.88	5.11	0.91	5.95	1.02	7.00	1.13	7.01	1.25	7.03	1.30	7.37	1.59
	33	4.20	0.97	5.11	0.99	5.95	1.12	7.00	1.24	7.01	1.37	7.03	1.38	7.37	1.68
35	4.20	1.06	5.11	1.09	5.95	1.23	7.00	1.37	7.01	1.43	7.03	1.52	7.37	1.76	
37	3.95	1.06	4.80	1.09	5.59	1.23	6.58	1.36	6.59	1.43	6.61	1.51	6.93	1.73	
39	3.78	1.10	4.60	1.13	5.36	1.27	6.30	1.41	6.31	1.48	6.33	1.56	6.63	1.79	
41	3.57	1.12	4.34	1.15	5.06	1.29	5.95	1.43	5.96	1.51	5.98	1.59	6.26	1.78	
43	3.36	1.14	4.09	1.17	4.76	1.31	5.60	1.46	5.61	1.53	5.63	1.62	5.90	1.77	
45	3.15	1.21	3.83	1.25	4.46	1.40	5.25	1.56	5.26	1.63	5.27	1.73	5.53	1.87	
48	2.94	1.26	3.58	1.29	4.17	1.45	4.90	1.61	4.91	1.74	4.92	1.79	5.16	1.91	
60%	-5	3.60	0.55	4.38	0.56	5.10	0.63	6.00	0.70	6.01	0.77	6.03	0.84	6.32	0.98
	-2	3.60	0.55	4.38	0.56	5.10	0.64	6.00	0.71	6.01	0.78	6.03	0.85	6.32	0.99
	0	3.60	0.56	4.38	0.57	5.10	0.64	6.00	0.72	6.01	0.79	6.03	0.86	6.32	1.00
	2	3.60	0.57	4.38	0.58	5.10	0.65	6.00	0.73	6.01	0.80	6.03	0.87	6.32	1.02
	4	3.60	0.58	4.38	0.59	5.10	0.66	6.00	0.74	6.01	0.81	6.03	0.89	6.32	1.03
	6	3.60	0.58	4.38	0.60	5.10	0.67	6.00	0.75	6.01	0.82	6.03	0.90	6.32	1.05
	8	3.60	0.59	4.38	0.61	5.10	0.68	6.00	0.76	6.01	0.84	6.03	0.91	6.32	1.06
	10	3.60	0.60	4.38	0.62	5.10	0.69	6.00	0.77	6.01	0.85	6.03	0.93	6.32	1.08
	12	3.60	0.61	4.38	0.63	5.10	0.70	6.00	0.78	6.01	0.86	6.03	0.94	6.32	1.09
	14	3.60	0.62	4.38	0.63	5.10	0.71	6.00	0.79	6.01	0.87	6.03	0.95	6.32	1.11
	16	3.60	0.63	4.38	0.64	5.10	0.72	6.00	0.80	6.01	0.88	6.03	0.96	6.32	1.12
	18	3.60	0.64	4.38	0.65	5.10	0.73	6.00	0.81	6.01	0.90	6.03	0.98	6.32	1.14
	20	3.60	0.64	4.38	0.66	5.10	0.74	6.00	0.82	6.01	0.90	6.03	0.98	6.32	1.15
	21	3.60	0.64	4.38	0.66	5.10	0.74	6.00	0.83	6.01	0.91	6.03	0.99	6.32	1.16
	23	3.60	0.65	4.38	0.66	5.10	0.75	6.00	0.83	6.01	0.91	6.03	1.00	6.32	1.16
	25	3.60	0.65	4.38	0.67	5.10	0.75	6.00	0.84	6.01	0.92	6.03	1.00	6.32	1.17
	27	3.60	0.66	4.38	0.67	5.10	0.76	6.00	0.84	6.01	0.93	6.03	1.01	6.32	1.18
	29	3.60	0.67	4.38	0.69	5.10	0.77	6.00	0.86	6.01	0.94	6.03	1.03	6.32	1.20
	31	3.60	0.70	4.38	0.72	5.10	0.81	6.00	0.90	6.01	0.99	6.03	1.04	6.32	1.26
	33	3.60	0.77	4.38	0.79	5.10	0.89	6.00	0.99	6.01	1.09	6.03	1.10	6.32	1.34
35	3.60	0.85	4.38	0.87	5.10	0.98	6.00	1.09	6.01	1.14	6.03	1.21	6.32	1.40	
37	3.38	0.84	4.12	0.87	4.79	0.97	5.64	1.08	5.65	1.14	5.67	1.20	5.94	1.37	
39	3.24	0.87	3.94	0.89	4.59	1.01	5.40	1.12	5.41	1.17	5.43	1.24	5.69	1.42	
41	3.06	0.89	3.72	0.91	4.34	1.03	5.10	1.14	5.11	1.20	5.12	1.27	5.37	1.42	
43	2.88	0.91	3.50	0.93	4.08	1.05	4.80	1.16	4.81	1.22	4.82	1.29	5.05	1.41	
45	2.70	0.97	3.29	0.99	3.83	1.11	4.50	1.24	4.51	1.30	4.52	1.37	4.74	1.49	
48	2.52	1.00	3.07	1.02	3.57	1.15	4.20	1.28	4.21	1.38	4.22	1.42	4.42	1.52	

Abbreviations:

CR: Combination ratio

TC: Total capacity (kW)

PI: Power input (compressor + outdoor fan motor) (kW)

Notes:

1. Shaded cells indicate rating condition.

Table continued on next page ...

Table 2-8.2: BCSF040NOA6-DTM115 cooling capacity (continued)

CR	Outdoor air temp. (°C DB)	Indoor air temp. (°C DB / °C WB)													
		20.8 / 14.0		23.3 / 16.0		25.8 / 18.0		27.0 / 19.0		28.2 / 20.0		30.7 / 22.0		32.0 / 24.0	
		TC kW	PI kW	TC kW	PI kW	TC kW	PI kW	TC kW	PI kW	TC kW	PI kW	TC kW	PI kW	TC kW	PI kW
50%	-5	3.00	0.43	3.65	0.44	4.25	0.49	5.00	0.55	5.01	0.60	5.02	0.65	5.26	0.76
	-2	3.00	0.43	3.65	0.44	4.25	0.49	5.00	0.55	5.01	0.60	5.02	0.66	5.26	0.77
	0	3.00	0.44	3.65	0.45	4.25	0.50	5.00	0.56	5.01	0.61	5.02	0.67	5.26	0.78
	2	3.00	0.44	3.65	0.45	4.25	0.51	5.00	0.57	5.01	0.62	5.02	0.68	5.26	0.79
	4	3.00	0.45	3.65	0.46	4.25	0.52	5.00	0.58	5.01	0.63	5.02	0.69	5.26	0.81
	6	3.00	0.46	3.65	0.47	4.25	0.53	5.00	0.58	5.01	0.64	5.02	0.70	5.26	0.82
	8	3.00	0.46	3.65	0.47	4.25	0.53	5.00	0.59	5.01	0.65	5.02	0.71	5.26	0.83
	10	3.00	0.47	3.65	0.48	4.25	0.54	5.00	0.60	5.01	0.66	5.02	0.72	5.26	0.84
	12	3.00	0.48	3.65	0.49	4.25	0.55	5.00	0.61	5.01	0.67	5.02	0.73	5.26	0.85
	14	3.00	0.48	3.65	0.49	4.25	0.56	5.00	0.62	5.01	0.68	5.02	0.74	5.26	0.86
	16	3.00	0.49	3.65	0.50	4.25	0.56	5.00	0.63	5.01	0.69	5.02	0.75	5.26	0.88
	18	3.00	0.49	3.65	0.51	4.25	0.57	5.00	0.63	5.01	0.70	5.02	0.76	5.26	0.89
	20	3.00	0.50	3.65	0.51	4.25	0.57	5.00	0.64	5.01	0.70	5.02	0.77	5.26	0.89
	21	3.00	0.50	3.65	0.51	4.25	0.58	5.00	0.64	5.01	0.71	5.02	0.77	5.26	0.90
	23	3.00	0.50	3.65	0.52	4.25	0.58	5.00	0.65	5.01	0.71	5.02	0.78	5.26	0.91
	25	3.00	0.51	3.65	0.52	4.25	0.59	5.00	0.65	5.01	0.72	5.02	0.78	5.26	0.91
	27	3.00	0.51	3.65	0.52	4.25	0.59	5.00	0.66	5.01	0.72	5.02	0.79	5.26	0.92
	29	3.00	0.52	3.65	0.53	4.25	0.60	5.00	0.67	5.01	0.74	5.02	0.80	5.26	0.94
	31	3.00	0.55	3.65	0.56	4.25	0.63	5.00	0.70	5.01	0.77	5.02	0.81	5.26	0.98
	33	3.00	0.60	3.65	0.62	4.25	0.69	5.00	0.77	5.01	0.85	5.02	0.85	5.26	1.04
35	3.00	0.66	3.65	0.68	4.25	0.76	5.00	0.85	5.01	0.89	5.02	0.94	5.26	1.09	
37	2.82	0.66	3.43	0.68	4.00	0.76	4.70	0.84	4.71	0.89	4.72	0.94	4.95	1.07	
39	2.70	0.68	3.29	0.70	3.83	0.78	4.50	0.87	4.51	0.91	4.52	0.97	4.74	1.11	
41	2.55	0.69	3.10	0.71	3.61	0.80	4.25	0.89	4.26	0.93	4.27	0.99	4.47	1.10	
43	2.40	0.71	2.92	0.72	3.40	0.81	4.00	0.91	4.01	0.95	4.02	1.00	4.21	1.10	
45	2.25	0.75	2.74	0.77	3.19	0.87	3.75	0.96	3.76	1.01	3.77	1.07	3.95	1.16	
48	2.10	0.78	2.56	0.80	2.98	0.90	3.50	1.00	3.51	1.08	3.52	1.11	3.68	1.18	

Abbreviations:

CR: Combination ratio

TC: Total capacity (kW)

PI: Power input (compressor + outdoor fan motor) (kW)

Notes:

1. Shaded cells indicate rating condition.

Table 2-8.3: BCSF050N0A7-DTM140 cooling capacity

CR	Outdoor air temp. (°C DB)	Indoor air temp. (°C DB / °C WB)													
		20.8 / 14.0		23.3 / 16.0		25.8 / 18.0		27.0 / 19.0		28.2 / 20.0		30.7 / 22.0		32.0 / 24.0	
		TC kW	PI kW	TC kW	PI kW	TC kW	PI kW	TC kW	PI kW	TC kW	PI kW	TC kW	PI kW	TC kW	PI kW
130%	-5	9.36	2.13	10.92	2.18	13.26	2.46	15.60	2.73	16.07	3.00	16.38	3.27	16.85	3.82
	-2	9.36	2.18	10.92	2.23	13.26	2.51	15.60	2.79	16.07	3.07	16.38	3.35	16.85	3.91
	0	9.36	2.18	10.92	2.23	13.26	2.51	15.60	2.79	16.07	3.07	16.38	3.35	16.85	3.91
	2	9.36	2.18	10.92	2.23	13.26	2.51	15.60	2.79	16.07	3.07	16.38	3.35	16.85	3.91
	4	9.36	2.22	10.92	2.28	13.26	2.57	15.60	2.85	16.07	3.14	16.38	3.42	16.85	3.99
	6	9.36	2.22	10.92	2.28	13.26	2.57	15.60	2.85	16.07	3.14	16.38	3.42	16.85	3.99
	8	9.36	2.22	10.92	2.28	13.26	2.57	15.60	2.85	16.07	3.14	16.38	3.42	16.85	3.99
	10	9.36	2.27	10.92	2.33	13.26	2.62	15.60	2.91	16.07	3.21	16.38	3.50	16.85	4.08
	12	9.36	2.32	10.92	2.38	13.26	2.68	15.60	2.98	16.07	3.27	16.38	3.57	16.85	4.17
	14	9.36	2.37	10.92	2.43	13.26	2.73	15.60	3.04	16.07	3.34	16.38	3.65	16.85	4.25
	16	9.36	2.47	10.92	2.53	13.26	2.85	15.60	3.16	16.07	3.48	16.38	3.80	16.85	4.43
	18	9.36	2.56	10.92	2.63	13.26	2.96	15.60	3.29	16.07	3.62	16.38	3.94	16.85	4.60
	20	9.36	2.81	10.92	2.88	13.26	3.24	15.60	3.60	16.07	3.96	16.38	4.32	16.85	5.04
	21	9.36	2.95	10.92	3.03	13.26	3.40	15.60	3.78	16.07	4.16	16.38	4.54	16.85	5.30
	23	9.36	3.10	10.92	3.17	13.26	3.57	15.60	3.97	16.07	4.37	16.38	4.76	16.85	5.39
	25	9.36	3.24	10.92	3.32	13.26	3.74	15.60	4.15	16.07	4.57	16.38	4.99	16.85	5.41
	27	9.36	3.39	10.92	3.47	13.26	3.91	15.60	4.34	16.07	4.77	16.38	5.21	16.85	5.59
	29	9.36	3.48	10.92	3.57	13.26	4.02	15.60	4.46	16.07	4.91	16.38	5.36	16.85	5.63
	31	9.36	3.47	10.92	3.60	13.26	4.08	15.60	4.53	16.07	4.98	16.38	5.21	16.85	5.70
	33	9.36	3.58	10.92	3.68	13.26	4.18	15.60	4.59	16.07	5.05	16.38	5.09	16.85	5.59
35	9.36	3.64	10.92	3.74	13.26	4.26	15.60	4.77	16.07	5.01	16.38	5.15	16.85	5.81	
37	7.49	3.63	8.74	3.73	10.61	4.33	12.48	4.76	12.50	5.51	12.54	5.14	13.14	5.88	
39	7.02	3.76	8.19	3.87	9.95	4.46	11.70	5.24	11.72	5.85	11.77	5.82	12.32	6.16	
41	6.55	3.90	7.64	4.02	9.28	4.60	10.92	5.57	10.39	6.09	10.48	6.16	11.50	6.16	
43	6.08	4.03	7.10	4.16	8.62	4.75	10.14	5.80	9.65	6.16	10.19	6.16	10.21	6.16	
45	5.62	4.14	6.55	4.25	7.96	4.96	9.36	6.03	8.91	6.16	9.40	6.16	9.45	6.16	
48	5.15	4.24	6.01	4.38	7.29	5.07	8.58	6.16	8.59	6.16	8.62	6.16	8.64	6.16	
120%	-5	8.64	1.91	10.51	1.96	12.24	2.21	14.40	2.45	14.43	2.70	14.47	2.94	15.16	3.43
	-2	8.64	1.95	10.51	2.00	12.24	2.26	14.40	2.51	14.43	2.76	14.47	3.01	15.16	3.51
	0	8.64	1.95	10.51	2.00	12.24	2.26	14.40	2.51	14.43	2.76	14.47	3.01	15.16	3.51
	2	8.64	1.95	10.51	2.00	12.24	2.26	14.40	2.51	14.43	2.76	14.47	3.01	15.16	3.51
	4	8.64	2.00	10.51	2.05	12.24	2.31	14.40	2.56	14.43	2.82	14.47	3.07	15.16	3.59
	6	8.64	2.00	10.51	2.05	12.24	2.31	14.40	2.56	14.43	2.82	14.47	3.07	15.16	3.59
	8	8.64	2.00	10.51	2.05	12.24	2.31	14.40	2.56	14.43	2.82	14.47	3.07	15.16	3.59
	10	8.64	2.04	10.51	2.09	12.24	2.36	14.40	2.62	14.43	2.88	14.47	3.14	15.16	3.66
	12	8.64	2.08	10.51	2.14	12.24	2.41	14.40	2.67	14.43	2.94	14.47	3.21	15.16	3.74
	14	8.64	2.13	10.51	2.18	12.24	2.46	14.40	2.73	14.43	3.00	14.47	3.27	15.16	3.82
	16	8.64	2.22	10.51	2.27	12.24	2.56	14.40	2.84	14.43	3.12	14.47	3.41	15.16	3.98
	18	8.64	2.30	10.51	2.36	12.24	2.66	14.40	2.95	14.43	3.25	14.47	3.54	15.16	4.13
	20	8.64	2.52	10.51	2.58	12.24	2.91	14.40	3.23	14.43	3.55	14.47	3.88	15.16	4.52
	21	8.64	2.65	10.51	2.72	12.24	3.06	14.40	3.40	14.43	3.74	14.47	4.08	15.16	4.76
	23	8.64	2.78	10.51	2.85	12.24	3.21	14.40	3.56	14.43	3.92	14.47	4.28	15.16	4.99
	25	8.64	2.91	10.51	2.98	12.24	3.36	14.40	3.73	14.43	4.10	14.47	4.48	15.16	5.22
	27	8.64	3.17	10.51	3.25	12.24	3.66	14.40	4.07	14.43	4.47	14.47	4.88	15.16	5.69
	29	8.64	3.39	10.51	3.47	12.24	3.91	14.40	4.34	14.43	4.57	14.47	4.98	15.16	6.08
	31	8.64	3.47	10.51	3.56	12.24	4.01	14.40	4.46	14.43	4.68	14.47	5.01	15.16	6.16
	33	8.64	3.56	10.51	3.65	12.24	4.11	14.40	4.57	14.43	4.70	14.47	5.07	14.96	6.16
35	8.64	3.62	10.51	3.71	12.24	4.18	14.40	4.64	14.43	4.81	14.47	5.15	14.72	6.16	
37	8.12	3.61	9.88	3.70	11.51	4.27	13.54	4.63	13.56	4.92	13.60	5.14	14.55	6.16	
39	7.78	3.74	9.46	3.84	11.02	4.40	12.96	4.74	12.98	5.03	13.02	5.34	13.64	6.16	
41	7.34	3.88	8.94	3.99	10.40	4.52	12.24	4.88	12.26	5.15	12.30	5.55	12.89	6.16	
43	6.91	4.01	8.41	4.13	9.79	4.67	11.52	5.01	11.54	5.31	11.57	5.76	12.13	6.16	
45	6.48	4.12	7.88	4.22	9.18	4.87	10.80	5.22	10.82	5.76	10.85	5.90	11.37	6.16	
48	6.05	4.22	7.36	4.35	8.57	4.98	10.08	5.51	10.10	5.92	10.13	6.01	10.61	6.16	

Abbreviations:

CR: Combination ratio

TC: Total capacity (kW)

PI: Power input (compressor + outdoor fan motor) (kW)

Notes:

1. Shaded cells indicate rating condition.

Table continued on next page ...

Table 2-8.3: BCSF050N0A7-DTM140 cooling capacity (continued)

CR	Outdoor air temp. (°C DB)	Indoor air temp. (°C DB / °C WB)													
		20.8 / 14.0		23.3 / 16.0		25.8 / 18.0		27.0 / 19.0		28.2 / 20.0		30.7 / 22.0		32.0 / 24.0	
		TC kW	PI kW	TC kW	PI kW	TC kW	PI kW	TC kW	PI kW	TC kW	PI kW	TC kW	PI kW	TC kW	PI kW
110%	-5	7.92	1.72	9.64	1.76	11.22	1.99	13.20	2.21	13.22	2.43	13.26	2.65	13.90	3.09
	-2	7.92	1.75	9.64	1.80	11.22	2.02	13.20	2.25	13.22	2.47	13.26	2.70	13.90	3.15
	0	7.92	1.79	9.64	1.83	11.22	2.06	13.20	2.29	13.22	2.52	13.26	2.75	13.90	3.21
	2	7.92	1.82	9.64	1.87	11.22	2.10	13.20	2.34	13.22	2.57	13.26	2.80	13.90	3.27
	4	7.92	1.86	9.64	1.90	11.22	2.14	13.20	2.38	13.22	2.62	13.26	2.85	13.90	3.33
	6	7.92	1.89	9.64	1.94	11.22	2.18	13.20	2.42	13.22	2.66	13.26	2.91	13.90	3.39
	8	7.92	1.92	9.64	1.97	11.22	2.22	13.20	2.47	13.22	2.71	13.26	2.96	13.90	3.45
	10	7.92	1.96	9.64	2.01	11.22	2.26	13.20	2.51	13.22	2.76	13.26	3.01	13.90	3.51
	12	7.92	1.99	9.64	2.04	11.22	2.30	13.20	2.55	13.22	2.81	13.26	3.06	13.90	3.57
	14	7.92	2.02	9.64	2.08	11.22	2.34	13.20	2.60	13.22	2.85	13.26	3.11	13.90	3.63
	16	7.92	2.06	9.64	2.11	11.22	2.37	13.20	2.64	13.22	2.90	13.26	3.17	13.90	3.69
	18	7.92	2.13	9.64	2.18	11.22	2.45	13.20	2.72	13.22	3.00	13.26	3.27	13.90	3.81
	20	7.92	2.29	9.64	2.35	11.22	2.65	13.20	2.94	13.22	3.24	13.26	3.53	13.90	4.12
	21	7.92	2.40	9.64	2.46	11.22	2.76	13.20	3.07	13.22	3.38	13.26	3.69	13.90	4.30
	23	7.92	2.50	9.64	2.56	11.22	2.88	13.20	3.20	13.22	3.52	13.26	3.84	13.90	4.48
	25	7.92	2.60	9.64	2.66	11.22	3.00	13.20	3.33	13.22	3.66	13.26	4.00	13.90	4.66
	27	7.92	2.67	9.64	2.73	11.22	3.08	13.20	3.42	13.22	3.76	13.26	4.10	13.90	4.78
	29	7.92	2.73	9.64	2.80	11.22	3.15	13.20	3.50	13.22	3.85	13.26	4.20	13.90	4.90
	31	7.92	2.87	9.64	2.94	11.22	3.31	13.20	3.68	13.22	4.04	13.26	4.23	13.90	5.15
	33	7.92	2.94	9.64	3.01	11.22	3.39	13.20	3.76	13.22	4.14	13.26	4.18	13.90	5.09
35	7.92	3.07	9.64	3.15	11.22	3.54	13.20	3.93	13.22	4.13	13.26	4.36	13.90	5.06	
37	7.44	3.06	9.06	3.14	10.55	3.53	12.41	3.92	12.43	4.12	12.47	4.35	13.06	4.98	
39	7.13	3.47	8.67	3.55	10.10	4.00	11.88	4.44	11.90	4.67	11.94	4.93	12.51	5.52	
41	6.73	3.68	8.19	3.77	9.54	4.25	11.22	4.72	11.24	4.95	11.27	5.24	11.81	5.67	
43	6.34	3.83	7.71	3.93	8.98	4.42	10.56	4.92	10.58	5.16	10.61	5.46	11.12	5.77	
45	5.94	3.99	7.23	4.09	8.42	4.60	9.90	5.11	9.92	5.37	9.95	5.67	10.42	5.93	
48	5.54	4.17	6.75	4.28	7.85	4.81	9.24	5.35	9.26	5.78	9.28	5.83	9.73	6.01	
100%	-5	7.20	1.51	8.76	1.55	10.20	1.75	12.00	1.94	12.02	2.13	12.06	2.33	12.63	2.72
	-2	7.20	1.54	8.76	1.58	10.20	1.77	12.00	1.97	12.02	2.17	12.06	2.37	12.63	2.76
	0	7.20	1.56	8.76	1.60	10.20	1.80	12.00	2.00	12.02	2.20	12.06	2.40	12.63	2.80
	2	7.20	1.59	8.76	1.63	10.20	1.83	12.00	2.04	12.02	2.24	12.06	2.44	12.63	2.85
	4	7.20	1.61	8.76	1.65	10.20	1.86	12.00	2.07	12.02	2.27	12.06	2.48	12.63	2.89
	6	7.20	1.64	8.76	1.68	10.20	1.89	12.00	2.10	12.02	2.31	12.06	2.52	12.63	2.94
	8	7.20	1.66	8.76	1.70	10.20	1.92	12.00	2.13	12.02	2.34	12.06	2.56	12.63	2.98
	10	7.20	1.69	8.76	1.73	10.20	1.95	12.00	2.16	12.02	2.38	12.06	2.59	12.63	3.03
	12	7.20	1.71	8.76	1.76	10.20	1.97	12.00	2.19	12.02	2.41	12.06	2.63	12.63	3.07
	14	7.20	1.74	8.76	1.78	10.20	2.00	12.00	2.23	12.02	2.45	12.06	2.67	12.63	3.12
	16	7.20	1.76	8.76	1.81	10.20	2.03	12.00	2.26	12.02	2.48	12.06	2.71	12.63	3.16
	18	7.20	1.79	8.76	1.83	10.20	2.06	12.00	2.29	12.02	2.52	12.06	2.75	12.63	3.21
	20	7.20	1.81	8.76	1.86	10.20	2.09	12.00	2.32	12.02	2.55	12.06	2.79	12.63	3.25
	21	7.20	1.84	8.76	1.88	10.20	2.12	12.00	2.35	12.02	2.59	12.06	2.82	12.63	3.29
	23	7.20	1.86	8.76	1.91	10.20	2.15	12.00	2.39	12.02	2.62	12.06	2.86	12.63	3.34
	25	7.20	1.89	8.76	1.93	10.20	2.18	12.00	2.42	12.02	2.66	12.06	2.90	12.63	3.38
	27	7.20	1.91	8.76	1.96	10.20	2.20	12.00	2.45	12.02	2.69	12.06	2.94	12.63	3.43
	29	7.20	1.96	8.76	2.01	10.20	2.26	12.00	2.51	12.02	2.76	12.06	3.01	12.63	3.52
	31	7.20	2.06	8.76	2.11	10.20	2.38	12.00	2.64	12.02	2.90	12.06	3.04	12.63	3.70
	33	7.20	2.26	8.76	2.32	10.20	2.60	12.00	2.89	12.02	3.18	12.06	3.21	12.63	3.91
35	7.20	2.48	8.76	2.54	10.20	2.86	12.00	3.18	12.02	3.34	12.06	3.53	12.63	4.10	
37	6.77	2.47	8.23	2.54	9.59	2.85	11.28	3.17	11.30	3.33	11.33	3.52	11.88	4.03	
39	6.48	2.80	7.88	2.87	9.18	3.23	10.80	3.59	10.82	3.77	10.85	3.99	11.37	4.56	
41	6.12	2.98	7.45	3.05	8.67	3.43	10.20	3.82	10.22	4.01	10.25	4.24	10.74	4.74	
43	5.76	3.10	7.01	3.18	8.16	3.58	9.60	3.98	9.62	4.17	9.64	4.41	10.11	4.83	
45	5.40	3.22	6.57	3.31	7.65	3.72	9.00	4.13	9.02	4.34	9.04	4.59	9.48	4.96	
48	5.04	3.37	6.13	3.46	7.14	3.89	8.40	4.32	8.41	4.67	8.44	4.80	8.84	5.13	

Abbreviations:

CR: Combination ratio

TC: Total capacity (kW)

PI: Power input (compressor + outdoor fan motor) (kW)

Notes:

1. Shaded cells indicate rating condition.

Table continued on next page ...

Table 2-8.3: BCSF050N0A7-DTM140 cooling capacity (continued)

CR	Outdoor air temp. (°C DB)	Indoor air temp. (°C DB / °C WB)													
		20.8 / 14.0		23.3 / 16.0		25.8 / 18.0		27.0 / 19.0		28.2 / 20.0		30.7 / 22.0		32.0 / 24.0	
		TC kW	PI kW	TC kW	PI kW	TC kW	PI kW	TC kW	PI kW	TC kW	PI kW	TC kW	PI kW	TC kW	PI kW
90%	-5	6.48	1.31	7.88	1.34	9.18	1.51	10.80	1.68	10.82	1.84	10.85	2.01	11.37	2.35
	-2	6.48	1.33	7.88	1.36	9.18	1.53	10.80	1.70	10.82	1.87	10.85	2.04	11.37	2.38
	0	6.48	1.35	7.88	1.38	9.18	1.56	10.80	1.73	10.82	1.90	10.85	2.08	11.37	2.42
	2	6.48	1.37	7.88	1.41	9.18	1.58	10.80	1.76	10.82	1.93	10.85	2.11	11.37	2.46
	4	6.48	1.39	7.88	1.43	9.18	1.61	10.80	1.79	10.82	1.96	10.85	2.14	11.37	2.50
	6	6.48	1.41	7.88	1.45	9.18	1.63	10.80	1.81	10.82	1.99	10.85	2.18	11.37	2.54
	8	6.48	1.44	7.88	1.47	9.18	1.66	10.80	1.84	10.82	2.02	10.85	2.21	11.37	2.58
	10	6.48	1.46	7.88	1.49	9.18	1.68	10.80	1.87	10.82	2.06	10.85	2.24	11.37	2.62
	12	6.48	1.48	7.88	1.52	9.18	1.71	10.80	1.90	10.82	2.09	10.85	2.27	11.37	2.65
	14	6.48	1.50	7.88	1.54	9.18	1.73	10.80	1.92	10.82	2.12	10.85	2.31	11.37	2.69
	16	6.48	1.52	7.88	1.56	9.18	1.76	10.80	1.95	10.82	2.15	10.85	2.34	11.37	2.73
	18	6.48	1.54	7.88	1.58	9.18	1.78	10.80	1.98	10.82	2.18	10.85	2.37	11.37	2.77
	20	6.48	1.56	7.88	1.60	9.18	1.81	10.80	2.01	10.82	2.21	10.85	2.41	11.37	2.81
	21	6.48	1.59	7.88	1.63	9.18	1.83	10.80	2.03	10.82	2.24	10.85	2.44	11.37	2.85
	23	6.48	1.61	7.88	1.65	9.18	1.85	10.80	2.06	10.82	2.27	10.85	2.47	11.37	2.88
	25	6.48	1.63	7.88	1.67	9.18	1.88	10.80	2.09	10.82	2.30	10.85	2.51	11.37	2.92
	27	6.48	1.65	7.88	1.69	9.18	1.90	10.80	2.12	10.82	2.33	10.85	2.54	11.37	2.96
	29	6.48	1.69	7.88	1.74	9.18	1.95	10.80	2.17	10.82	2.39	10.85	2.60	11.37	3.04
	31	6.48	1.78	7.88	1.82	9.18	2.05	10.80	2.28	10.82	2.51	10.85	2.62	11.37	3.19
	33	6.48	1.95	7.88	2.00	9.18	2.25	10.80	2.50	10.82	2.75	10.85	2.78	11.37	3.38
35	6.48	2.14	7.88	2.20	9.18	2.47	10.80	2.75	10.82	2.88	10.85	3.05	11.37	3.54	
37	6.09	2.14	7.41	2.19	8.63	2.47	10.15	2.74	10.17	2.88	10.20	3.04	10.69	3.48	
39	5.83	2.21	7.10	2.26	8.26	2.55	9.72	2.83	9.74	2.97	9.77	3.14	10.23	3.59	
41	5.51	2.25	6.70	2.31	7.80	2.60	9.18	2.88	9.20	3.03	9.22	3.20	9.66	3.58	
43	5.18	2.29	6.31	2.35	7.34	2.65	8.64	2.94	8.66	3.09	8.68	3.26	9.10	3.57	
45	4.86	2.44	5.91	2.51	6.89	2.82	8.10	3.13	8.11	3.29	8.14	3.48	8.53	3.76	
48	4.54	2.53	5.52	2.59	6.43	2.92	7.56	3.24	7.57	3.50	7.60	3.60	7.96	3.85	
80%	-5	5.76	1.08	7.01	1.10	8.16	1.24	9.60	1.38	9.62	1.52	9.64	1.66	10.11	1.93
	-2	5.76	1.09	7.01	1.12	8.16	1.26	9.60	1.40	9.62	1.54	9.64	1.68	10.11	1.97
	0	5.76	1.11	7.01	1.14	8.16	1.28	9.60	1.43	9.62	1.57	9.64	1.71	10.11	2.00
	2	5.76	1.13	7.01	1.16	8.16	1.30	9.60	1.45	9.62	1.59	9.64	1.74	10.11	2.03
	4	5.76	1.15	7.01	1.18	8.16	1.32	9.60	1.47	9.62	1.62	9.64	1.77	10.11	2.06
	6	5.76	1.17	7.01	1.20	8.16	1.34	9.60	1.49	9.62	1.64	9.64	1.79	10.11	2.09
	8	5.76	1.18	7.01	1.21	8.16	1.37	9.60	1.52	9.62	1.67	9.64	1.82	10.11	2.12
	10	5.76	1.20	7.01	1.23	8.16	1.39	9.60	1.54	9.62	1.69	9.64	1.85	10.11	2.16
	12	5.76	1.22	7.01	1.25	8.16	1.41	9.60	1.56	9.62	1.72	9.64	1.87	10.11	2.19
	14	5.76	1.24	7.01	1.27	8.16	1.43	9.60	1.58	9.62	1.74	9.64	1.90	10.11	2.22
	16	5.76	1.25	7.01	1.29	8.16	1.45	9.60	1.61	9.62	1.77	9.64	1.93	10.11	2.25
	18	5.76	1.27	7.01	1.30	8.16	1.47	9.60	1.63	9.62	1.79	9.64	1.96	10.11	2.28
	20	5.76	1.29	7.01	1.32	8.16	1.49	9.60	1.65	9.62	1.82	9.64	1.98	10.11	2.31
	21	5.76	1.31	7.01	1.34	8.16	1.51	9.60	1.68	9.62	1.84	9.64	2.01	10.11	2.35
	23	5.76	1.32	7.01	1.36	8.16	1.53	9.60	1.70	9.62	1.87	9.64	2.04	10.11	2.38
	25	5.76	1.34	7.01	1.38	8.16	1.55	9.60	1.72	9.62	1.89	9.64	2.06	10.11	2.41
	27	5.76	1.36	7.01	1.39	8.16	1.57	9.60	1.74	9.62	1.92	9.64	2.09	10.11	2.44
	29	5.76	1.40	7.01	1.43	8.16	1.61	9.60	1.79	9.62	1.97	9.64	2.15	10.11	2.50
	31	5.76	1.47	7.01	1.50	8.16	1.69	9.60	1.88	9.62	2.07	9.64	2.16	10.11	2.63
	33	5.76	1.61	7.01	1.65	8.16	1.85	9.60	2.06	9.62	2.27	9.64	2.29	10.11	2.79
35	5.76	1.77	7.01	1.81	8.16	2.04	9.60	2.26	9.62	2.38	9.64	2.51	10.11	2.92	
37	5.41	1.76	6.59	1.81	7.67	2.03	9.02	2.26	9.04	2.37	9.07	2.51	9.50	2.87	
39	5.18	1.82	6.31	1.87	7.34	2.10	8.64	2.33	8.66	2.45	8.68	2.59	9.10	2.96	
41	4.90	1.85	5.96	1.90	6.94	2.14	8.16	2.38	8.17	2.50	8.20	2.64	8.59	2.95	
43	4.61	1.89	5.61	1.94	6.53	2.18	7.68	2.42	7.69	2.54	7.72	2.69	8.09	2.94	
45	4.32	2.01	5.26	2.06	6.12	2.32	7.20	2.58	7.21	2.71	7.23	2.87	7.58	3.10	
48	4.03	2.08	4.91	2.14	5.71	2.40	6.72	2.67	6.73	2.89	6.75	2.97	7.07	3.17	

Abbreviations:

CR: Combination ratio

TC: Total capacity (kW)

PI: Power input (compressor + outdoor fan motor) (kW)

Notes:

1. Shaded cells indicate rating condition.

Table continued on next page ...

Table 2-8.3: BCSF050N0A7-DTM140 cooling capacity (continued)

CR	Outdoor air temp. (°C DB)	Indoor air temp. (°C DB / °C WB)													
		20.8 / 14.0		23.3 / 16.0		25.8 / 18.0		27.0 / 19.0		28.2 / 20.0		30.7 / 22.0		32.0 / 24.0	
		TC kW	PI kW	TC kW	PI kW	TC kW	PI kW	TC kW	PI kW	TC kW	PI kW	TC kW	PI kW	TC kW	PI kW
70%	-5	5.04	0.93	6.13	0.95	7.14	1.07	8.40	1.19	8.41	1.31	8.44	1.43	8.84	1.67
	-2	5.04	0.94	6.13	0.96	7.14	1.08	8.40	1.20	8.41	1.32	8.44	1.44	8.84	1.68
	0	5.04	0.95	6.13	0.98	7.14	1.10	8.40	1.22	8.41	1.34	8.44	1.46	8.84	1.71
	2	5.04	0.97	6.13	0.99	7.14	1.11	8.40	1.24	8.41	1.36	8.44	1.49	8.84	1.73
	4	5.04	0.98	6.13	1.01	7.14	1.13	8.40	1.26	8.41	1.38	8.44	1.51	8.84	1.76
	6	5.04	0.99	6.13	1.02	7.14	1.15	8.40	1.27	8.41	1.40	8.44	1.53	8.84	1.78
	8	5.04	1.01	6.13	1.03	7.14	1.16	8.40	1.29	8.41	1.42	8.44	1.55	8.84	1.81
	10	5.04	1.02	6.13	1.05	7.14	1.18	8.40	1.31	8.41	1.44	8.44	1.57	8.84	1.84
	12	5.04	1.04	6.13	1.06	7.14	1.20	8.40	1.33	8.41	1.46	8.44	1.60	8.84	1.86
	14	5.04	1.05	6.13	1.08	7.14	1.21	8.40	1.35	8.41	1.48	8.44	1.62	8.84	1.89
	16	5.04	1.07	6.13	1.09	7.14	1.23	8.40	1.37	8.41	1.50	8.44	1.64	8.84	1.91
	18	5.04	1.08	6.13	1.11	7.14	1.25	8.40	1.39	8.41	1.52	8.44	1.66	8.84	1.94
	20	5.04	1.09	6.13	1.12	7.14	1.26	8.40	1.39	8.41	1.53	8.44	1.67	8.84	1.95
	21	5.04	1.10	6.13	1.12	7.14	1.26	8.40	1.40	8.41	1.54	8.44	1.68	8.84	1.97
	23	5.04	1.10	6.13	1.13	7.14	1.27	8.40	1.41	8.41	1.55	8.44	1.70	8.84	1.98
	25	5.04	1.11	6.13	1.14	7.14	1.28	8.40	1.42	8.41	1.56	8.44	1.71	8.84	1.99
	27	5.04	1.12	6.13	1.15	7.14	1.29	8.40	1.43	8.41	1.58	8.44	1.72	8.84	2.00
	29	5.04	1.14	6.13	1.17	7.14	1.31	8.40	1.46	8.41	1.61	8.44	1.75	8.84	2.04
	31	5.04	1.20	6.13	1.23	7.14	1.38	8.40	1.53	8.41	1.69	8.44	1.76	8.84	2.15
	33	5.04	1.31	6.13	1.35	7.14	1.51	8.40	1.68	8.41	1.85	8.44	1.87	8.84	2.27
35	5.04	1.44	6.13	1.48	7.14	1.66	8.40	1.85	8.41	1.94	8.44	2.05	8.84	2.38	
37	4.74	1.44	5.76	1.47	6.71	1.66	7.90	1.84	7.91	1.94	7.93	2.05	8.31	2.34	
39	4.54	1.48	5.52	1.52	6.43	1.71	7.56	1.90	7.57	2.00	7.60	2.11	7.96	2.42	
41	4.28	1.51	5.21	1.55	6.07	1.75	7.14	1.94	7.15	2.04	7.17	2.15	7.52	2.41	
43	4.03	1.54	4.91	1.58	5.71	1.78	6.72	1.98	6.73	2.08	6.75	2.19	7.07	2.40	
45	3.78	1.64	4.60	1.68	5.36	1.90	6.30	2.11	6.31	2.21	6.33	2.34	6.63	2.53	
48	3.53	1.70	4.29	1.74	5.00	1.96	5.88	2.18	5.89	2.35	5.91	2.42	6.19	2.59	
60%	-5	4.32	0.74	5.26	0.76	6.12	0.85	7.20	0.95	7.21	1.04	7.23	1.14	7.58	1.33
	-2	4.32	0.74	5.26	0.76	6.12	0.86	7.20	0.95	7.21	1.05	7.23	1.15	7.58	1.34
	0	4.32	0.76	5.26	0.78	6.12	0.87	7.20	0.97	7.21	1.07	7.23	1.16	7.58	1.36
	2	4.32	0.77	5.26	0.79	6.12	0.89	7.20	0.98	7.21	1.08	7.23	1.18	7.58	1.38
	4	4.32	0.78	5.26	0.80	6.12	0.90	7.20	1.00	7.21	1.10	7.23	1.20	7.58	1.40
	6	4.32	0.79	5.26	0.81	6.12	0.91	7.20	1.01	7.21	1.12	7.23	1.22	7.58	1.42
	8	4.32	0.80	5.26	0.82	6.12	0.93	7.20	1.03	7.21	1.13	7.23	1.23	7.58	1.44
	10	4.32	0.81	5.26	0.83	6.12	0.94	7.20	1.04	7.21	1.15	7.23	1.25	7.58	1.46
	12	4.32	0.83	5.26	0.85	6.12	0.95	7.20	1.06	7.21	1.16	7.23	1.27	7.58	1.48
	14	4.32	0.84	5.26	0.86	6.12	0.97	7.20	1.07	7.21	1.18	7.23	1.29	7.58	1.50
	16	4.32	0.85	5.26	0.87	6.12	0.98	7.20	1.09	7.21	1.20	7.23	1.30	7.58	1.52
	18	4.32	0.86	5.26	0.88	6.12	0.99	7.20	1.10	7.21	1.21	7.23	1.32	7.58	1.54
	20	4.32	0.87	5.26	0.89	6.12	1.00	7.20	1.11	7.21	1.22	7.23	1.33	7.58	1.55
	21	4.32	0.87	5.26	0.89	6.12	1.00	7.20	1.12	7.21	1.23	7.23	1.34	7.58	1.56
	23	4.32	0.88	5.26	0.90	6.12	1.01	7.20	1.12	7.21	1.24	7.23	1.35	7.58	1.57
	25	4.32	0.88	5.26	0.91	6.12	1.02	7.20	1.13	7.21	1.24	7.23	1.36	7.58	1.58
	27	4.32	0.89	5.26	0.91	6.12	1.02	7.20	1.14	7.21	1.25	7.23	1.37	7.58	1.59
	29	4.32	0.91	5.26	0.93	6.12	1.04	7.20	1.16	7.21	1.28	7.23	1.39	7.58	1.62
	31	4.32	0.95	5.26	0.98	6.12	1.10	7.20	1.22	7.21	1.34	7.23	1.40	7.58	1.71
	33	4.32	1.04	5.26	1.07	6.12	1.20	7.20	1.34	7.21	1.47	7.23	1.48	7.58	1.81
35	4.32	1.15	5.26	1.18	6.12	1.32	7.20	1.47	7.21	1.54	7.23	1.63	7.58	1.89	
37	4.06	1.14	4.94	1.17	5.75	1.32	6.77	1.47	6.78	1.54	6.80	1.63	7.13	1.86	
39	3.89	1.18	4.73	1.21	5.51	1.36	6.48	1.51	6.49	1.59	6.51	1.68	6.82	1.92	
41	3.67	1.20	4.47	1.23	5.20	1.39	6.12	1.54	6.13	1.62	6.15	1.71	6.44	1.92	
43	3.46	1.23	4.20	1.26	4.90	1.41	5.76	1.57	5.77	1.65	5.79	1.74	6.06	1.91	
45	3.24	1.31	3.94	1.34	4.59	1.51	5.40	1.67	5.41	1.76	5.43	1.86	5.69	2.01	
48	3.02	1.35	3.68	1.39	4.28	1.56	5.04	1.73	5.05	1.87	5.06	1.92	5.31	2.06	

Abbreviations:

CR: Combination ratio

TC: Total capacity (kW)

PI: Power input (compressor + outdoor fan motor) (kW)

Notes:

1. Shaded cells indicate rating condition.

Table continued on next page ...

Table 2-8.3: BCSF050NOA7-DTM140 cooling capacity (continued)

CR	Outdoor air temp. (°C DB)	Indoor air temp. (°C DB / °C WB)													
		20.8 / 14.0		23.3 / 16.0		25.8 / 18.0		27.0 / 19.0		28.2 / 20.0		30.7 / 22.0		32.0 / 24.0	
		TC kW	PI kW	TC kW	PI kW	TC kW	PI kW	TC kW	PI kW	TC kW	PI kW	TC kW	PI kW	TC kW	PI kW
50%	-5	3.60	0.58	4.38	0.59	5.10	0.66	6.00	0.74	6.01	0.81	6.03	0.89	6.32	1.03
	-2	3.60	0.58	4.38	0.60	5.10	0.67	6.00	0.74	6.01	0.82	6.03	0.89	6.32	1.04
	0	3.60	0.59	4.38	0.60	5.10	0.68	6.00	0.76	6.01	0.83	6.03	0.91	6.32	1.06
	2	3.60	0.60	4.38	0.61	5.10	0.69	6.00	0.77	6.01	0.84	6.03	0.92	6.32	1.07
	4	3.60	0.61	4.38	0.62	5.10	0.70	6.00	0.78	6.01	0.86	6.03	0.93	6.32	1.09
	6	3.60	0.62	4.38	0.63	5.10	0.71	6.00	0.79	6.01	0.87	6.03	0.95	6.32	1.11
	8	3.60	0.63	4.38	0.64	5.10	0.72	6.00	0.80	6.01	0.88	6.03	0.96	6.32	1.12
	10	3.60	0.63	4.38	0.65	5.10	0.73	6.00	0.81	6.01	0.89	6.03	0.98	6.32	1.14
	12	3.60	0.64	4.38	0.66	5.10	0.74	6.00	0.82	6.01	0.91	6.03	0.99	6.32	1.15
	14	3.60	0.65	4.38	0.67	5.10	0.75	6.00	0.84	6.01	0.92	6.03	1.00	6.32	1.17
	16	3.60	0.66	4.38	0.68	5.10	0.76	6.00	0.85	6.01	0.93	6.03	1.02	6.32	1.19
	18	3.60	0.67	4.38	0.69	5.10	0.77	6.00	0.86	6.01	0.94	6.03	1.03	6.32	1.20
	20	3.60	0.67	4.38	0.69	5.10	0.78	6.00	0.86	6.01	0.95	6.03	1.04	6.32	1.21
	21	3.60	0.68	4.38	0.70	5.10	0.78	6.00	0.87	6.01	0.96	6.03	1.04	6.32	1.22
	23	3.60	0.68	4.38	0.70	5.10	0.79	6.00	0.88	6.01	0.96	6.03	1.05	6.32	1.23
	25	3.60	0.69	4.38	0.71	5.10	0.79	6.00	0.88	6.01	0.97	6.03	1.06	6.32	1.23
	27	3.60	0.69	4.38	0.71	5.10	0.80	6.00	0.89	6.01	0.98	6.03	1.06	6.32	1.24
	29	3.60	0.71	4.38	0.72	5.10	0.81	6.00	0.90	6.01	0.99	6.03	1.09	6.32	1.27
	31	3.60	0.74	4.38	0.76	5.10	0.86	6.00	0.95	6.01	1.05	6.03	1.09	6.32	1.33
	33	3.60	0.81	4.38	0.83	5.10	0.94	6.00	1.04	6.01	1.15	6.03	1.16	6.32	1.41
35	3.60	0.89	4.38	0.92	5.10	1.03	6.00	1.14	6.01	1.20	6.03	1.27	6.32	1.47	
37	3.38	0.89	4.12	0.91	4.79	1.03	5.64	1.14	5.65	1.20	5.67	1.27	5.94	1.45	
39	3.24	0.92	3.94	0.94	4.59	1.06	5.40	1.18	5.41	1.24	5.43	1.31	5.69	1.50	
41	3.06	0.94	3.72	0.96	4.34	1.08	5.10	1.20	5.11	1.26	5.12	1.33	5.37	1.49	
43	2.88	0.96	3.50	0.98	4.08	1.10	4.80	1.22	4.81	1.29	4.82	1.36	5.05	1.49	
45	2.70	1.02	3.29	1.04	3.83	1.17	4.50	1.31	4.51	1.37	4.52	1.45	4.74	1.57	
48	2.52	1.05	3.07	1.08	3.57	1.22	4.20	1.35	4.21	1.46	4.22	1.50	4.42	1.60	

Abbreviations:

CR: Combination ratio

TC: Total capacity (kW)

PI: Power input (compressor + outdoor fan motor) (kW)

Notes:

1. Shaded cells indicate rating condition.

Table 2-8.4: BCSF060NOA8-DTM160 cooling capacity

CR	Outdoor air temp. (°C DB)	Indoor air temp. (°C DB / °C WB)													
		20.8 / 14.0		23.3 / 16.0		25.8 / 18.0		27.0 / 19.0		28.2 / 20.0		30.7 / 22.0		32.0 / 24.0	
		TC kW	PI kW	TC kW	PI kW	TC kW	PI kW	TC kW	PI kW	TC kW	PI kW	TC kW	PI kW	TC kW	PI kW
130%	-5	10.92	2.37	12.74	2.43	15.47	2.73	18.20	3.04	18.75	3.34	19.11	3.64	19.66	4.25
	-2	10.92	2.42	12.74	2.49	15.47	2.80	18.20	3.11	18.75	3.42	19.11	3.73	19.66	4.35
	0	10.92	2.42	12.74	2.49	15.47	2.80	18.20	3.11	18.75	3.42	19.11	3.73	19.66	4.35
	2	10.92	2.42	12.74	2.49	15.47	2.80	18.20	3.11	18.75	3.42	19.11	3.73	19.66	4.35
	4	10.92	2.48	12.74	2.54	15.47	2.86	18.20	3.18	18.75	3.49	19.11	3.81	19.66	4.45
	6	10.92	2.48	12.74	2.54	15.47	2.86	18.20	3.18	18.75	3.49	19.11	3.81	19.66	4.45
	8	10.92	2.48	12.74	2.54	15.47	2.86	18.20	3.18	18.75	3.49	19.11	3.81	19.66	4.45
	10	10.92	2.53	12.74	2.60	15.47	2.92	18.20	3.24	18.75	3.57	19.11	3.89	19.66	4.54
	12	10.92	2.58	12.74	2.65	15.47	2.98	18.20	3.31	18.75	3.64	19.11	3.98	19.66	4.64
	14	10.92	2.64	12.74	2.71	15.47	3.04	18.20	3.38	18.75	3.72	19.11	4.06	19.66	4.74
	16	10.92	2.75	12.74	2.82	15.47	3.17	18.20	3.52	18.75	3.87	19.11	4.22	19.66	4.93
	18	10.92	2.85	12.74	2.93	15.47	3.29	18.20	3.66	18.75	4.02	19.11	4.39	19.66	5.12
	20	10.92	3.12	12.74	3.20	15.47	3.60	18.20	4.00	18.75	4.40	19.11	4.80	19.66	5.61
	21	10.92	3.28	12.74	3.37	15.47	3.79	18.20	4.21	18.75	4.63	19.11	5.05	19.66	5.90
	23	10.92	3.45	12.74	3.53	15.47	3.98	18.20	4.42	18.75	4.86	19.11	5.30	19.66	6.00
	25	10.92	3.61	12.74	3.70	15.47	4.16	18.20	4.63	18.75	5.09	19.11	5.55	19.66	6.02
	27	10.92	3.77	12.74	3.87	15.47	4.35	18.20	4.83	18.75	5.32	19.11	5.80	19.66	6.21
	29	10.92	3.88	12.74	3.98	15.47	4.47	18.20	4.97	18.75	5.47	19.11	5.96	19.66	6.21
	31	10.92	3.93	12.74	4.03	15.47	4.54	18.20	5.04	18.75	5.54	19.11	5.80	18.78	6.21
	33	10.92	3.98	12.74	4.09	15.47	4.60	18.20	5.11	18.75	5.62	19.11	5.67	18.42	6.21
	35	10.92	4.14	12.74	4.25	15.47	4.78	18.20	5.31	18.75	5.58	19.11	5.15	17.98	6.21
	37	8.74	4.13	10.19	4.24	12.38	4.77	14.56	5.30	14.59	5.51	14.63	5.14	15.33	6.21
	39	8.19	4.21	9.56	4.20	11.60	4.72	13.65	5.24	13.67	5.85	13.73	5.82	14.37	6.21
	41	7.64	4.34	8.92	4.46	10.83	5.01	11.74	5.57	12.12	6.09	12.53	6.18	12.51	6.21
43	7.10	4.52	8.28	4.64	10.06	5.22	11.23	5.80	11.26	6.21	11.88	6.21	11.95	6.21	
45	6.55	4.64	7.64	4.83	9.28	5.43	10.92	6.03	10.39	6.21	10.97	6.21	11.08	6.21	
48	6.01	4.78	7.01	5.05	8.51	5.68	10.01	6.21	10.03	6.21	10.06	6.21	10.14	6.21	
120%	-5	10.08	2.13	12.26	2.18	14.28	2.45	16.80	2.73	16.83	3.00	16.88	3.27	17.69	3.82
	-2	10.08	2.18	12.26	2.23	14.28	2.51	16.80	2.79	16.83	3.07	16.88	3.35	17.69	3.91
	0	10.08	2.18	12.26	2.23	14.28	2.51	16.80	2.79	16.83	3.07	16.88	3.35	17.69	3.91
	2	10.08	2.18	12.26	2.23	14.28	2.51	16.80	2.79	16.83	3.07	16.88	3.35	17.69	3.91
	4	10.08	2.22	12.26	2.28	14.28	2.57	16.80	2.85	16.83	3.14	16.88	3.42	17.69	3.99
	6	10.08	2.22	12.26	2.28	14.28	2.57	16.80	2.85	16.83	3.14	16.88	3.42	17.69	3.99
	8	10.08	2.22	12.26	2.28	14.28	2.57	16.80	2.85	16.83	3.14	16.88	3.42	17.69	3.99
	10	10.08	2.27	12.26	2.33	14.28	2.62	16.80	2.91	16.83	3.20	16.88	3.50	17.69	4.08
	12	10.08	2.32	12.26	2.38	14.28	2.68	16.80	2.98	16.83	3.27	16.88	3.57	17.69	4.17
	14	10.08	2.37	12.26	2.43	14.28	2.73	16.80	3.04	16.83	3.34	16.88	3.65	17.69	4.25
	16	10.08	2.47	12.26	2.53	14.28	2.85	16.80	3.16	16.83	3.48	16.88	3.79	17.69	4.43
	18	10.08	2.56	12.26	2.63	14.28	2.96	16.80	3.29	16.83	3.61	16.88	3.94	17.69	4.60
	20	10.08	2.80	12.26	2.88	14.28	3.24	16.80	3.60	16.83	3.96	16.88	4.31	17.69	5.03
	21	10.08	2.95	12.26	3.03	14.28	3.40	16.80	3.78	16.83	4.16	16.88	4.54	17.69	5.29
	23	10.08	3.09	12.26	3.17	14.28	3.57	16.80	3.97	16.83	4.36	16.88	4.76	17.69	5.55
	25	10.08	3.24	12.26	3.32	14.28	3.74	16.80	4.15	16.83	4.57	16.88	4.98	17.69	5.81
	27	10.08	3.53	12.26	3.62	14.28	4.07	16.80	4.53	16.83	4.98	16.88	5.43	17.69	6.21
	29	10.08	3.77	12.26	3.87	14.28	4.35	16.80	4.84	16.83	5.32	16.88	5.80	17.11	6.21
	31	10.08	3.87	12.26	3.97	14.28	4.46	16.80	4.96	16.83	5.46	16.88	5.70	16.86	6.21
	33	10.08	3.97	12.26	4.07	14.28	4.58	16.80	5.08	16.83	5.59	16.88	5.64	16.75	6.21
	35	10.08	4.03	12.26	4.13	14.28	4.65	16.80	5.17	16.83	5.42	16.88	5.73	16.69	6.21
	37	9.48	4.02	11.53	4.12	13.42	4.64	15.79	5.15	15.82	5.41	15.87	5.72	16.63	6.21
	39	9.07	4.55	11.04	4.67	12.85	5.25	15.12	5.84	15.15	6.13	15.19	6.21	15.92	6.21
	41	8.57	4.84	10.42	4.96	12.14	5.58	14.28	6.20	14.30	6.21	14.35	6.21	15.03	6.21
43	8.06	5.04	9.81	5.17	11.42	5.81	13.44	6.21	13.46	6.21	13.50	6.21	14.15	6.21	
45	7.56	5.24	9.20	5.37	10.71	6.04	12.60	6.21	12.62	6.21	12.66	6.21	13.27	6.21	
48	7.06	5.48	8.58	5.62	10.00	6.21	11.76	6.21	11.78	6.21	11.81	6.21	12.38	6.21	

Abbreviations:

CR: Combination ratio

TC: Total capacity (kW)

PI: Power input (compressor + outdoor fan motor) (kW)

Notes:

1. Shaded cells indicate rating condition.

Table continued on next page ...

Table 2-8.4: BCSF060NOA8-DTM160 cooling capacity (continued)

CR	Outdoor air temp. (°C DB)	Indoor air temp. (°C DB / °C WB)													
		20.8 / 14.0		23.3 / 16.0		25.8 / 18.0		27.0 / 19.0		28.2 / 20.0		30.7 / 22.0		32.0 / 24.0	
		TC kW	PI kW	TC kW	PI kW	TC kW	PI kW	TC kW	PI kW	TC kW	PI kW	TC kW	PI kW	TC kW	PI kW
110%	-5	9.24	1.92	11.24	1.96	13.09	2.21	15.40	2.46	15.43	2.70	15.47	2.95	16.21	3.44
	-2	9.24	1.95	11.24	2.00	13.09	2.25	15.40	2.50	15.43	2.75	15.47	3.00	16.21	3.51
	0	9.24	1.99	11.24	2.04	13.09	2.30	15.40	2.55	15.43	2.81	15.47	3.06	16.21	3.57
	2	9.24	2.03	11.24	2.08	13.09	2.34	15.40	2.60	15.43	2.86	15.47	3.12	16.21	3.64
	4	9.24	2.07	11.24	2.12	13.09	2.38	15.40	2.65	15.43	2.91	15.47	3.18	16.21	3.71
	6	9.24	2.10	11.24	2.16	13.09	2.43	15.40	2.70	15.43	2.97	15.47	3.24	16.21	3.77
	8	9.24	2.14	11.24	2.20	13.09	2.47	15.40	2.74	15.43	3.02	15.47	3.29	16.21	3.84
	10	9.24	2.18	11.24	2.23	13.09	2.51	15.40	2.79	15.43	3.07	15.47	3.35	16.21	3.91
	12	9.24	2.22	11.24	2.27	13.09	2.56	15.40	2.84	15.43	3.12	15.47	3.41	16.21	3.98
	14	9.24	2.25	11.24	2.31	13.09	2.60	15.40	2.89	15.43	3.18	15.47	3.47	16.21	4.04
	16	9.24	2.29	11.24	2.35	13.09	2.64	15.40	2.94	15.43	3.23	15.47	3.52	16.21	4.11
	18	9.24	2.37	11.24	2.43	13.09	2.73	15.40	3.03	15.43	3.34	15.47	3.64	16.21	4.25
	20	9.24	2.55	11.24	2.62	13.09	2.95	15.40	3.27	15.43	3.60	15.47	3.93	16.21	4.58
	21	9.24	2.67	11.24	2.73	13.09	3.08	15.40	3.42	15.43	3.76	15.47	4.10	16.21	4.79
	23	9.24	2.78	11.24	2.85	13.09	3.21	15.40	3.56	15.43	3.92	15.47	4.28	16.21	4.99
	25	9.24	2.89	11.24	2.97	13.09	3.34	15.40	3.71	15.43	4.08	15.47	4.45	16.21	5.19
	27	9.24	2.97	11.24	3.04	13.09	3.42	15.40	3.80	15.43	4.18	15.47	4.56	16.21	5.33
	29	9.24	3.04	11.24	3.12	13.09	3.51	15.40	3.90	15.43	4.29	15.47	4.68	16.21	5.46
	31	9.24	3.19	11.24	3.27	13.09	3.68	15.40	4.09	15.43	4.50	15.47	4.71	16.21	5.73
	33	9.24	3.27	11.24	3.35	13.09	3.77	15.40	4.19	15.43	4.61	15.47	4.65	16.21	5.67
35	9.24	3.41	11.24	3.50	13.09	3.94	15.40	4.38	15.43	4.60	15.47	4.86	16.21	5.64	
37	8.69	3.41	10.57	3.49	12.30	3.93	14.48	4.37	14.50	4.58	14.54	4.85	15.24	5.54	
39	8.32	3.86	10.12	3.96	11.78	4.45	13.86	4.95	13.88	5.19	13.92	5.49	14.59	6.14	
41	7.85	4.10	9.56	4.20	11.13	4.73	13.09	5.25	13.11	5.52	13.15	5.83	13.78	6.21	
43	7.39	4.27	8.99	4.38	10.47	4.92	12.32	5.47	12.34	5.75	12.38	6.07	12.97	6.21	
45	6.93	4.44	8.43	4.55	9.82	5.12	11.55	5.69	11.57	5.97	11.60	6.21	12.16	6.21	
48	6.47	4.64	7.87	4.76	9.16	5.36	10.78	5.95	10.80	6.21	10.83	6.21	11.35	6.21	
100%	-5	8.40	1.68	10.22	1.73	11.90	1.94	14.00	2.16	14.02	2.38	14.06	2.59	14.74	3.02
	-2	8.40	1.71	10.22	1.76	11.90	1.98	14.00	2.19	14.02	2.41	14.06	2.63	14.74	3.07
	0	8.40	1.74	10.22	1.78	11.90	2.01	14.00	2.23	14.02	2.45	14.06	2.68	14.74	3.12
	2	8.40	1.77	10.22	1.81	11.90	2.04	14.00	2.27	14.02	2.49	14.06	2.72	14.74	3.17
	4	8.40	1.79	10.22	1.84	11.90	2.07	14.00	2.30	14.02	2.53	14.06	2.76	14.74	3.22
	6	8.40	1.82	10.22	1.87	11.90	2.10	14.00	2.34	14.02	2.57	14.06	2.80	14.74	3.27
	8	8.40	1.85	10.22	1.90	11.90	2.13	14.00	2.37	14.02	2.61	14.06	2.85	14.74	3.32
	10	8.40	1.88	10.22	1.93	11.90	2.17	14.00	2.41	14.02	2.65	14.06	2.89	14.74	3.37
	12	8.40	1.91	10.22	1.95	11.90	2.20	14.00	2.44	14.02	2.69	14.06	2.93	14.74	3.42
	14	8.40	1.93	10.22	1.98	11.90	2.23	14.00	2.48	14.02	2.73	14.06	2.97	14.74	3.47
	16	8.40	1.96	10.22	2.01	11.90	2.26	14.00	2.51	14.02	2.76	14.06	3.02	14.74	3.52
	18	8.40	1.99	10.22	2.04	11.90	2.29	14.00	2.55	14.02	2.80	14.06	3.06	14.74	3.57
	20	8.40	2.02	10.22	2.07	11.90	2.33	14.00	2.58	14.02	2.84	14.06	3.10	14.74	3.62
	21	8.40	2.04	10.22	2.10	11.90	2.36	14.00	2.62	14.02	2.88	14.06	3.14	14.74	3.67
	23	8.40	2.07	10.22	2.12	11.90	2.39	14.00	2.66	14.02	2.92	14.06	3.19	14.74	3.72
	25	8.40	2.10	10.22	2.15	11.90	2.42	14.00	2.69	14.02	2.96	14.06	3.23	14.74	3.77
	27	8.40	2.13	10.22	2.18	11.90	2.45	14.00	2.73	14.02	3.00	14.06	3.27	14.74	3.82
	29	8.40	2.18	10.22	2.24	11.90	2.52	14.00	2.80	14.02	3.08	14.06	3.36	14.74	3.92
	31	8.40	2.29	10.22	2.35	11.90	2.64	14.00	2.94	14.02	3.23	14.06	3.38	14.74	4.11
	33	8.40	2.51	10.22	2.58	11.90	2.90	14.00	3.22	14.02	3.54	14.06	3.58	14.74	4.36
35	8.40	2.76	10.22	2.83	11.90	3.19	14.00	3.54	14.02	3.72	14.06	3.93	14.74	4.56	
37	7.90	2.75	9.61	2.82	11.19	3.18	13.16	3.53	13.18	3.71	13.22	3.92	13.85	4.48	
39	7.56	3.12	9.20	3.20	10.71	3.60	12.60	4.00	12.62	4.20	12.66	4.44	13.27	5.08	
41	7.14	3.31	8.69	3.40	10.12	3.82	11.90	4.25	11.92	4.46	11.96	4.72	12.53	5.28	
43	6.72	3.45	8.18	3.54	9.52	3.98	11.20	4.43	11.22	4.65	11.25	4.91	11.79	5.37	
45	6.30	3.59	7.67	3.68	8.93	4.14	10.50	4.60	10.52	4.83	10.55	5.11	11.05	5.53	
48	5.88	3.76	7.15	3.85	8.33	4.33	9.80	4.81	9.82	5.20	9.85	5.34	10.32	5.71	

Abbreviations:

CR: Combination ratio

TC: Total capacity (kW)

PI: Power input (compressor + outdoor fan motor) (kW)

Notes:

1. Shaded cells indicate rating condition.

Table continued on next page ...

Table 2-8.4: BCSF060N0A8-DTM160 cooling capacity (continued)

CR	Outdoor air temp. (°C DB)	Indoor air temp. (°C DB / °C WB)													
		20.8 / 14.0		23.3 / 16.0		25.8 / 18.0		27.0 / 19.0		28.2 / 20.0		30.7 / 22.0		32.0 / 24.0	
		TC kW	PI kW	TC kW	PI kW	TC kW	PI kW	TC kW	PI kW	TC kW	PI kW	TC kW	PI kW	TC kW	PI kW
90%	-5	7.56	1.46	9.20	1.49	10.71	1.68	12.60	1.87	12.62	2.05	12.66	2.24	13.27	2.61
	-2	7.56	1.48	9.20	1.52	10.71	1.71	12.60	1.90	12.62	2.09	12.66	2.28	13.27	2.65
	0	7.56	1.50	9.20	1.54	10.71	1.73	12.60	1.93	12.62	2.12	12.66	2.31	13.27	2.70
	2	7.56	1.53	9.20	1.57	10.71	1.76	12.60	1.96	12.62	2.15	12.66	2.35	13.27	2.74
	4	7.56	1.55	9.20	1.59	10.71	1.79	12.60	1.99	12.62	2.19	12.66	2.39	13.27	2.78
	6	7.56	1.57	9.20	1.61	10.71	1.82	12.60	2.02	12.62	2.22	12.66	2.42	13.27	2.83
	8	7.56	1.60	9.20	1.64	10.71	1.84	12.60	2.05	12.62	2.25	12.66	2.46	13.27	2.87
	10	7.56	1.62	9.20	1.66	10.71	1.87	12.60	2.08	12.62	2.29	12.66	2.50	13.27	2.91
	12	7.56	1.65	9.20	1.69	10.71	1.90	12.60	2.11	12.62	2.32	12.66	2.53	13.27	2.95
	14	7.56	1.67	9.20	1.71	10.71	1.93	12.60	2.14	12.62	2.36	12.66	2.57	13.27	3.00
	16	7.56	1.69	9.20	1.74	10.71	1.95	12.60	2.17	12.62	2.39	12.66	2.61	13.27	3.04
	18	7.56	1.72	9.20	1.76	10.71	1.98	12.60	2.20	12.62	2.42	12.66	2.64	13.27	3.08
	20	7.56	1.74	9.20	1.79	10.71	2.01	12.60	2.23	12.62	2.46	12.66	2.68	13.27	3.13
	21	7.56	1.77	9.20	1.81	10.71	2.04	12.60	2.26	12.62	2.49	12.66	2.72	13.27	3.17
	23	7.56	1.79	9.20	1.84	10.71	2.06	12.60	2.29	12.62	2.52	12.66	2.75	13.27	3.21
	25	7.56	1.81	9.20	1.86	10.71	2.09	12.60	2.32	12.62	2.56	12.66	2.79	13.27	3.25
	27	7.56	1.84	9.20	1.88	10.71	2.12	12.60	2.36	12.62	2.59	12.66	2.83	13.27	3.30
	29	7.56	1.88	9.20	1.93	10.71	2.17	12.60	2.42	12.62	2.66	12.66	2.90	13.27	3.38
	31	7.56	1.98	9.20	2.03	10.71	2.28	12.60	2.54	12.62	2.79	12.66	2.92	13.27	3.55
	33	7.56	2.17	9.20	2.23	10.71	2.50	12.60	2.78	12.62	3.06	12.66	3.09	13.27	3.76
35	7.56	2.39	9.20	2.45	10.71	2.75	12.60	3.06	12.62	3.21	12.66	3.40	13.27	3.94	
37	7.11	2.38	8.65	2.44	10.07	2.75	11.84	3.05	11.86	3.20	11.90	3.39	12.47	3.87	
39	6.80	2.46	8.28	2.52	9.64	2.84	11.34	3.15	11.36	3.31	11.39	3.50	11.94	4.00	
41	6.43	2.50	7.82	2.57	9.10	2.89	10.71	3.21	10.73	3.37	10.76	3.56	11.28	3.99	
43	6.05	2.55	7.36	2.62	8.57	2.95	10.08	3.27	10.10	3.44	10.13	3.63	10.61	3.97	
45	5.67	2.72	6.90	2.79	8.03	3.14	9.45	3.49	9.47	3.66	9.49	3.87	9.95	4.19	
48	5.29	2.82	6.44	2.89	7.50	3.25	8.82	3.61	8.84	3.90	8.86	4.01	9.29	4.28	
80%	-5	6.72	1.20	8.18	1.23	9.52	1.38	11.20	1.54	11.22	1.69	11.25	1.84	11.79	2.15
	-2	6.72	1.22	8.18	1.25	9.52	1.41	11.20	1.56	11.22	1.72	11.25	1.88	11.79	2.19
	0	6.72	1.24	8.18	1.27	9.52	1.43	11.20	1.59	11.22	1.75	11.25	1.91	11.79	2.22
	2	6.72	1.26	8.18	1.29	9.52	1.45	11.20	1.61	11.22	1.77	11.25	1.94	11.79	2.26
	4	6.72	1.28	8.18	1.31	9.52	1.47	11.20	1.64	11.22	1.80	11.25	1.97	11.79	2.29
	6	6.72	1.30	8.18	1.33	9.52	1.50	11.20	1.66	11.22	1.83	11.25	2.00	11.79	2.33
	8	6.72	1.32	8.18	1.35	9.52	1.52	11.20	1.69	11.22	1.86	11.25	2.03	11.79	2.36
	10	6.72	1.34	8.18	1.37	9.52	1.54	11.20	1.71	11.22	1.89	11.25	2.06	11.79	2.40
	12	6.72	1.36	8.18	1.39	9.52	1.57	11.20	1.74	11.22	1.91	11.25	2.09	11.79	2.43
	14	6.72	1.38	8.18	1.41	9.52	1.59	11.20	1.76	11.22	1.94	11.25	2.12	11.79	2.47
	16	6.72	1.40	8.18	1.43	9.52	1.61	11.20	1.79	11.22	1.97	11.25	2.15	11.79	2.51
	18	6.72	1.42	8.18	1.45	9.52	1.63	11.20	1.81	11.22	2.00	11.25	2.18	11.79	2.54
	20	6.72	1.44	8.18	1.47	9.52	1.66	11.20	1.84	11.22	2.02	11.25	2.21	11.79	2.58
	21	6.72	1.45	8.18	1.49	9.52	1.68	11.20	1.87	11.22	2.05	11.25	2.24	11.79	2.61
	23	6.72	1.47	8.18	1.51	9.52	1.70	11.20	1.89	11.22	2.08	11.25	2.27	11.79	2.65
	25	6.72	1.49	8.18	1.53	9.52	1.72	11.20	1.92	11.22	2.11	11.25	2.30	11.79	2.68
	27	6.72	1.51	8.18	1.55	9.52	1.75	11.20	1.94	11.22	2.13	11.25	2.33	11.79	2.72
	29	6.72	1.55	8.18	1.59	9.52	1.79	11.20	1.99	11.22	2.19	11.25	2.39	11.79	2.79
	31	6.72	1.63	8.18	1.67	9.52	1.88	11.20	2.09	11.22	2.30	11.25	2.41	11.79	2.93
	33	6.72	1.79	8.18	1.83	9.52	2.06	11.20	2.29	11.22	2.52	11.25	2.55	11.79	3.10
35	6.72	1.97	8.18	2.02	9.52	2.27	11.20	2.52	11.22	2.65	11.25	2.80	11.79	3.25	
37	6.32	1.96	7.69	2.01	8.95	2.26	10.53	2.51	10.55	2.64	10.58	2.79	11.08	3.19	
39	6.05	2.02	7.36	2.08	8.57	2.34	10.08	2.60	10.10	2.73	10.13	2.88	10.61	3.30	
41	5.71	2.06	6.95	2.12	8.09	2.38	9.52	2.65	9.54	2.78	9.56	2.94	10.02	3.29	
43	5.38	2.10	6.54	2.16	7.62	2.43	8.96	2.70	8.98	2.83	9.00	2.99	9.43	3.28	
45	5.04	2.24	6.13	2.30	7.14	2.59	8.40	2.87	8.41	3.02	8.44	3.19	8.84	3.45	
48	4.70	2.32	5.72	2.38	6.66	2.68	7.84	2.97	7.85	3.21	7.88	3.30	8.25	3.53	

Abbreviations:

CR: Combination ratio

TC: Total capacity (kW)

PI: Power input (compressor + outdoor fan motor) (kW)

Notes:

1. Shaded cells indicate rating condition.

Table continued on next page ...

Table 2-8.4: BCSF060N0A8-DTM160 cooling capacity (continued)

CR	Outdoor air temp. (°C DB)	Indoor air temp. (°C DB / °C WB)													
		20.8 / 14.0		23.3 / 16.0		25.8 / 18.0		27.0 / 19.0		28.2 / 20.0		30.7 / 22.0		32.0 / 24.0	
		TC kW	PI kW	TC kW	PI kW	TC kW	PI kW	TC kW	PI kW	TC kW	PI kW	TC kW	PI kW	TC kW	PI kW
70%	-5	5.88	1.03	7.15	1.06	8.33	1.19	9.80	1.33	9.82	1.46	9.85	1.59	10.32	1.86
	-2	5.88	1.04	7.15	1.07	8.33	1.20	9.80	1.34	9.82	1.47	9.85	1.60	10.32	1.87
	0	5.88	1.06	7.15	1.09	8.33	1.22	9.80	1.36	9.82	1.49	9.85	1.63	10.32	1.90
	2	5.88	1.07	7.15	1.10	8.33	1.24	9.80	1.38	9.82	1.52	9.85	1.65	10.32	1.93
	4	5.88	1.09	7.15	1.12	8.33	1.26	9.80	1.40	9.82	1.54	9.85	1.68	10.32	1.96
	6	5.88	1.11	7.15	1.14	8.33	1.28	9.80	1.42	9.82	1.56	9.85	1.70	10.32	1.99
	8	5.88	1.12	7.15	1.15	8.33	1.30	9.80	1.44	9.82	1.58	9.85	1.73	10.32	2.02
	10	5.88	1.14	7.15	1.17	8.33	1.31	9.80	1.46	9.82	1.61	9.85	1.75	10.32	2.04
	12	5.88	1.16	7.15	1.18	8.33	1.33	9.80	1.48	9.82	1.63	9.85	1.78	10.32	2.07
	14	5.88	1.17	7.15	1.20	8.33	1.35	9.80	1.50	9.82	1.65	9.85	1.80	10.32	2.10
	16	5.88	1.19	7.15	1.22	8.33	1.37	9.80	1.52	9.82	1.67	9.85	1.83	10.32	2.13
	18	5.88	1.20	7.15	1.23	8.33	1.39	9.80	1.54	9.82	1.70	9.85	1.85	10.32	2.16
	20	5.88	1.21	7.15	1.24	8.33	1.40	9.80	1.55	9.82	1.71	9.85	1.86	10.32	2.17
	21	5.88	1.22	7.15	1.25	8.33	1.41	9.80	1.56	9.82	1.72	9.85	1.88	10.32	2.19
	23	5.88	1.23	7.15	1.26	8.33	1.42	9.80	1.57	9.82	1.73	9.85	1.89	10.32	2.20
	25	5.88	1.24	7.15	1.27	8.33	1.43	9.80	1.58	9.82	1.74	9.85	1.90	10.32	2.22
	27	5.88	1.24	7.15	1.28	8.33	1.43	9.80	1.59	9.82	1.75	9.85	1.91	10.32	2.23
	29	5.88	1.27	7.15	1.30	8.33	1.46	9.80	1.62	9.82	1.79	9.85	1.95	10.32	2.27
	31	5.88	1.33	7.15	1.37	8.33	1.54	9.80	1.71	9.82	1.88	9.85	1.96	10.32	2.39
	33	5.88	1.46	7.15	1.50	8.33	1.68	9.80	1.87	9.82	2.06	9.85	2.08	10.32	2.53
35	5.88	1.60	7.15	1.65	8.33	1.85	9.80	2.06	9.82	2.16	9.85	2.28	10.32	2.65	
37	5.53	1.60	6.72	1.64	7.83	1.85	9.21	2.05	9.23	2.15	9.25	2.28	9.70	2.60	
39	5.29	1.65	6.44	1.69	7.50	1.91	8.82	2.12	8.84	2.22	8.86	2.35	9.29	2.69	
41	5.00	1.68	6.08	1.73	7.08	1.94	8.33	2.16	8.34	2.27	8.37	2.40	8.77	2.68	
43	4.70	1.72	5.72	1.76	6.66	1.98	7.84	2.20	7.85	2.31	7.88	2.44	8.25	2.67	
45	4.41	1.83	5.37	1.88	6.25	2.11	7.35	2.34	7.36	2.46	7.38	2.60	7.74	2.82	
48	4.12	1.89	5.01	1.94	5.83	2.18	6.86	2.43	6.87	2.62	6.89	2.69	7.22	2.88	
60%	-5	5.04	0.82	6.13	0.84	7.14	0.95	8.40	1.05	8.41	1.16	8.44	1.27	8.84	1.48
	-2	5.04	0.83	6.13	0.85	7.14	0.96	8.40	1.06	8.41	1.17	8.44	1.28	8.84	1.49
	0	5.04	0.84	6.13	0.86	7.14	0.97	8.40	1.08	8.41	1.19	8.44	1.30	8.84	1.51
	2	5.04	0.85	6.13	0.88	7.14	0.99	8.40	1.10	8.41	1.21	8.44	1.31	8.84	1.53
	4	5.04	0.87	6.13	0.89	7.14	1.00	8.40	1.11	8.41	1.22	8.44	1.33	8.84	1.56
	6	5.04	0.88	6.13	0.90	7.14	1.02	8.40	1.13	8.41	1.24	8.44	1.35	8.84	1.58
	8	5.04	0.89	6.13	0.92	7.14	1.03	8.40	1.14	8.41	1.26	8.44	1.37	8.84	1.60
	10	5.04	0.91	6.13	0.93	7.14	1.05	8.40	1.16	8.41	1.28	8.44	1.39	8.84	1.63
	12	5.04	0.92	6.13	0.94	7.14	1.06	8.40	1.18	8.41	1.30	8.44	1.41	8.84	1.65
	14	5.04	0.93	6.13	0.96	7.14	1.07	8.40	1.19	8.41	1.31	8.44	1.43	8.84	1.67
	16	5.04	0.94	6.13	0.97	7.14	1.09	8.40	1.21	8.41	1.33	8.44	1.45	8.84	1.69
	18	5.04	0.96	6.13	0.98	7.14	1.10	8.40	1.23	8.41	1.35	8.44	1.47	8.84	1.72
	20	5.04	0.96	6.13	0.99	7.14	1.11	8.40	1.23	8.41	1.36	8.44	1.48	8.84	1.73
	21	5.04	0.97	6.13	0.99	7.14	1.12	8.40	1.24	8.41	1.37	8.44	1.49	8.84	1.74
	23	5.04	0.98	6.13	1.00	7.14	1.13	8.40	1.25	8.41	1.38	8.44	1.50	8.84	1.75
	25	5.04	0.98	6.13	1.01	7.14	1.13	8.40	1.26	8.41	1.39	8.44	1.51	8.84	1.76
	27	5.04	0.99	6.13	1.01	7.14	1.14	8.40	1.27	8.41	1.39	8.44	1.52	8.84	1.77
	29	5.04	1.01	6.13	1.03	7.14	1.16	8.40	1.29	8.41	1.42	8.44	1.55	8.84	1.81
	31	5.04	1.06	6.13	1.09	7.14	1.22	8.40	1.36	8.41	1.49	8.44	1.56	8.84	1.90
	33	5.04	1.16	6.13	1.19	7.14	1.34	8.40	1.49	8.41	1.64	8.44	1.65	8.84	2.01
35	5.04	1.28	6.13	1.31	7.14	1.47	8.40	1.64	8.41	1.72	8.44	1.82	8.84	2.11	
37	4.74	1.27	5.76	1.31	6.71	1.47	7.90	1.63	7.91	1.71	7.93	1.81	8.31	2.07	
39	4.54	1.31	5.52	1.35	6.43	1.52	7.56	1.68	7.57	1.77	7.60	1.87	7.96	2.14	
41	4.28	1.34	5.21	1.37	6.07	1.55	7.14	1.72	7.15	1.80	7.17	1.91	7.52	2.13	
43	4.03	1.36	4.91	1.40	5.71	1.57	6.72	1.75	6.73	1.84	6.75	1.94	7.07	2.13	
45	3.78	1.45	4.60	1.49	5.36	1.68	6.30	1.86	6.31	1.96	6.33	2.07	6.63	2.24	
48	3.53	1.51	4.29	1.54	5.00	1.74	5.88	1.93	5.89	2.08	5.91	2.14	6.19	2.29	

Abbreviations:

CR: Combination ratio

TC: Total capacity (kW)

PI: Power input (compressor + outdoor fan motor) (kW)

Notes:

1. Shaded cells indicate rating condition.

Table continued on next page ...

Table 2-8.4: BCSF060N0A8-DTM160 cooling capacity (continued)

CR	Outdoor air temp. (°C DB)	Indoor air temp. (°C DB / °C WB)													
		20.8 / 14.0		23.3 / 16.0		25.8 / 18.0		27.0 / 19.0		28.2 / 20.0		30.7 / 22.0		32.0 / 24.0	
		TC kW	PI kW	TC kW	PI kW	TC kW	PI kW	TC kW	PI kW	TC kW	PI kW	TC kW	PI kW	TC kW	PI kW
50%	-5	4.20	0.64	5.11	0.66	5.95	0.74	7.00	0.82	7.01	0.90	7.03	0.99	7.37	1.15
	-2	4.20	0.65	5.11	0.66	5.95	0.75	7.00	0.83	7.01	0.91	7.03	0.99	7.37	1.16
	0	4.20	0.66	5.11	0.67	5.95	0.76	7.00	0.84	7.01	0.93	7.03	1.01	7.37	1.18
	2	4.20	0.67	5.11	0.68	5.95	0.77	7.00	0.85	7.01	0.94	7.03	1.02	7.37	1.20
	4	4.20	0.68	5.11	0.69	5.95	0.78	7.00	0.87	7.01	0.95	7.03	1.04	7.37	1.21
	6	4.20	0.69	5.11	0.70	5.95	0.79	7.00	0.88	7.01	0.97	7.03	1.06	7.37	1.23
	8	4.20	0.70	5.11	0.71	5.95	0.80	7.00	0.89	7.01	0.98	7.03	1.07	7.37	1.25
	10	4.20	0.71	5.11	0.72	5.95	0.81	7.00	0.90	7.01	1.00	7.03	1.09	7.37	1.27
	12	4.20	0.72	5.11	0.73	5.95	0.83	7.00	0.92	7.01	1.01	7.03	1.10	7.37	1.28
	14	4.20	0.73	5.11	0.74	5.95	0.84	7.00	0.93	7.01	1.02	7.03	1.12	7.37	1.30
	16	4.20	0.74	5.11	0.75	5.95	0.85	7.00	0.94	7.01	1.04	7.03	1.13	7.37	1.32
	18	4.20	0.75	5.11	0.76	5.95	0.86	7.00	0.96	7.01	1.05	7.03	1.15	7.37	1.34
	20	4.20	0.75	5.11	0.77	5.95	0.87	7.00	0.96	7.01	1.06	7.03	1.15	7.37	1.35
	21	4.20	0.76	5.11	0.77	5.95	0.87	7.00	0.97	7.01	1.07	7.03	1.16	7.37	1.36
	23	4.20	0.76	5.11	0.78	5.95	0.88	7.00	0.97	7.01	1.07	7.03	1.17	7.37	1.36
	25	4.20	0.77	5.11	0.79	5.95	0.88	7.00	0.98	7.01	1.08	7.03	1.18	7.37	1.37
	27	4.20	0.77	5.11	0.79	5.95	0.89	7.00	0.99	7.01	1.09	7.03	1.19	7.37	1.38
	29	4.20	0.79	5.11	0.81	5.95	0.91	7.00	1.01	7.01	1.11	7.03	1.21	7.37	1.41
	31	4.20	0.83	5.11	0.85	5.95	0.95	7.00	1.06	7.01	1.16	7.03	1.22	7.37	1.48
	33	4.20	0.90	5.11	0.93	5.95	1.04	7.00	1.16	7.01	1.28	7.03	1.29	7.37	1.57
35	4.20	0.99	5.11	1.02	5.95	1.15	7.00	1.27	7.01	1.34	7.03	1.41	7.37	1.64	
37	3.95	0.99	4.80	1.02	5.59	1.14	6.58	1.27	6.59	1.33	6.61	1.41	6.93	1.61	
39	3.78	1.02	4.60	1.05	5.36	1.18	6.30	1.31	6.31	1.38	6.33	1.46	6.63	1.67	
41	3.57	1.04	4.34	1.07	5.06	1.20	5.95	1.34	5.96	1.41	5.98	1.49	6.26	1.66	
43	3.36	1.06	4.09	1.09	4.76	1.23	5.60	1.36	5.61	1.43	5.63	1.51	5.90	1.66	
45	3.15	1.13	3.83	1.16	4.46	1.31	5.25	1.45	5.26	1.53	5.27	1.61	5.53	1.74	
48	2.94	1.17	3.58	1.20	4.17	1.35	4.90	1.50	4.91	1.62	4.92	1.67	5.16	1.78	

Abbreviations:

CR: Combination ratio

TC: Total capacity (kW)

PI: Power input (compressor + outdoor fan motor) (kW)

Notes:

1. Shaded cells indicate rating condition.

Table 2-8.5: BCSF070N0A9-DTM190 cooling capacity

CR	Outdoor air temp. (°C DB)	Indoor air temp. (°C DB / °C WB)													
		20.8 / 14.0		23.3 / 16.0		25.8 / 18.0		27.0 / 19.0		28.2 / 20.0		30.7 / 22.0		32.0 / 24.0	
		TC	PI	TC	PI	TC	PI	TC	PI	TC	PI	TC	PI	TC	PI
		kW	kW	kW	kW	kW	kW	kW	kW	kW	kW	kW	kW	kW	kW
130%	-5	12.48	2.58	14.56	2.65	17.68	2.98	20.80	3.31	21.42	3.64	21.84	3.97	22.46	4.64
	-2	12.48	2.64	14.56	2.71	17.68	3.05	20.80	3.39	21.42	3.73	21.84	4.06	22.46	4.74
	0	12.48	2.64	14.56	2.71	17.68	3.05	20.80	3.39	21.42	3.73	21.84	4.06	22.46	4.74
	2	12.48	2.64	14.56	2.71	17.68	3.05	20.80	3.39	21.42	3.73	21.84	4.06	22.46	4.74
	4	12.48	2.70	14.56	2.77	17.68	3.12	20.80	3.46	21.42	3.81	21.84	4.15	22.46	4.85
	6	12.48	2.70	14.56	2.77	17.68	3.12	20.80	3.46	21.42	3.81	21.84	4.15	22.46	4.85
	8	12.48	2.70	14.56	2.77	17.68	3.12	20.80	3.46	21.42	3.81	21.84	4.15	22.46	4.85
	10	12.48	2.76	14.56	2.83	17.68	3.18	20.80	3.54	21.42	3.89	21.84	4.25	22.46	4.95
	12	12.48	2.82	14.56	2.89	17.68	3.25	20.80	3.61	21.42	3.97	21.84	4.34	22.46	5.06
	14	12.48	2.88	14.56	2.95	17.68	3.32	20.80	3.69	21.42	4.06	21.84	4.43	22.46	5.16
	16	12.48	2.99	14.56	3.07	17.68	3.45	20.80	3.84	21.42	4.22	21.84	4.61	22.46	5.37
	18	12.48	3.11	14.56	3.19	17.68	3.59	20.80	3.99	21.42	4.39	21.84	4.79	22.46	5.59
	20	12.48	3.41	14.56	3.49	17.68	3.93	20.80	4.37	21.42	4.80	21.84	5.24	22.46	6.11
	21	12.48	3.58	14.56	3.67	17.68	4.13	20.80	4.59	21.42	5.05	21.84	5.51	22.46	6.43
	23	12.48	3.76	14.56	3.85	17.68	4.34	20.80	4.82	21.42	5.30	21.84	5.78	22.46	6.54
	25	12.48	3.93	14.56	4.03	17.68	4.54	20.80	5.04	21.42	5.55	21.84	6.05	22.46	6.57
	27	12.48	4.11	14.56	4.22	17.68	4.74	20.80	5.27	21.42	5.80	21.84	6.32	21.88	6.61
	29	12.48	4.23	14.56	4.34	17.68	4.88	20.80	5.42	21.42	5.96	21.84	6.50	21.11	6.61
	31	12.48	4.29	14.56	4.40	17.68	4.95	20.80	5.49	21.42	6.04	21.84	6.61	20.72	6.61
	33	12.48	4.34	14.56	4.46	17.68	5.01	20.80	5.57	21.42	6.13	21.44	6.61	20.41	6.61
	35	12.48	4.52	14.56	4.63	17.68	5.21	20.80	5.79	21.42	6.18	21.02	6.61	20.10	6.61
	37	9.98	4.50	11.65	4.62	14.14	5.20	16.64	5.78	16.67	6.21	16.72	6.61	17.52	6.61
	39	9.36	4.09	10.92	4.20	13.26	4.72	15.60	5.84	15.63	6.35	14.09	6.61	16.42	6.61
	41	8.74	4.34	10.19	4.46	12.38	5.01	14.56	5.97	14.86	6.61	13.18	6.61	15.33	6.61
43	8.11	4.52	9.46	4.64	11.49	5.22	13.52	6.10	13.87	6.61	13.58	6.44	14.23	6.61	
45	7.49	4.71	8.74	4.83	10.61	5.43	12.48	6.23	12.88	6.61	12.54	6.61	13.14	6.61	
48	6.86	4.92	8.01	5.05	9.72	5.68	11.44	6.31	11.46	6.61	11.49	6.61	12.04	6.61	
120%	-5	11.52	2.32	14.02	2.38	16.32	2.68	19.20	2.97	19.23	3.27	19.29	3.57	20.21	4.16
	-2	11.52	2.37	14.02	2.43	16.32	2.74	19.20	3.04	19.23	3.35	19.29	3.65	20.21	4.26
	0	11.52	2.37	14.02	2.43	16.32	2.74	19.20	3.04	19.23	3.35	19.29	3.65	20.21	4.26
	2	11.52	2.37	14.02	2.43	16.32	2.74	19.20	3.04	19.23	3.35	19.29	3.65	20.21	4.26
	4	11.52	2.43	14.02	2.49	16.32	2.80	19.20	3.11	19.23	3.42	19.29	3.73	20.21	4.35
	6	11.52	2.43	14.02	2.49	16.32	2.80	19.20	3.11	19.23	3.42	19.29	3.73	20.21	4.35
	8	11.52	2.43	14.02	2.49	16.32	2.80	19.20	3.11	19.23	3.42	19.29	3.73	20.21	4.35
	10	11.52	2.48	14.02	2.54	16.32	2.86	19.20	3.18	19.23	3.49	19.29	3.81	20.21	4.45
	12	11.52	2.53	14.02	2.60	16.32	2.92	19.20	3.24	19.23	3.57	19.29	3.89	20.21	4.54
	14	11.52	2.58	14.02	2.65	16.32	2.98	19.20	3.31	19.23	3.64	19.29	3.97	20.21	4.64
	16	11.52	2.69	14.02	2.76	16.32	3.10	19.20	3.45	19.23	3.79	19.29	4.14	20.21	4.83
	18	11.52	2.79	14.02	2.87	16.32	3.22	19.20	3.58	19.23	3.94	19.29	4.30	20.21	5.02
	20	11.52	3.06	14.02	3.14	16.32	3.53	19.20	3.92	19.23	4.31	19.29	4.70	20.21	5.49
	21	11.52	3.22	14.02	3.30	16.32	3.71	19.20	4.12	19.23	4.54	19.29	4.95	20.21	5.77
	23	11.52	3.37	14.02	3.46	16.32	3.89	19.20	4.33	19.23	4.76	19.29	5.19	20.21	6.06
	25	11.52	3.53	14.02	3.62	16.32	4.08	19.20	4.53	19.23	4.98	19.29	5.43	20.21	6.34
	27	11.52	3.85	14.02	3.95	16.32	4.44	19.20	4.93	19.23	5.43	19.29	5.92	20.21	6.61
	29	11.52	4.11	14.02	4.22	16.32	4.75	19.20	5.27	19.23	5.80	19.29	6.33	20.21	6.61
	31	11.52	4.22	14.02	4.33	16.32	4.87	19.20	5.41	19.23	5.95	19.29	6.22	20.21	6.61
	33	11.52	4.32	14.02	4.43	16.32	4.99	19.20	5.54	19.23	6.10	19.29	6.15	20.21	6.61
	35	11.52	4.39	14.02	4.51	16.32	5.07	19.20	5.63	19.23	5.91	19.29	6.25	20.21	6.61
	37	10.83	4.38	13.18	4.50	15.34	5.06	18.05	5.62	18.08	5.90	18.13	6.24	19.00	6.61
	39	10.37	4.96	12.61	5.09	14.69	5.73	17.28	6.37	17.31	6.61	17.36	6.61	18.19	6.61
	41	9.79	5.27	11.91	5.41	13.87	6.08	16.32	6.61	16.35	6.61	16.40	6.61	17.18	6.61
43	9.22	5.49	11.21	5.63	13.06	6.34	15.36	6.61	15.39	6.61	15.43	6.61	16.17	6.61	
45	8.64	5.71	10.51	5.86	12.24	6.59	14.40	6.61	14.43	6.61	14.47	6.61	15.16	6.61	
48	8.06	5.98	9.81	6.13	11.42	6.61	13.44	6.61	13.46	6.61	13.50	6.61	14.15	6.61	

Abbreviations:

CR: Combination ratio

TC: Total capacity (kW)

PI: Power input (compressor + outdoor fan motor) (kW)

Notes:

1. Shaded cells indicate rating condition.

Table continued on next page ...

Table 2-8.5: BCSF070N0A9-DTM190 cooling capacity (continued)

CR	Outdoor air temp. (°C DB)	Indoor air temp. (°C DB / °C WB)													
		20.8 / 14.0		23.3 / 16.0		25.8 / 18.0		27.0 / 19.0		28.2 / 20.0		30.7 / 22.0		32.0 / 24.0	
		TC kW	PI kW	TC kW	PI kW	TC kW	PI kW	TC kW	PI kW	TC kW	PI kW	TC kW	PI kW	TC kW	PI kW
110%	-5	10.56	2.09	12.85	2.14	14.96	2.41	17.60	2.68	17.63	2.95	17.68	6.61	18.53	3.75
	-2	10.56	2.13	12.85	2.18	14.96	2.46	17.60	2.73	17.63	3.00	17.68	3.28	18.53	3.82
	0	10.56	2.17	12.85	2.23	14.96	2.50	17.60	2.78	17.63	3.06	17.68	3.34	18.53	3.90
	2	10.56	2.21	12.85	2.27	14.96	2.55	17.60	2.84	17.63	3.12	17.68	3.40	18.53	3.97
	4	10.56	2.25	12.85	2.31	14.96	2.60	17.60	2.89	17.63	3.18	17.68	3.47	18.53	4.04
	6	10.56	2.29	12.85	2.35	14.96	2.65	17.60	2.94	17.63	3.23	17.68	3.53	18.53	4.12
	8	10.56	2.33	12.85	2.39	14.96	2.69	17.60	2.99	17.63	3.29	17.68	3.59	18.53	4.19
	10	10.56	2.38	12.85	2.44	14.96	2.74	17.60	3.05	17.63	3.35	17.68	3.65	18.53	4.26
	12	10.56	2.42	12.85	2.48	14.96	2.79	17.60	3.10	17.63	3.41	17.68	3.72	18.53	4.34
	14	10.56	2.46	12.85	2.52	14.96	2.84	17.60	3.15	17.63	3.47	17.68	3.78	18.53	4.41
	16	10.56	2.50	12.85	2.56	14.96	2.88	17.60	3.20	17.63	3.52	17.68	3.84	18.53	4.48
	18	10.56	2.58	12.85	2.65	14.96	2.98	17.60	3.31	17.63	3.64	17.68	3.97	18.53	4.63
	20	10.56	2.78	12.85	2.86	14.96	3.21	17.60	3.57	17.63	3.93	17.68	4.28	18.53	5.00
	21	10.56	2.91	12.85	2.98	14.96	3.35	17.60	3.73	17.63	4.10	17.68	4.47	18.53	5.22
	23	10.56	3.03	12.85	3.11	14.96	3.50	17.60	3.89	17.63	4.27	17.68	4.66	18.53	5.44
	25	10.56	3.15	12.85	3.23	14.96	3.64	17.60	4.04	17.63	4.45	17.68	4.85	18.53	5.66
	27	10.56	3.24	12.85	3.32	14.96	3.73	17.60	4.15	17.63	4.56	17.68	4.98	18.53	5.81
	29	10.56	3.32	12.85	3.40	14.96	3.83	17.60	4.25	17.63	4.68	17.68	5.10	18.53	5.95
	31	10.56	3.48	12.85	3.57	14.96	4.02	17.60	4.46	17.63	4.91	17.68	5.13	18.53	6.25
	33	10.56	3.56	12.85	3.65	14.96	4.11	17.60	4.57	17.63	5.02	17.68	5.07	18.53	6.18
35	10.56	3.72	12.85	3.82	14.96	4.30	17.60	4.77	17.63	5.01	17.68	5.30	18.53	6.15	
37	9.93	3.71	12.08	3.81	14.06	4.28	16.54	4.76	16.57	5.00	16.62	5.28	17.42	6.04	
39	9.50	4.21	11.56	4.31	13.46	4.85	15.84	5.39	15.87	5.66	15.91	5.99	16.68	6.61	
41	8.98	4.47	10.92	4.58	12.72	5.15	14.96	5.73	14.99	6.01	15.03	6.36	15.75	6.61	
43	8.45	4.65	10.28	4.77	11.97	5.37	14.08	5.97	14.10	6.26	14.15	6.61	14.82	6.61	
45	7.92	4.84	9.64	4.96	11.22	5.58	13.20	6.20	13.22	6.52	13.26	6.61	13.90	6.61	
48	7.39	5.06	8.99	5.19	10.47	5.84	12.32	6.49	12.34	6.61	12.38	6.61	12.97	6.61	
100%	-5	9.60	1.84	11.68	1.88	13.60	2.12	16.00	2.35	16.03	2.59	16.07	2.83	16.84	3.30
	-2	9.60	1.87	11.68	1.91	13.60	2.15	16.00	2.39	16.03	2.63	16.07	2.87	16.84	3.35
	0	9.60	1.90	11.68	1.95	13.60	2.19	16.00	2.43	16.03	2.67	16.07	2.92	16.84	3.40
	2	9.60	1.93	11.68	1.98	13.60	2.22	16.00	2.47	16.03	2.72	16.07	2.96	16.84	3.46
	4	9.60	1.96	11.68	2.01	13.60	2.26	16.00	2.51	16.03	2.76	16.07	3.01	16.84	3.51
	6	9.60	1.99	11.68	2.04	13.60	2.29	16.00	2.55	16.03	2.80	16.07	3.06	16.84	3.57
	8	9.60	2.02	11.68	2.07	13.60	2.33	16.00	2.59	16.03	2.84	16.07	3.10	16.84	3.62
	10	9.60	2.05	11.68	2.10	13.60	2.36	16.00	2.62	16.03	2.89	16.07	3.15	16.84	3.67
	12	9.60	2.08	11.68	2.13	13.60	2.40	16.00	2.66	16.03	2.93	16.07	3.20	16.84	3.73
	14	9.60	2.11	11.68	2.16	13.60	2.43	16.00	2.70	16.03	2.97	16.07	3.24	16.84	3.78
	16	9.60	2.14	11.68	2.19	13.60	2.47	16.00	2.74	16.03	3.01	16.07	3.29	16.84	3.84
	18	9.60	2.17	11.68	2.22	13.60	2.50	16.00	2.78	16.03	3.06	16.07	3.34	16.84	3.89
	20	9.60	2.20	11.68	2.25	13.60	2.54	16.00	2.82	16.03	3.10	16.07	3.38	16.84	3.94
	21	9.60	2.23	11.68	2.29	13.60	2.57	16.00	2.86	16.03	3.14	16.07	3.43	16.84	4.00
	23	9.60	2.26	11.68	2.32	13.60	2.61	16.00	2.90	16.03	3.18	16.07	3.47	16.84	4.05
	25	9.60	2.29	11.68	2.35	13.60	2.64	16.00	2.93	16.03	3.23	16.07	3.52	16.84	4.11
	27	9.60	2.32	11.68	2.38	13.60	2.67	16.00	2.97	16.03	3.27	16.07	3.57	16.84	4.16
	29	9.60	2.38	11.68	2.44	13.60	2.74	16.00	3.05	16.03	3.35	16.07	3.66	16.84	4.27
	31	9.60	2.50	11.68	2.56	13.60	2.88	16.00	3.20	16.03	3.52	16.07	3.68	16.84	4.49
	33	9.60	2.74	11.68	2.81	13.60	3.16	16.00	3.51	16.03	3.86	16.07	3.90	16.84	4.75
35	9.60	3.01	11.68	3.09	13.60	3.47	16.00	3.86	16.03	4.05	16.07	4.28	16.84	4.97	
37	9.02	3.00	10.98	3.08	12.78	3.47	15.04	3.85	15.07	4.04	15.11	4.27	15.83	4.89	
39	8.64	3.40	10.51	3.49	12.24	3.93	14.40	4.36	14.43	4.58	14.47	4.84	15.16	5.54	
41	8.16	3.61	9.93	3.71	11.56	4.17	13.60	4.63	13.62	4.86	13.66	5.14	14.32	5.75	
43	7.68	3.76	9.34	3.86	10.88	4.34	12.80	4.83	12.82	5.07	12.86	5.36	13.48	5.86	
45	7.20	3.91	8.76	4.01	10.20	4.52	12.00	5.02	12.02	5.27	12.06	5.57	12.63	6.02	
48	6.72	4.09	8.18	4.20	9.52	4.72	11.20	5.25	11.22	5.67	11.25	5.83	11.79	6.23	

Abbreviations:

CR: Combination ratio

TC: Total capacity (kW)

PI: Power input (compressor + outdoor fan motor) (kW)

Notes:

1. Shaded cells indicate rating condition.

Table continued on next page ...

Table 2-8.5: BCSF070N0A9-DTM190 cooling capacity (continued)

CR	Outdoor air temp. (°C DB)	Indoor air temp. (°C DB / °C WB)													
		20.8 / 14.0		23.3 / 16.0		25.8 / 18.0		27.0 / 19.0		28.2 / 20.0		30.7 / 22.0		32.0 / 24.0	
		TC	PI	TC	PI	TC	PI	TC	PI	TC	PI	TC	PI	TC	PI
		kW	kW	kW	kW	kW	kW	kW	kW	kW	kW	kW	kW	kW	kW
90%	-5	8.64	1.59	10.51	1.63	12.24	1.83	14.40	2.03	14.43	2.24	14.47	2.44	15.16	2.85
	-2	8.64	1.61	10.51	1.65	12.24	1.86	14.40	2.07	14.43	2.27	14.47	2.48	15.16	2.89
	0	8.64	1.64	10.51	1.68	12.24	1.89	14.40	2.10	14.43	2.31	14.47	2.52	15.16	2.94
	2	8.64	1.66	10.51	1.71	12.24	1.92	14.40	2.13	14.43	2.35	14.47	2.56	15.16	2.99
	4	8.64	1.69	10.51	1.73	12.24	1.95	14.40	2.17	14.43	2.38	14.47	2.60	15.16	3.03
	6	8.64	1.72	10.51	1.76	12.24	1.98	14.40	2.20	14.43	2.42	14.47	2.64	15.16	3.08
	8	8.64	1.74	10.51	1.79	12.24	2.01	14.40	2.23	14.43	2.46	14.47	2.68	15.16	3.13
	10	8.64	1.77	10.51	1.81	12.24	2.04	14.40	2.27	14.43	2.49	14.47	2.72	15.16	3.17
	12	8.64	1.79	10.51	1.84	12.24	2.07	14.40	2.30	14.43	2.53	14.47	2.76	15.16	3.22
	14	8.64	1.82	10.51	1.87	12.24	2.10	14.40	2.33	14.43	2.57	14.47	2.80	15.16	3.27
	16	8.64	1.85	10.51	1.89	12.24	2.13	14.40	2.37	14.43	2.60	14.47	2.84	15.16	3.32
	18	8.64	1.87	10.51	1.92	12.24	2.16	14.40	2.40	14.43	2.64	14.47	2.88	15.16	3.36
	20	8.64	1.90	10.51	1.95	12.24	2.19	14.40	2.43	14.43	2.68	14.47	2.92	15.16	3.41
	21	8.64	1.92	10.51	1.97	12.24	2.22	14.40	2.47	14.43	2.71	14.47	2.96	15.16	3.46
	23	8.64	1.95	10.51	2.00	12.24	2.25	14.40	2.50	14.43	2.75	14.47	3.00	15.16	3.50
	25	8.64	1.98	10.51	2.03	12.24	2.28	14.40	2.53	14.43	2.79	14.47	3.04	15.16	3.55
	27	8.64	2.00	10.51	2.05	12.24	2.31	14.40	2.57	14.43	2.82	14.47	3.08	15.16	3.60
	29	8.64	2.06	10.51	2.11	12.24	2.37	14.40	2.63	14.43	2.90	14.47	3.16	15.16	3.69
	31	8.64	2.16	10.51	2.21	12.24	2.49	14.40	2.77	14.43	3.04	14.47	3.18	15.16	3.88
	33	8.64	2.37	10.51	2.43	12.24	2.73	14.40	3.03	14.43	3.34	14.47	3.37	15.16	4.10
35	8.64	2.60	10.51	2.67	12.24	3.00	14.40	3.34	14.43	3.50	14.47	3.70	15.16	4.30	
37	8.12	2.59	9.88	2.66	11.51	2.99	13.54	3.33	13.56	3.49	13.60	3.69	14.25	4.22	
39	7.78	2.68	9.46	2.75	11.02	3.09	12.96	3.44	12.98	3.61	13.02	3.81	13.64	4.36	
41	7.34	2.73	8.94	2.80	10.40	3.15	12.24	3.50	12.26	3.68	12.30	3.89	12.89	4.35	
43	6.91	2.78	8.41	2.85	9.79	3.21	11.52	3.57	11.54	3.75	11.57	3.96	12.13	4.33	
45	6.48	2.97	7.88	3.04	9.18	3.42	10.80	3.80	10.82	3.99	10.85	4.22	11.37	4.56	
48	6.05	3.07	7.36	3.15	8.57	3.54	10.08	3.94	10.10	4.25	10.13	4.37	10.61	4.67	
80%	-5	7.68	1.31	9.34	1.34	10.88	1.51	12.80	1.68	12.82	1.84	12.86	2.01	13.48	2.35
	-2	7.68	1.33	9.34	1.36	10.88	1.53	12.80	1.70	12.82	1.87	12.86	2.04	13.48	2.39
	0	7.68	1.35	9.34	1.39	10.88	1.56	12.80	1.73	12.82	1.90	12.86	2.08	13.48	2.42
	2	7.68	1.37	9.34	1.41	10.88	1.58	12.80	1.76	12.82	1.93	12.86	2.11	13.48	2.46
	4	7.68	1.39	9.34	1.43	10.88	1.61	12.80	1.79	12.82	1.97	12.86	2.14	13.48	2.50
	6	7.68	1.41	9.34	1.45	10.88	1.63	12.80	1.81	12.82	2.00	12.86	2.18	13.48	2.54
	8	7.68	1.44	9.34	1.47	10.88	1.66	12.80	1.84	12.82	2.03	12.86	2.21	13.48	2.58
	10	7.68	1.46	9.34	1.50	10.88	1.68	12.80	1.87	12.82	2.06	12.86	2.24	13.48	2.62
	12	7.68	1.48	9.34	1.52	10.88	1.71	12.80	1.90	12.82	2.09	12.86	2.28	13.48	2.65
	14	7.68	1.50	9.34	1.54	10.88	1.73	12.80	1.92	12.82	2.12	12.86	2.31	13.48	2.69
	16	7.68	1.52	9.34	1.56	10.88	1.76	12.80	1.95	12.82	2.15	12.86	2.34	13.48	2.73
	18	7.68	1.54	9.34	1.58	10.88	1.78	12.80	1.98	12.82	2.18	12.86	2.37	13.48	2.77
	20	7.68	1.56	9.34	1.61	10.88	1.81	12.80	2.01	12.82	2.21	12.86	2.41	13.48	2.81
	21	7.68	1.59	9.34	1.63	10.88	1.83	12.80	2.03	12.82	2.24	12.86	2.44	13.48	2.85
	23	7.68	1.61	9.34	1.65	10.88	1.86	12.80	2.06	12.82	2.27	12.86	2.47	13.48	2.89
	25	7.68	1.63	9.34	1.67	10.88	1.88	12.80	2.09	12.82	2.30	12.86	2.51	13.48	2.92
	27	7.68	1.65	9.34	1.69	10.88	1.90	12.80	2.12	12.82	2.33	12.86	2.54	13.48	2.96
	29	7.68	1.69	9.34	1.74	10.88	1.95	12.80	2.17	12.82	2.39	12.86	2.61	13.48	3.04
	31	7.68	1.78	9.34	1.82	10.88	2.05	12.80	2.28	12.82	2.51	12.86	2.62	13.48	3.19
	33	7.68	1.95	9.34	2.00	10.88	2.25	12.80	2.50	12.82	2.75	12.86	2.78	13.48	3.38
35	7.68	2.14	9.34	2.20	10.88	2.47	12.80	2.75	12.82	2.89	12.86	3.05	13.48	3.54	
37	7.22	2.14	8.78	2.19	10.23	2.47	12.03	2.74	12.05	2.88	12.09	3.04	12.67	3.48	
39	6.91	2.21	8.41	2.26	9.79	2.55	11.52	2.83	11.54	2.97	11.57	3.14	12.13	3.59	
41	6.53	2.25	7.94	2.31	9.25	2.60	10.88	2.89	10.90	3.03	10.93	3.20	11.45	3.58	
43	6.14	2.29	7.48	2.35	8.70	2.65	10.24	2.94	10.26	3.09	10.29	3.26	10.78	3.57	
45	5.76	2.44	7.01	2.51	8.16	2.82	9.60	3.13	9.62	3.29	9.64	3.48	10.11	3.76	
48	5.38	2.53	6.54	2.59	7.62	2.92	8.96	3.24	8.98	3.50	9.00	3.60	9.43	3.85	

Abbreviations:

CR: Combination ratio

TC: Total capacity (kW)

PI: Power input (compressor + outdoor fan motor) (kW)

Notes:

1. Shaded cells indicate rating condition.

Table continued on next page ...

Table 2-8.5: BCSF070N0A9-DTM190 cooling capacity (continued)

CR	Outdoor air temp. (°C DB)	Indoor air temp. (°C DB / °C WB)													
		20.8 / 14.0		23.3 / 16.0		25.8 / 18.0		27.0 / 19.0		28.2 / 20.0		30.7 / 22.0		32.0 / 24.0	
		TC	PI	TC	PI	TC	PI	TC	PI	TC	PI	TC	PI	TC	PI
		kW	kW	kW	kW	kW	kW	kW	kW	kW	kW	kW	kW	kW	kW
70%	-5	6.72	1.13	8.18	1.16	9.52	1.30	11.20	1.45	11.22	1.59	11.25	1.74	11.79	2.03
	-2	6.72	1.14	8.18	1.17	9.52	1.31	11.20	1.46	11.22	1.60	11.25	1.75	11.79	2.04
	0	6.72	1.15	8.18	1.18	9.52	1.33	11.20	1.48	11.22	1.63	11.25	1.78	11.79	2.07
	2	6.72	1.17	8.18	1.20	9.52	1.35	11.20	1.50	11.22	1.65	11.25	1.80	11.79	2.10
	4	6.72	1.19	8.18	1.22	9.52	1.37	11.20	1.53	11.22	1.68	11.25	1.83	11.79	2.14
	6	6.72	1.21	8.18	1.24	9.52	1.39	11.20	1.55	11.22	1.70	11.25	1.86	11.79	2.17
	8	6.72	1.22	8.18	1.26	9.52	1.41	11.20	1.57	11.22	1.73	11.25	1.88	11.79	2.20
	10	6.72	1.24	8.18	1.27	9.52	1.43	11.20	1.59	11.22	1.75	11.25	1.91	11.79	2.23
	12	6.72	1.26	8.18	1.29	9.52	1.45	11.20	1.61	11.22	1.78	11.25	1.94	11.79	2.26
	14	6.72	1.28	8.18	1.31	9.52	1.47	11.20	1.64	11.22	1.80	11.25	1.96	11.79	2.29
	16	6.72	1.29	8.18	1.33	9.52	1.49	11.20	1.66	11.22	1.83	11.25	1.99	11.79	2.32
	18	6.72	1.31	8.18	1.35	9.52	1.51	11.20	1.68	11.22	1.85	11.25	2.02	11.79	2.35
	20	6.72	1.32	8.18	1.35	9.52	1.52	11.20	1.69	11.22	1.86	11.25	2.03	11.79	2.37
	21	6.72	1.33	8.18	1.36	9.52	1.53	11.20	1.70	11.22	1.87	11.25	2.05	11.79	2.39
	23	6.72	1.34	8.18	1.37	9.52	1.54	11.20	1.72	11.22	1.89	11.25	2.06	11.79	2.40
	25	6.72	1.35	8.18	1.38	9.52	1.55	11.20	1.73	11.22	1.90	11.25	2.07	11.79	2.42
	27	6.72	1.36	8.18	1.39	9.52	1.56	11.20	1.74	11.22	1.91	11.25	2.09	11.79	2.43
	29	6.72	1.38	8.18	1.42	9.52	1.59	11.20	1.77	11.22	1.95	11.25	2.13	11.79	2.48
	31	6.72	1.45	8.18	1.49	9.52	1.68	11.20	1.86	11.22	2.05	11.25	2.14	11.79	2.61
	33	6.72	1.59	8.18	1.63	9.52	1.84	11.20	2.04	11.22	2.24	11.25	2.27	11.79	2.76
35	6.72	1.75	8.18	1.79	9.52	2.02	11.20	2.24	11.22	2.35	11.25	2.49	11.79	2.89	
37	6.32	1.74	7.69	1.79	8.95	2.01	10.53	2.24	10.55	2.35	10.58	2.48	11.08	2.84	
39	6.05	1.80	7.36	1.85	8.57	2.08	10.08	2.31	10.10	2.43	10.13	2.56	10.61	2.93	
41	5.71	1.84	6.95	1.88	8.09	2.12	9.52	2.35	9.54	2.47	9.56	2.61	10.02	2.92	
43	5.38	1.87	6.54	1.92	7.62	2.16	8.96	2.40	8.98	2.52	9.00	2.66	9.43	2.91	
45	5.04	1.99	6.13	2.05	7.14	2.30	8.40	2.56	8.41	2.68	8.44	2.84	8.84	3.07	
48	4.70	2.06	5.72	2.12	6.66	2.38	7.84	2.65	7.85	2.86	7.88	2.94	8.25	3.14	
60%	-5	5.76	0.90	7.01	0.92	8.16	1.04	9.60	1.15	9.62	1.27	9.64	1.38	10.11	1.61
	-2	5.76	0.90	7.01	0.93	8.16	1.04	9.60	1.16	9.62	1.28	9.64	1.39	10.11	1.62
	0	5.76	0.92	7.01	0.94	8.16	1.06	9.60	1.18	9.62	1.29	9.64	1.41	10.11	1.65
	2	5.76	0.93	7.01	0.96	8.16	1.08	9.60	1.19	9.62	1.31	9.64	1.43	10.11	1.67
	4	5.76	0.95	7.01	0.97	8.16	1.09	9.60	1.21	9.62	1.33	9.64	1.46	10.11	1.70
	6	5.76	0.96	7.01	0.98	8.16	1.11	9.60	1.23	9.62	1.35	9.64	1.48	10.11	1.72
	8	5.76	0.97	7.01	1.00	8.16	1.12	9.60	1.25	9.62	1.37	9.64	1.50	10.11	1.75
	10	5.76	0.99	7.01	1.01	8.16	1.14	9.60	1.27	9.62	1.39	9.64	1.52	10.11	1.77
	12	5.76	1.00	7.01	1.03	8.16	1.16	9.60	1.28	9.62	1.41	9.64	1.54	10.11	1.80
	14	5.76	1.02	7.01	1.04	8.16	1.17	9.60	1.30	9.62	1.43	9.64	1.56	10.11	1.82
	16	5.76	1.03	7.01	1.06	8.16	1.19	9.60	1.32	9.62	1.45	9.64	1.58	10.11	1.85
	18	5.76	1.04	7.01	1.07	8.16	1.20	9.60	1.34	9.62	1.47	9.64	1.60	10.11	1.87
	20	5.76	1.05	7.01	1.08	8.16	1.21	9.60	1.35	9.62	1.48	9.64	1.62	10.11	1.88
	21	5.76	1.06	7.01	1.08	8.16	1.22	9.60	1.36	9.62	1.49	9.64	1.63	10.11	1.90
	23	5.76	1.06	7.01	1.09	8.16	1.23	9.60	1.36	9.62	1.50	9.64	1.64	10.11	1.91
	25	5.76	1.07	7.01	1.10	8.16	1.24	9.60	1.37	9.62	1.51	9.64	1.65	10.11	1.92
	27	5.76	1.08	7.01	1.11	8.16	1.24	9.60	1.38	9.62	1.52	9.64	1.66	10.11	1.93
	29	5.76	1.10	7.01	1.13	8.16	1.27	9.60	1.41	9.62	1.55	9.64	1.69	10.11	1.97
	31	5.76	1.15	7.01	1.18	8.16	1.33	9.60	1.48	9.62	1.63	9.64	1.70	10.11	2.07
	33	5.76	1.27	7.01	1.30	8.16	1.46	9.60	1.62	9.62	1.79	9.64	1.80	10.11	2.19
35	5.76	1.39	7.01	1.43	8.16	1.60	9.60	1.78	9.62	1.87	9.64	1.98	10.11	2.30	
37	5.41	1.39	6.59	1.42	7.67	1.60	9.02	1.78	9.04	1.87	9.07	1.97	9.50	2.26	
39	5.18	1.43	6.31	1.47	7.34	1.65	8.64	1.84	8.66	1.93	8.68	2.04	9.10	2.33	
41	4.90	1.46	5.96	1.50	6.94	1.69	8.16	1.87	8.17	1.97	8.20	2.08	8.59	2.33	
43	4.61	1.49	5.61	1.53	6.53	1.72	7.68	1.91	7.69	2.00	7.72	2.12	8.09	2.32	
45	4.32	1.59	5.26	1.63	6.12	1.83	7.20	2.03	7.21	2.13	7.23	2.26	7.58	2.44	
48	4.03	1.64	4.91	1.68	5.71	1.89	6.72	2.10	6.73	2.27	6.75	2.34	7.07	2.50	

Abbreviations:

CR: Combination ratio

TC: Total capacity (kW)

PI: Power input (compressor + outdoor fan motor) (kW)

Notes:

1. Shaded cells indicate rating condition.

Table continued on next page ...

Table 2-8.5: BCSF070NOA9-DTM190 cooling capacity (continued)

CR	Outdoor air temp. (°C DB)	Indoor air temp. (°C DB / °C WB)													
		20.8 / 14.0		23.3 / 16.0		25.8 / 18.0		27.0 / 19.0		28.2 / 20.0		30.7 / 22.0		32.0 / 24.0	
		TC	PI	TC	PI	TC	PI	TC	PI	TC	PI	TC	PI	TC	PI
		kW	kW	kW	kW	kW	kW	kW	kW	kW	kW	kW	kW	kW	kW
50%	-5	4.80	0.70	5.84	0.72	6.80	0.81	8.00	0.90	8.01	0.99	8.04	1.08	8.42	1.25
	-2	4.80	0.70	5.84	0.72	6.80	0.81	8.00	0.90	8.01	0.99	8.04	1.08	8.42	1.26
	0	4.80	0.72	5.84	0.73	6.80	0.83	8.00	0.92	8.01	1.01	8.04	1.10	8.42	1.28
	2	4.80	0.73	5.84	0.74	6.80	0.84	8.00	0.93	8.01	1.02	8.04	1.12	8.42	1.30
	4	4.80	0.74	5.84	0.76	6.80	0.85	8.00	0.94	8.01	1.04	8.04	1.13	8.42	1.32
	6	4.80	0.75	5.84	0.77	6.80	0.86	8.00	0.96	8.01	1.05	8.04	1.15	8.42	1.34
	8	4.80	0.76	5.84	0.78	6.80	0.88	8.00	0.97	8.01	1.07	8.04	1.17	8.42	1.36
	10	4.80	0.77	5.84	0.79	6.80	0.89	8.00	0.99	8.01	1.09	8.04	1.18	8.42	1.38
	12	4.80	0.78	5.84	0.80	6.80	0.90	8.00	1.00	8.01	1.10	8.04	1.20	8.42	1.40
	14	4.80	0.79	5.84	0.81	6.80	0.91	8.00	1.01	8.01	1.12	8.04	1.22	8.42	1.42
	16	4.80	0.80	5.84	0.82	6.80	0.93	8.00	1.03	8.01	1.13	8.04	1.23	8.42	1.44
	18	4.80	0.81	5.84	0.83	6.80	0.94	8.00	1.04	8.01	1.15	8.04	1.25	8.42	1.46
	20	4.80	0.82	5.84	0.84	6.80	0.94	8.00	1.05	8.01	1.15	8.04	1.26	8.42	1.47
	21	4.80	0.82	5.84	0.84	6.80	0.95	8.00	1.06	8.01	1.16	8.04	1.27	8.42	1.48
	23	4.80	0.83	5.84	0.85	6.80	0.96	8.00	1.06	8.01	1.17	8.04	1.28	8.42	1.49
	25	4.80	0.83	5.84	0.86	6.80	0.96	8.00	1.07	8.01	1.18	8.04	1.28	8.42	1.50
	27	4.80	0.84	5.84	0.86	6.80	0.97	8.00	1.08	8.01	1.18	8.04	1.29	8.42	1.51
	29	4.80	0.86	5.84	0.88	6.80	0.99	8.00	1.10	8.01	1.21	8.04	1.32	8.42	1.54
	31	4.80	0.90	5.84	0.92	6.80	1.04	8.00	1.15	8.01	1.27	8.04	1.33	8.42	1.61
	33	4.80	0.99	5.84	1.01	6.80	1.14	8.00	1.26	8.01	1.39	8.04	1.40	8.42	1.71
35	4.80	1.08	5.84	1.11	6.80	1.25	8.00	1.39	8.01	1.46	8.04	1.54	8.42	1.79	
37	4.51	1.08	5.49	1.11	6.39	1.25	7.52	1.39	7.53	1.46	7.55	1.54	7.92	1.76	
39	4.32	1.12	5.26	1.15	6.12	1.29	7.20	1.43	7.21	1.50	7.23	1.59	7.58	1.82	
41	4.08	1.14	4.96	1.17	5.78	1.31	6.80	1.46	6.81	1.53	6.83	1.62	7.16	1.81	
43	3.84	1.16	4.67	1.19	5.44	1.34	6.40	1.49	6.41	1.56	6.43	1.65	6.74	1.81	
45	3.60	1.24	4.38	1.27	5.10	1.43	6.00	1.58	6.01	1.66	6.03	1.76	6.32	1.90	
48	3.36	1.28	4.09	1.31	4.76	1.48	5.60	1.64	5.61	1.77	5.63	1.82	5.90	1.95	

Abbreviations:

CR: Combination ratio

TC: Total capacity (kW)

PI: Power input (compressor + outdoor fan motor) (kW)

Notes:

1. Shaded cells indicate rating condition.

8.2 Capacity Correction Factors for Piping Length and Level Difference

Figure 2-8.1: BCSF030, 040, 050 rate of change in cooling capacity

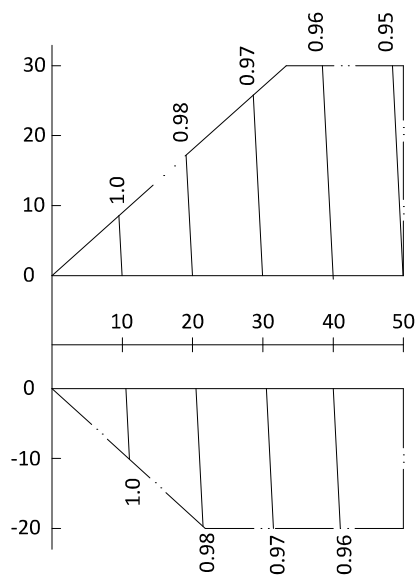
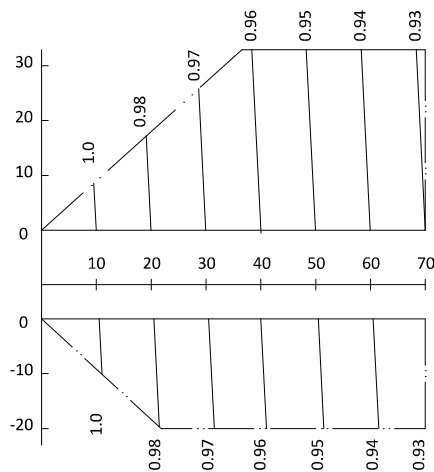

Figure 2-8.2: BCSF060, 070 rate of change in cooling capacity



Notes:

1. The horizontal axis shows equivalent length of piping between farthest indoor unit and outdoor unit; the vertical axis shows the largest level difference between indoor unit and outdoor unit. For level differences, positive values indicate that the outdoor unit is above the indoor unit, negative values indicate that the outdoor unit is below the indoor unit.
2. These figures illustrate the rate of change in capacity of a system with only standard indoor units at maximum load (with the thermostat set to maximum) under standard conditions. Under partial load conditions there is only a minor deviation from the rate of change in capacity shown in these figures.
3. The capacity of the system is either the total capacity of the indoor units obtained from indoor unit capacity tables or the corrected capacity of the outdoor unit as per the calculations below, whichever is smaller.

Corrected capacity of outdoor unit	=	Capacity of outdoor unit obtained from outdoor unit capacity tables at the combination ratio	x	Capacity correction factor
------------------------------------	---	--	---	----------------------------

9 Operating Limits

Figure 2-9.1: Cooling operating limits

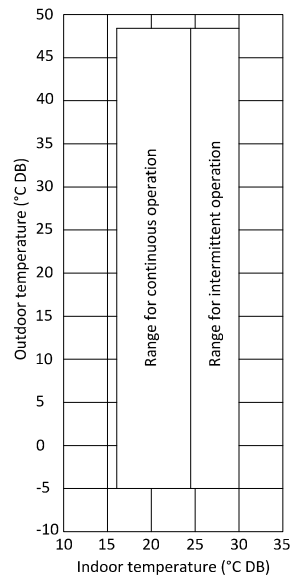

10 Sound Levels

10.1 Overall

Table 2-10.1: Sound pressure level

Model	dB(A)
BCSF030N0A4-DTM090	54
BCSF040N0A6-DTM115	54
BCSF050N0A7-DTM140	54
BCSF060N0A8-DTM160	55
BCSF070N0A9-DTM190	55

Notes:

1. Sound pressure level is measured at a position 1m in front of the unit and 1.3m above the floor in a semi-anechoic chamber. During in-situ operation, sound pressure levels may be higher as a result of ambient noise.

Figure 2-10.1: Sound pressure level measurement (unit: mm)

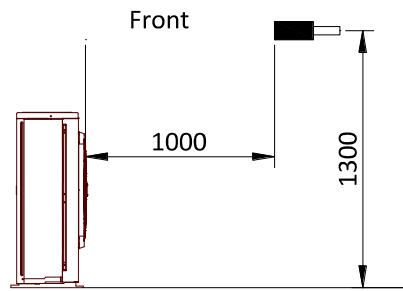

10.2 Octave Band Levels

Figure 2-10.2 BCSF030, 040 octave band level

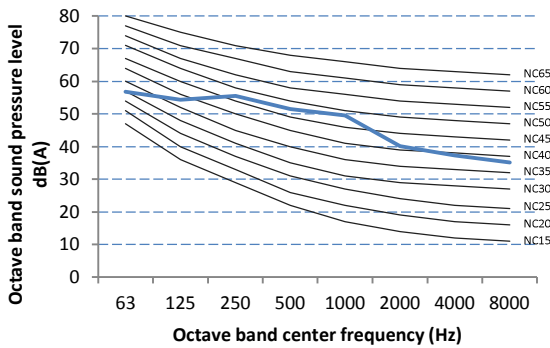

Figure 2-10.3 BCSF050N0A7-DTM140 octave band level

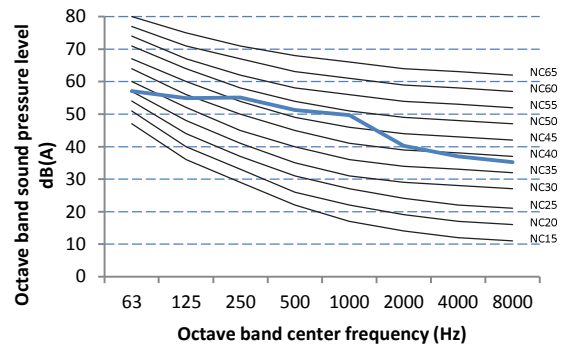

Figure 2-10.4 BCSF060N0A8-DTM160 octave band level

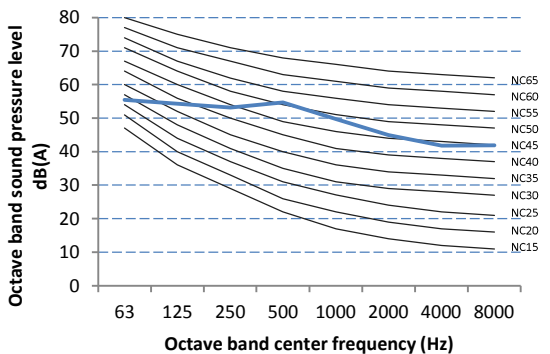
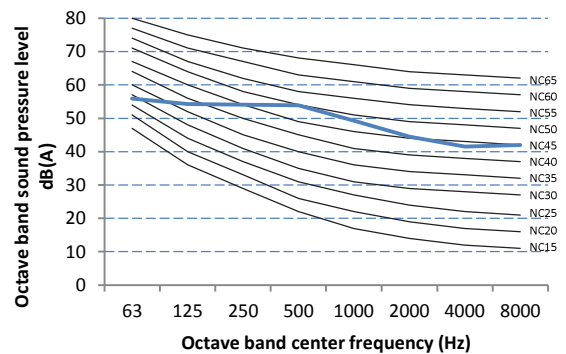



Figure 2-10.5 BCSF070N0A9-DTM190 octave band level



11 Accessories

11.1 Standard Accessories

Table 2-11.1: Standard accessories

Name	Shape	Quantity	Function
Outdoor unit installation manual		1	
Outdoor unit owner's manual		1	
Indoor unit owner's manual		1	
Connecting pipe (for 60/70 model)		1	For outdoor unit gas pipe connection

Part 3

System Design and Installation

1	Preface to Part 3	54
2	Unit Placement and Installation	55
3	Refrigerant Piping Design	59
4	Refrigerant Piping Installation	66
5	Drain Piping	77
6	Insulation.....	81
7	Charging Refrigerant	83
8	Electrical Wiring.....	85
9	Installation in Areas of High Salinity.....	89
10	Commissioning.....	90
11	Appendix to Part 3 – System Commissioning Report	92

1 Preface to Part 3

1.1 Notes for Installers Boxes

The information contained in this Engineering Data Book may primarily be of use during the system design stage of a OMEGA ULTIMA Series VRF project. Additional important information which may primarily be of use during field installation has been placed in boxes, such as the example below, titled “Notes for installers”.

Notes for installers



- Notes for installers boxes contain important information which may primarily be of use during field installation, rather than during desk-based system design.

1.2 Definitions

In this Engineering Data Book, the term “applicable legislation” refers to all national, local and other laws, standards, codes, rules, regulations and other legislation that apply in a given situation.

1.3 Precautions

All system installation including installation of piping and electrical works must only be carried out by competent and suitably qualified, certified and accredited professionals and in accordance with all applicable legislation.

2 Unit Placement and Installation

2.1 Outdoor Units

2.1.1 Placement considerations

Placement of outdoor units should take account of the following considerations:

- Air conditioners should not be exposed to direct radiation from a high-temperature heat source.
- Air conditioners should not be installed in positions where dust or dirt may affect heat exchangers.
- Air conditioners should not be installed in locations where exposure to oil or to corrosive or harmful gases, such as acidic or alkaline gases, may occur.
- Air conditioners should not be installed in locations where exposure to salinity may occur unless the anti-corrosion treatment for high-salinity areas customization option has been added and the precautions described in Part 3, 9 “Installation in Areas of High Salinity” are taken.
- Outdoor units should be installed in well-drained, well-ventilated positions that are as close as possible to the indoor units.

2.1.2 Spacing

Outdoor units must be spaced such that sufficient air may flow through each unit. Sufficient airflow across heat exchangers is essential for outdoor units to function properly. Figures 3-2.1 to 3-2.3 show spacing requirements in three different scenarios.

Figure 3-2.1: Single unit installation (unit: mm)

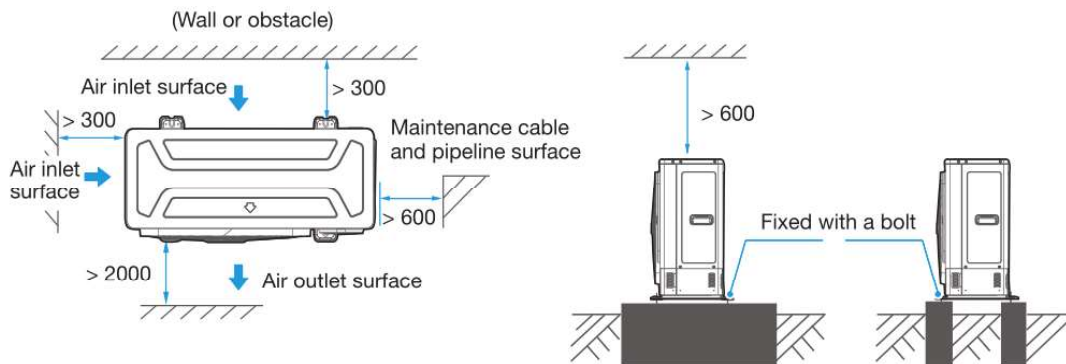

Figure 3-2.2: Parallel connect the two units or above (unit: mm)

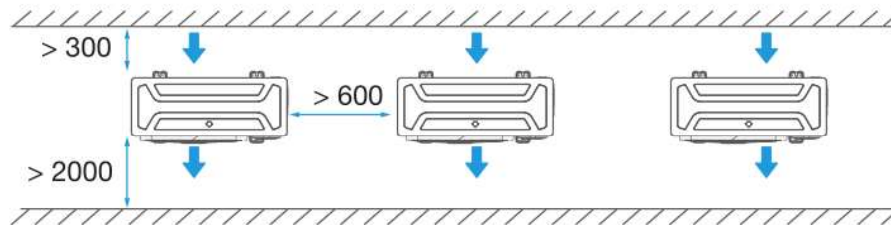
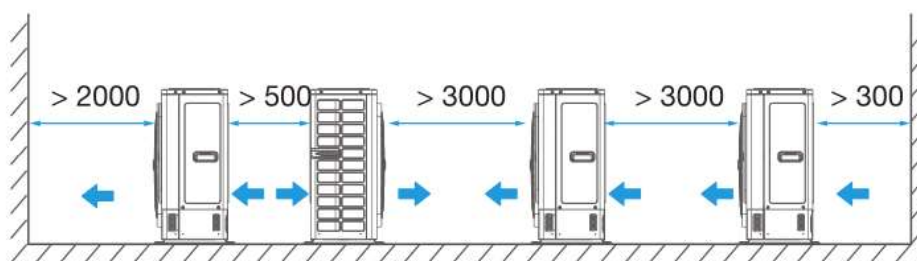

Figure 3-2.3: Parallel connect the front with rear sides (unit: mm)



2.1.3 Base structures

Outdoor unit base structure design should take account of the following considerations:

- A solid base prevents excess vibration and noise. Outdoor unit bases should be constructed on solid ground or on structures of sufficient strength to support the units' weight.
- Bases should be at least 200mm high to provide sufficient access for installation of piping.
- Either steel or concrete bases may be suitable.
- A typical concrete base design is shown in Figure 3-2.4. A typical concrete specification is 1 part cement, 2 parts sand and 6 parts crushed stone with $\Phi 10$ mm steel reinforcing bar. The edges of the base should be chamfered.
- To ensure that all contact points are equally secure, bases should be completely level. Base design should ensure that the points on the units' bases designed for weight-bearing support are fully supported.
- A drainage ditch should be provided to allow drainage of condensate that may form on the heat exchangers when the units are running in heating mode. The drainage should ensure that condensate is directed away from roadways and footpaths, especially in locations where the climate is such that condensate may freeze.

Figure 3-2.4: Outdoor unit typical concrete base structure design (unit: mm)

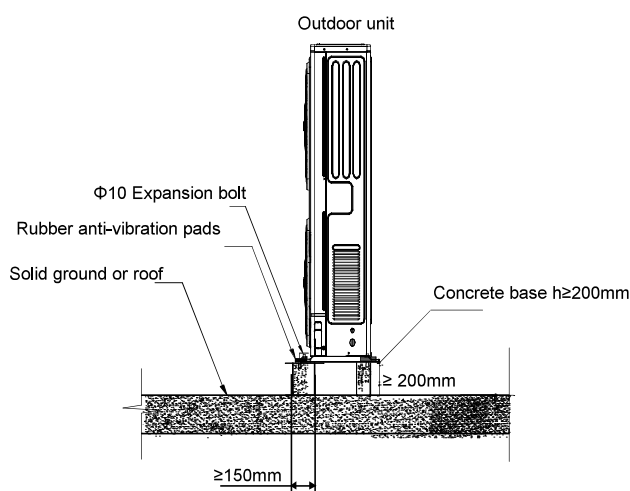

2.1.4 Centralized drainage

While installing the outdoor unit, pay attention to the installation place and the drainage pattern; if it's installed at the alpine zone, the frozen condensed water will block up the water outlet, please pull out the rubber stopper of the reserve water outlet. If that still fails to satisfy for the water draining, please knock open the other two water outlets, and keep the water can drain in time.

Pay attention to the knock the reserve water outlet from outside to inside, and it will be beyond repair after knocking open, please pay attention to the installation place, lest cause the inconvenience. Please do the moth proofing for the knocked out hole, to avoid the pest processing into and destroy the components.

Figure 3-2.8: Centralized drainage

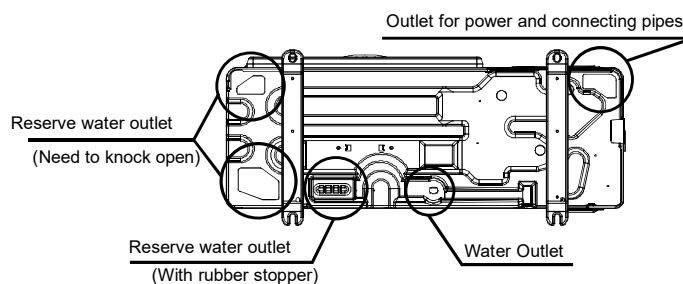

2.1.5 Acceptance and unpacking

Notes for installers



- When units are delivered check whether any damage occurred during shipment. If there is damage to the surface or outside of a unit, submit a written report to the shipping company.
- Check that the model, specifications and quantity of the units delivered are as ordered.
- Check that all accessories ordered have been included. Retain the Owner's Manual for future reference.

2.1.6 Hoisting

Notes for installers



- Do not remove any packaging before hoisting. If units are not packaged or if the packaging is damaged, use suitable boards or packing material to protect the units.
- Hoist one unit at a time, using two ropes to ensure stability.
- Keep units upright during hoisting, ensuring that the angle to the vertical does not exceed 30°.

2.2 Indoor Units

2.2.1 Placement considerations

Placement of indoor units should take account of the following considerations:

- Sufficient space for drain piping and for access during servicing and maintenance should be allowed.
- To ensure a good cooling/heating effect, short-circuit ventilation (where outlet air returns quickly to a unit's air inlet) should be avoided.
- To prevent excessive noise or vibration during operation, suspension rods or other weight-bearing fixings should typically be able to bear twice the unit's weight.

Notes for installers



- Before installing an indoor unit, check that the model to be installed is as specified in the construction drawings and confirm the correct orientation of the unit.
- Ensure that units are installed at the correct height.
- To allow smooth condensate drainage and to ensure unit stability (to prevent excessive noise or vibration), ensure that units are level to within 1° of the horizontal. If a unit is not level to within 1° of the horizontal, water leakage or abnormal vibration/noise may occur.

3 Refrigerant Piping Design

3.1 Design Considerations

Refrigerant piping design should take account of the following considerations:

- The amount of brazing required should be kept to a minimum.
- On the two inside sides of the first indoor branch joint ("A" in Figures 3-3.4 and Figure 3-3.5) the system should, as far as possible, be equal in terms of number of units, total capacities and total piping lengths.

3.2 Material Specification

Only seamless phosphorus-deoxidized copper piping that complies with all applicable legislation should be used. Temper grades and minimum thicknesses for different diameters of piping are specified in Table 3-3.1.

Table 3-3.1: Piping temper and thickness

Piping outer diameter (mm)	Temper ¹	Minimum thickness (mm)
Φ6.35	O (annealed)	0.8
Φ9.53		0.8
Φ12.7		0.8
Φ15.9		1.0
Φ19.1		1.0
Φ22.2	1/2H (half hard)	1.2
Φ25.4		1.2
Φ28.6		1.3
Φ31.8		1.5
Φ38.1		1.5
Φ41.3		1.5
Φ44.5		1.5
Φ54.0		1.8

Notes:

1. O: coiled piping;
2. 1/2H: straight piping.

3.3 Connection Method

Various piping patterns can be selected, such as out from the front, the back the side, and undersurface, etc. (The follow display the locations of several piping and wiring knock-off interfaces)

Table 3-3.2: The indoor and outdoor connecting pipe interface

Front out pipe	Side out pipe	Back out pipe
Undersurface out pipe	The connect method of flaring	
	<p>Connecting Pipe (Accessory)</p> <p>Front out pipe</p> <p>Back out pipe</p> <p>Side out pipe</p> <p>Bottom out pipe</p> <p>For the 48kBtu/h outdoor unit's back out pipe connection, connecting pipe is suggested to be used. For the 56kBtu/h outdoor unit's, connecting pipe is suggested to be used in all directions out pipe connection.</p>	

3.4 The Permitted Piping Lengths and Level Differences

The piping length and level difference requirements that apply are summarized in Table 3-3.2 and are fully described as follows (refer to Figure 3-3.1 and Figure 3-3.3):

Figure 3-3.1: The first connecting method (Welding)

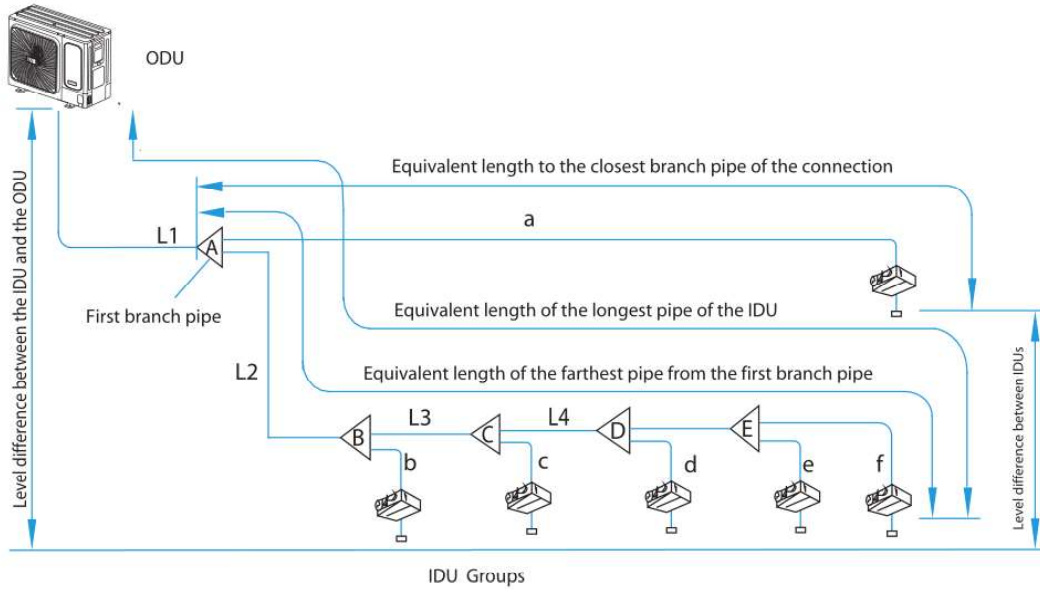

Figure 3-3.2: The second connecting method (Welding)

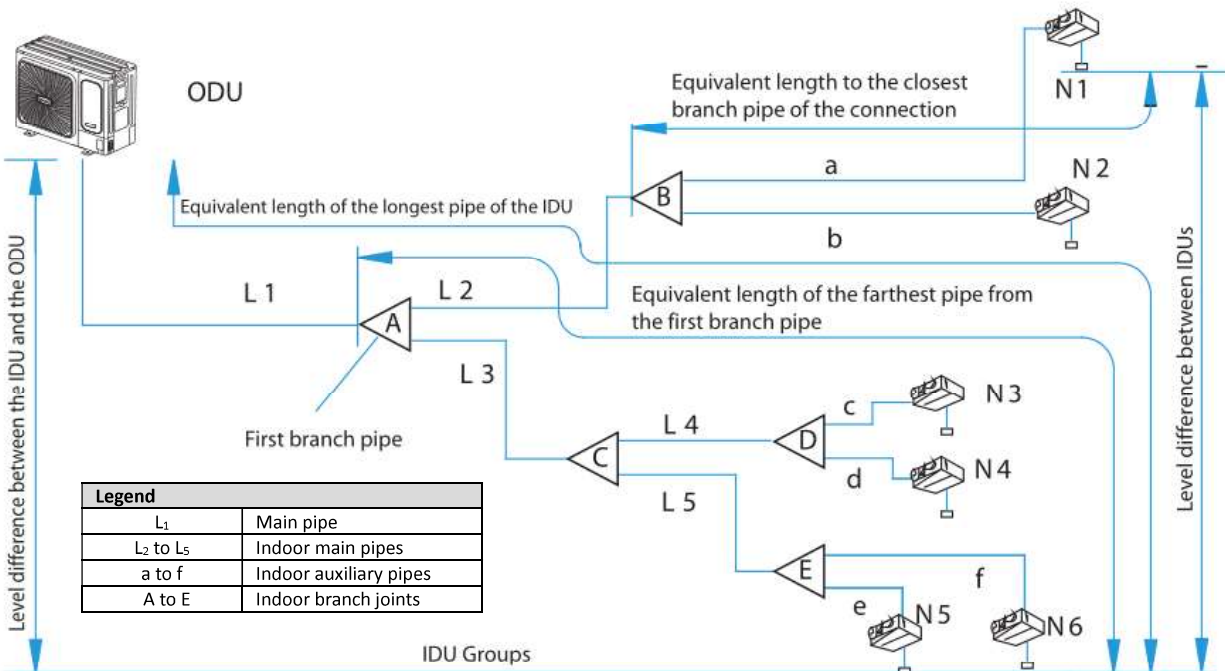

Figure 3-3.3: The third connecting method (Flaring)

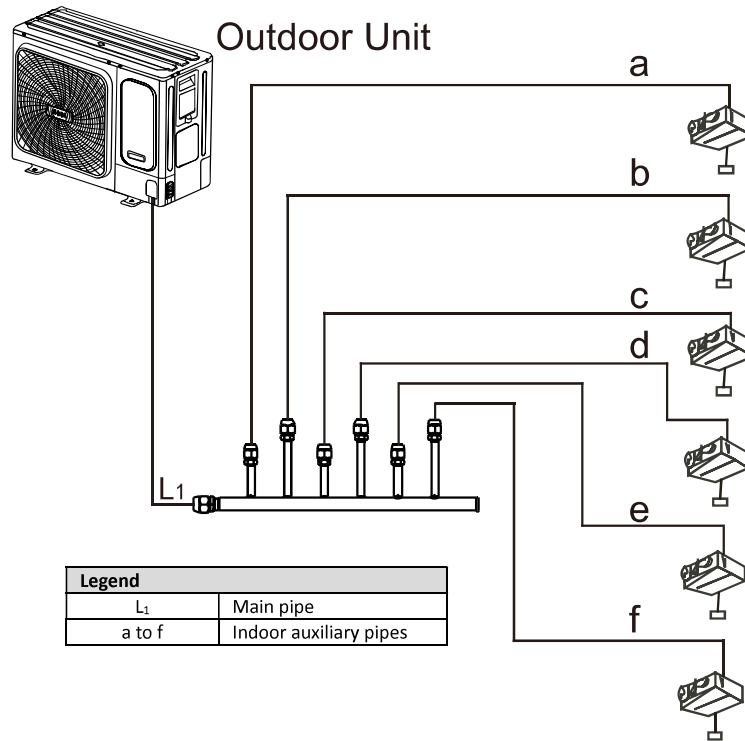

Table 3-3.2: Summary of permitted refrigerant piping lengths and level differences

		Permitted value	Piping	
Pipe Length	Total Pipe Length(Actual)	≤100m	L1+L2+L3+L4+L5+a+b+c+d+e+f	
	Maximum Piping	Actual Length	≤45m(30/40/50 model) ≤60m(60/70model)	L1+L2+L3+L4+L5+f (The first connecting method) or L1+L3+L5+f (The second connecting method) or L1+a (The third connecting method)
		Equivalent Length	≤50m(30/40/50 model) ≤70m(60/70 model)	
	Pipe Length (from the first branch to the furthest IDU)	≤20m	L2+L3+L4+L5+f(The first connecting method) or L3+L5+f(The second connecting method)	
	Pipe Length(IDU to the nearest branch)	≤15m	a,b,c,d,e,f	
Level difference	Level difference between IDU~ODU	Outdoor Unit Up	≤30m	----
		Outdoor Unit Down	≤20m	----
	Level difference between IDU~IDU	≤10m	----	

Table 3-3.3: Connectable indoor units

Outdoor unit model	Number of connected indoor units	Connectable indoor unit capacity range
BCSF030N0A4-DTM090	1-4	45-130% outdoor unit's capacity
BCSF040N0A6-DTM115	1-6	
BCSF050N0A7-DTM140	1-7	
BCSF060N0A8-DTM160	1-8	
BCSF070N0A9-DTM190	1-9	

3.5 Selecting Piping Diameters

Tables 3-3.4 to 3-3.6 below, specify the required pipe diameters for the indoor and outdoor piping. The main pipe (L₁) and first indoor branch joint (A) should be sized according to whichever of Tables 3-3.4 and 3-3.5 indicates the larger size.

Figure 3-3.4: Selecting piping diameters

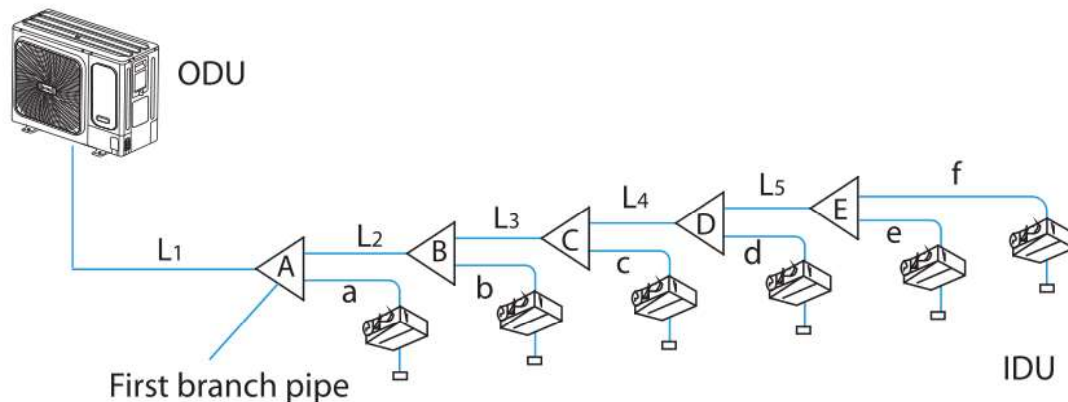

Legend		
L ₁	Main pipe	Figures in parentheses indicate indoor unit capacity indexes.
L ₂ to L ₅	Indoor main pipes	
a to f	Indoor auxiliary pipes	
A to E	Indoor branch joints	

Table 3-3.4: Main pipe¹ (L₁) indoor main pipes (L₂ to L₅) and indoor branch joint kits

Capacity of indoor unit (A×10W)	Gas pipe (mm)	Liquid pipe (mm)	Branch joint kit
A<160	Φ15.9	Φ9.53	BABH002NF-D2
160≤A<230	Φ19.1	Φ9.53	BABH002NF-D2

Notes:

1. The main pipe (L₁) and first indoor branch joint (A) should be sized according to whichever of Tables 3-3.4 and 3-3.5 indicates the larger size.

Table 3-3.5: Main pipe¹ (L₁) and first indoor branch joint (A)

Capacity of outdoor unit (A×10W)	Equivalent length of all liquid pipes and gas pipes < 90m			Equivalent length of all liquid pipes and gas pipes ≥ 90m		
	Gas pipe (mm)	Liquid pipe (mm)	Branch joint kit	Gas pipe (mm)	Liquid pipe (mm)	Branch joint kit
A<155	Φ15.9	Φ9.53	BABH002NF-D2	Φ19.1	Φ9.53	BABH002NF-D2
155≤A<230	Φ19.1	Φ9.53	BABH002NF-D2	Φ22.2	Φ9.53	BABH003NF-D3

Notes:

1. The main pipe (L₁) and first indoor branch joint (A) should be sized according to whichever of Tables 3-3.4 and 3-3.5 indicates the larger size.
2. The straight distance between copper pipe turning and the contiguous branch pipe is at least 0.5 m.
3. The straight distance between the contiguous branch pipes is at least 0.5 m.
4. The straight distance which the branch pipes connected to the IDU is at least 0.5 m.

Table 3-3.6: Indoor auxiliary pipes (a to f)

Capacity of indoor unit (A×100W)	Gas pipe (mm)	Liquid pipe (mm)
A≤45	Φ12.7	Φ6.35
A≥56	Φ15.9	Φ9.53

Table 3-3.7: Pipe diameter of the outdoor unit

Outdoor unit model	Gas pipe (mm)	Liquid pipe (mm)
BCSF030N0A4-DTM090	Φ15.9	Φ9.53
BCSF040N0A6-DTM115		
BCSF050N0A7-DTM140		
BCSF060N0A8-DTM160		
BCSF070N0A9-DTM190		

3.6 Refrigerant Piping Selection Example

The example below illustrates the piping selection procedure for a system consisting of one outdoor unit (16kW) and 6 indoor units. The system's equivalent length of all liquid pipes and gas pipes is in excess of 90m.

Figure 3-3.5: Refrigerant piping selection example

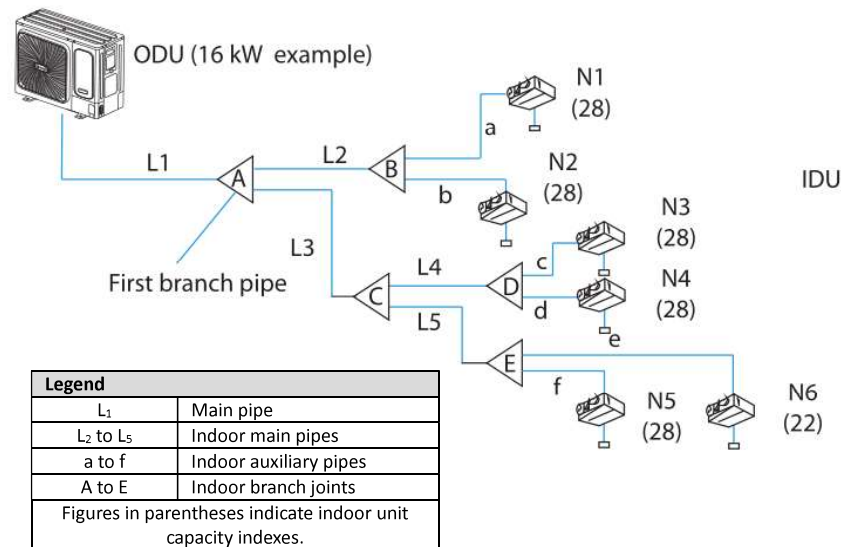

Step 1: Select indoor auxiliary pipes

- Indoor units N₁~ N₅ are of capacity 2.8kW, N₆ is 2.2kW. Refer to Table 3-3.6. Indoor auxiliary pipes a, b, c, d, e, f is $\Phi 12.7 / \Phi 6.35$.

Step 2: Select indoor main pipes and indoor branch joints B to E

- The indoor units (N₁ and N₂) downstream of indoor branch joint B have total capacity of $28 \times 2 = 56$. Refer to Table 3-3.4. Indoor main pipe L₂ is $\Phi 15.9 / \Phi 9.53$. Indoor branch joint B is BABH002NF-D2.
- The indoor units (N₃ and N₄) downstream of indoor branch joint D have total capacity of $28 \times 2 = 56$. Refer to Table 3-3.4. Indoor main pipe L₄ is $\Phi 15.9 / \Phi 9.53$. Indoor branch joint D is BABH002NF-D2.
- The indoor units (N₅ and N₆) downstream of indoor branch joint E have total capacity of $22+28 = 50$. Refer to Table 3-3.4. Indoor main pipe L₅ is $\Phi 15.9 / \Phi 9.53$. Indoor branch joint E is BABH002NF-D2.
- The indoor units (N₃ to N₆) downstream of indoor branch joint C have total capacity of $28 \times 3 + 22 = 106$. Refer to Table 3-3.4. Indoor main pipe L₃ is $\Phi 15.9 / \Phi 9.53$. Indoor branch joint C is BABH002NF-D2.

Step 3: Select main pipe and indoor branch joint A

- The indoor units (N₁ to N₆) downstream of indoor branch joint A have total capacity of $28 \times 5 + 22 = 162$. The system's equivalent length of all liquid pipes and gas pipes is in excess of 90m. The capacity of the outdoor unit is 16kW. Refer to Tables 3-3.4 and 3-3.5. Main pipe L₁ is $\Phi 22.2 / \Phi 9.53$, Indoor branch joint A is BABH003NF-D3.

3.7 Branch Joints

Branch joint design should take account of the following:

- U-shaped branch joints should be used – tee joints are not suitable. Branch joint dimensions are given in Tables 3-3.7.
- To ensure even distribution of refrigerant, branch joints should not be installed within 500mm of a 90° bend, another branch joint or the straight section of piping leading to an indoor unit, with the minimum 500mm being measured from the point where the branch joint is connected to the piping, as shown in Figure 3-3.6.

Figure 3-3.6: Branch joint spacing and separation from bends (unit: mm)

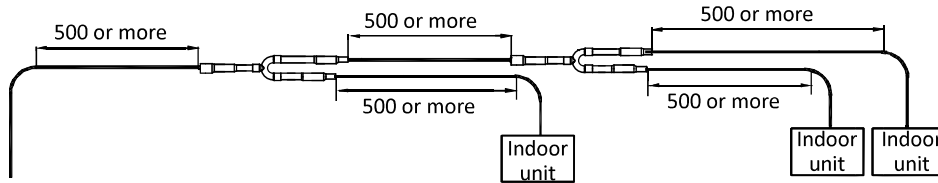

Table 3-3.8: Indoor branch joint dimensions (unit: mm)

Model	Gas side joints	Liquid side joints
BABH002NF-D2		
BABH003NF-D3		

3.8 Refrigerant Leakage Precautions

R410A refrigerant is not flammable in air at temperatures up to 100°C at atmospheric pressure and is generally considered a safe substance to use in air conditioning systems. Nevertheless, precautions should be taken to avoid danger to life in the unlikely event of a major refrigerant leakage. Precautions should be taken in accordance with all applicable legislation. Where no applicable legislation exists, the following may be used as a guide:

- Air conditioned rooms should be large enough that if leakage of all the refrigerant in the system occurs, the concentration of the refrigerant in the room does not reach a level dangerous to health.
- A critical concentration (at which point R410A becomes dangerous to human health) of 0.3 kg/m³ can be used.
- The potential concentration of refrigerant in a room following a leak can be calculated as follows:
 - Calculate the total amount in of refrigerant in the system (“A”) as the nameplate charge (the charge in the system when delivered from the factory) plus the additional charge added as per Part 3, 7.1 “Calculating Additional Refrigerant Charge”.
 - Calculate the total volume (“B”) of the smallest room into which refrigerant could potentially leak.
 - Calculate the potential refrigerant concentration as A divided by B.
 - If A/B is not less than 0.3 kg/m³, countermeasures such installing mechanical ventilators (either ventilating regularly or controlled by refrigerant leakage detectors) should be taken.
- Since R410A is heavier than air, particular consideration should be given to leak scenarios in basement rooms.

Figure 3-3.7: Potential refrigerant leak scenario

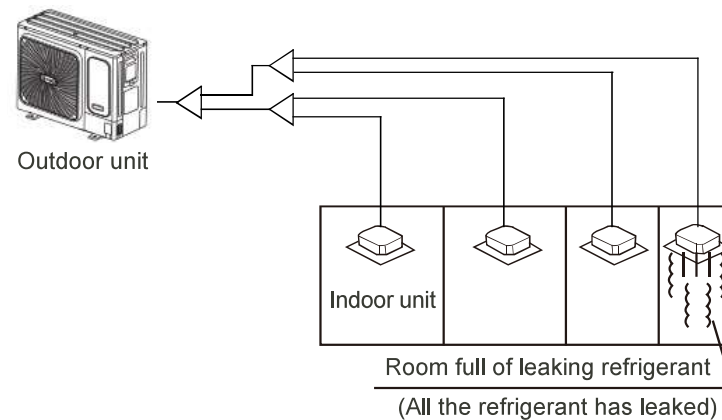
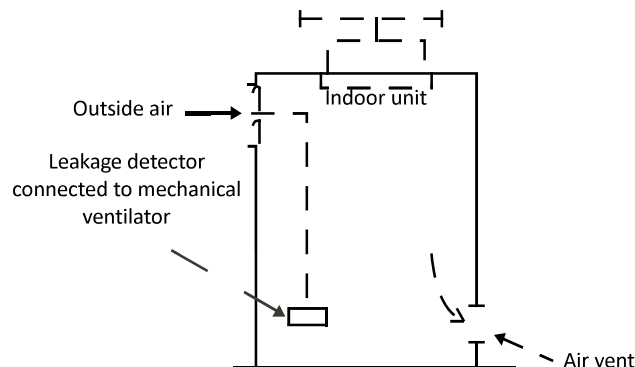

Figure 3-3.8: Mechanical ventilator controlled by refrigerant leak detector



4 Refrigerant Piping Installation

4.1 Procedure and Principles

4.1.1 Installation procedure

Notes for installers



Installation of the refrigerant piping system should proceed in the following order:



Note: Pipe flushing should be performed once the brazed connections have been completed with the exception of the final connections to the indoor units. That is, flushing should be performed once the outdoor unit have been connected but before the indoor units are connected.

4.1.2 Three principles for refrigerant piping

	Reasons	Measures
CLEAN	Particles such as oxide produced during brazing and/or building dust can lead to compressor malfunction	<ul style="list-style-type: none"> Seal piping during storage¹ Flow nitrogen during brazing² Pipe flushing³
DRY	Moisture can lead to ice formation or oxidization of internal components leading to abnormal operation or compressor damage	<ul style="list-style-type: none"> Pipe flushing³ Vacuum drying⁴
SEALED	Imperfect seals can lead to refrigerant leakage	<ul style="list-style-type: none"> Pipe manipulation⁵ and brazing² techniques Gas tightness test⁶

Notes:

- See Part 3, 4.2.1 "Pipe delivery, storage and sealing".
- See Part 3, 4.5 "Brazing".
- See Part 3, 4.7 "Pipe Flushing".
- See Part 3, 4.9 "Vacuum Drying".
- See Part 3, 4.3 "Manipulating Copper Piping".
- See Part 3, 4.8 "Gastightness Test".

4.2 Storing Copper Piping

4.2.1 Pipe delivery, storage and sealing

Notes for installers



- Ensure that piping does not get bent or deformed during delivery or whilst stored.
- On construction sites store piping in a designated location.
- To prevent dust or moisture entering, piping should be kept sealed whilst in storage and until it is about to be connected. If piping is to be used soon, seal the openings with plugs or adhesive tape. If piping is to be stored for a long time, charge the piping with nitrogen at 0.2-0.5MPa and seal the openings by brazing.
- Storing piping directly on the ground risks dust or water ingress. Wooden supports can be used to raise piping off the ground.
- During installation, ensure that piping to be inserted through a hole in a wall is sealed to ensure dust and/or fragments of wall do not enter.
- Be sure to seal piping being installed outdoors (especially if being installed vertically) to prevent rain entering.

4.3 Manipulating Copper Piping

4.3.1 De-oiling

Notes for installers



- Lubrication oil used during some copper pipe manufacturing processes can cause deposits to form in R410A refrigerant systems, causing system errors. Oil-free copper piping should therefore be selected. If ordinary (oily) copper piping is used, it must be cleaned with gauze dipped in tetrachloroethylene solution prior to installation.

Caution

- Never use carbon tetrachloride (CCl₄) for pipe cleansing or flushing, as doing so will seriously damage the system.

4.3.2 Cutting copper piping and removing burrs

Notes for installers



- Use a pipe cutter rather than a saw or cutting machine to cut piping. Rotate the piping evenly and slowly, applying even force to ensure that the piping does not become deformed during cutting. Using a saw or cutting machine to cut piping runs the risk of copper shavings entering the piping. Copper shavings are difficult to remove and pose a serious risk to the system if they enter the compressor or block the throttling unit.
- After cutting using a pipe cutter, use a reamer/scrapper to remove any burrs that have formed at the opening, keeping the opening of the piping downwards to avoid copper shavings from entering the piping.
- Remove burrs carefully to avoid scratches, which may prevent a proper seal being formed and lead to refrigerant leakage.

4.3.3 Expanding copper piping ends

Notes for installers



- Ends of copper piping can be expanded so that another length of piping can be inserted and the joint brazed.
- Insert the expanding head of the pipe expander into the pipe. After completing pipe expansion, rotate the copper pipe a few degrees to rectify the straight line mark left by the expanding head.

Caution

- Ensure that the expanded section of piping is smooth and even. Remove any burrs that remain after cutting.

Figure 3-4.1: Expanding copper piping ends

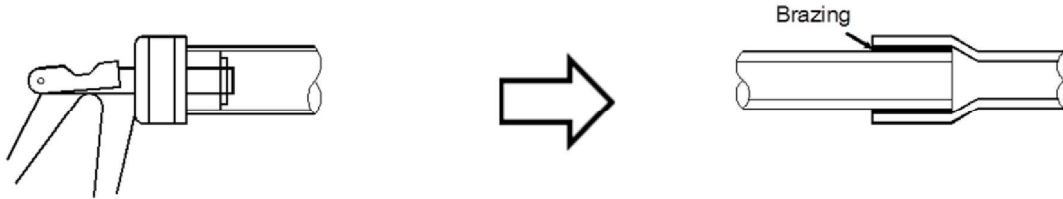

4.3.4 Flared joints

Flared joints should be used where a screw thread connection is required.

Notes for installers



- Before flaring 1/2H (half hard) piping, anneal the end of the pipe to be flared.
- Remember to place the flare nut on the piping before flaring.
- Ensure the flared opening is not cracked, deformed or scratched, otherwise it will not form a good seal and refrigerant leakage may occur.
- The diameter of the flared opening should be within the ranges specified in Table 3-4.1. Refer to Figure 3-4.2.

Table 3-4.1: Flared opening size ranges

Pipe (mm)	Flared opening diameter (A) (mm)
Φ6.35	8.3 - 8.7
Φ9.53	12.0 - 12.4
Φ12.7	15.4 - 15.8
Φ15.9	18.6 - 19.0
Φ19.1	22.9 - 23.3

Figure 3-4.2: Flared opening

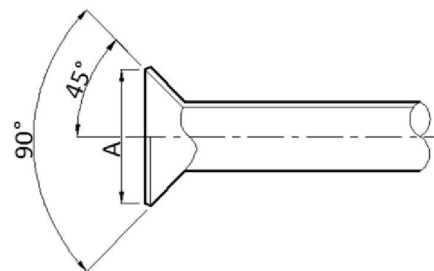

- When connecting a flared joint, apply some compressor oil to the inner and outer surfaces of the flared opening to facilitate the connection and rotation of the flare nut, ensure firm connection between the sealing surface and the bearing surface, and avoid the pipe becoming deformed.

4.3.5 Bending piping

Bending copper piping reduces the number of brazed joints required and can improve quality and save material.

Notes for installers



Piping bending methods

- Hand bending is suitable for thin copper piping ($\Phi 6.35\text{mm} - \Phi 12.7\text{mm}$).
- Mechanical bending (using a bending spring, manual bending machine or powered bending machine) is suitable for a wide range of diameters ($\Phi 6.35\text{mm} - \Phi 54.0\text{mm}$).

Caution

- When using a spring bender, ensure that the bender is clean before inserting it in the piping.
- After bending a copper pipe, ensure that there are no wrinkles or deformation on either side of the pipe.
- Ensure that bend angles do not exceed 90° , otherwise wrinkles may appear on the inner side of the pipe, and the pipe may buckle or crack. Refer to Figure 3-4.3.
- Do not use a pipe that has buckled during the bending process; ensure that the cross section at the bend is greater than $2/3$ of the original area.

Figure 3-4.3: Pipe bending in excess of 90°

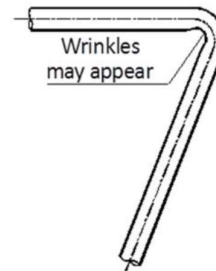

4.4 Refrigerant Piping Supports

When the air conditioner is running, the refrigerant piping will deform (shrink, expand, droop). To avoid damage to piping, hangers or supports should be spaced as per the criteria in the Table 3-4.2. In general, the gas and liquid pipes should be suspended in parallel and the interval between support points should be selected according to the diameter of the gas pipe.

Table 3-4.2: Refrigerant piping support spacings

Pipe (mm)	Interval between support points (m)	
	Horizontal Piping	Vertical Piping
< $\Phi 20$	1	1.5
$\Phi 20 - \Phi 40$	1.5	2
> $\Phi 40$	2	2.5

Suitable insulation should be provided between the piping and the supports. If wooden dowels or blocks are to be used, use wood that has undergone preservative treatment.

Changes in refrigerant flow direction and refrigerant temperature result in movement, expansion and shrinkage of the refrigerant piping. Piping should therefore not be fixed too tightly, otherwise stress concentrations may occur in the piping, with the potential for rupturing.

4.5 Brazing

Care must be taken to prevent oxide forming on the inside of copper piping during brazing. The presence of oxide in a refrigerant system adversely affects the operation of valves and compressors, potentially leading to low efficiency or even compressor failure. To prevent oxidation, during brazing nitrogen should be flowed through the refrigerant piping.

Notes for installers



Warning

- Never flow oxygen through piping as doing so aids oxidation and could easily lead to explosion and as such is extremely dangerous.
- Take appropriate safety precautions such as having a fire extinguisher to hand whilst brazing.

Flowing nitrogen during brazing

- Use a pressure reducing valve to flow nitrogen through copper piping at 0.02-0.03MPa during brazing.
- Start the flow before brazing starts and ensure that the nitrogen continuously passes through the section being brazed until the brazing is complete and the copper has cooled down completely.

Figure 3-4.4: Flowing nitrogen through piping during brazing

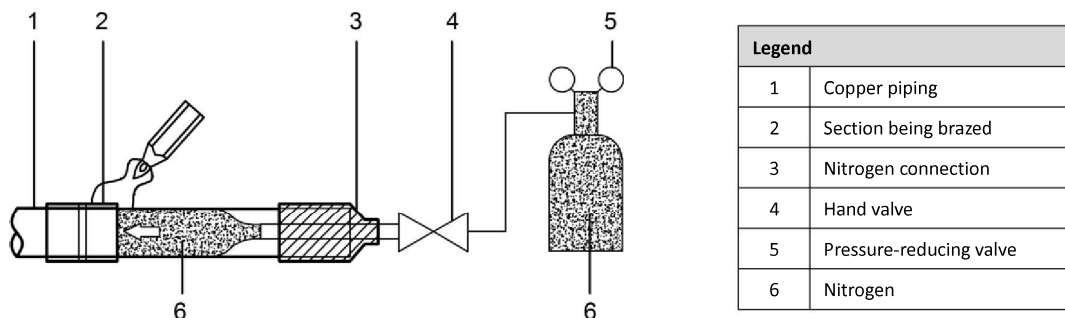

- When joining a shorter section of piping to a longer section, flow nitrogen from the shorter side to allow better displacement of air with nitrogen.
- If the distance from the point where nitrogen enters the piping to the joint to be brazed is long, ensure that the nitrogen is flowed for sufficient time to discharge all the air from the section to be brazed before commencing brazing.

Figure 3-4.5: Flowing nitrogen from shorter side during brazing

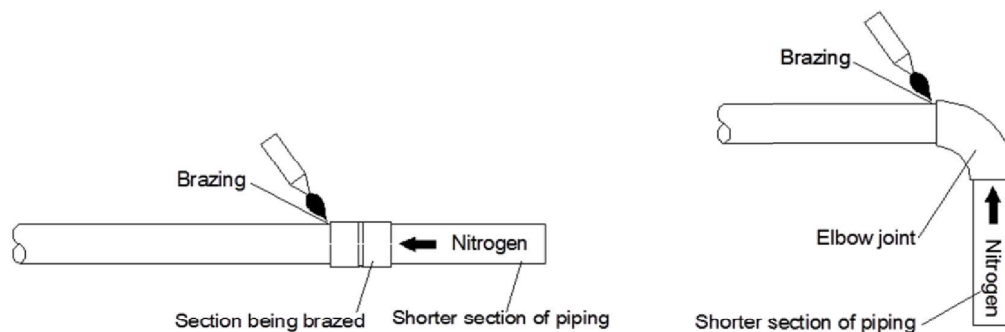

Box continued on next page ...

Piping orientation during brazing

Brazing should be conducted downwards or horizontally to avoid filler leakage.

Figure 3-4.6: Piping orientation during brazing

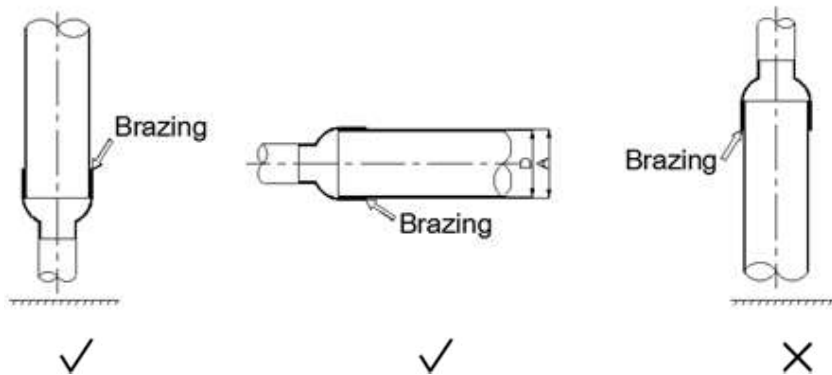

Piping overlap during brazing

Table 3-4.3 specifies the minimum permissible piping overlap and the range of permissible gap sizes for brazed joints on piping of different diameters. Refer also to Figure 3-4.7.

Figure 3-4.7: Piping overlap and gap for brazed joints

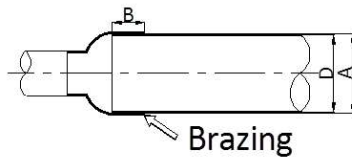

Legend	
A	Inner diameter of larger pipe
D	Outer diameter of smaller pipe
B	Inlaid depth (overlap)

Table 3-4.3: Piping overlap and gap for brazed joints¹

D (mm)	Minimum permissible B (mm)	Permissible A – D (mm)
5 < D < 8	6	0.05 - 0.21
8 < D < 12	7	
12 < D < 16	8	0.05 - 0.27
16 < D < 25	10	
25 < D < 35	12	0.05 - 0.35
35 < D < 45	14	

Notes:

1. A, B, D refer to the dimensions shown in Figure 3-4.7.

Filler

- Use a copper/phosphorus brazing alloy (BCuP) filler that does not require flux.
- Do not use flux. Flux can cause corrosion of piping and can affect the performance of compressor oil.
- Do not use anti-oxidants when brazing. Residue can clog piping and damage components.

4.6 Branch Joints

Notes for installers



- Use U-shaped branch joints as specified on the construction drawings – do not replace U-shaped branch joints with tee joints.
- Indoor branch joints may be installed either horizontally or vertically. Horizontal branch joints must be installed at an angle to the horizontal not exceeding 10° in order to avoid uneven distribution of refrigerant and possible malfunction. Refer to Figure 3-4.8.
- To ensure even distribution of refrigerant, a limitation is placed on how close branch joints may be installed to bends, other branch joints and the straight sections of piping leading to indoor units. Refer to Part 3, 3.7 “Branch Joints”.

Figure 3-4.8: Branch joint orientation

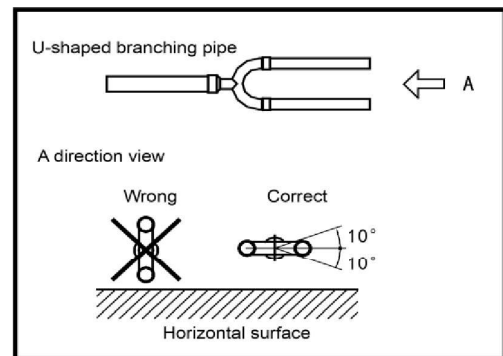

4.7 Pipe Flushing

4.7.1 Purpose

To remove dust, other particles and moisture, which could cause compressor malfunction if not flushed out before the system is run, the refrigerant piping should be flushed using nitrogen. As described in Part 3, 4.1.1 “Installation procedure”, pipe flushing should be performed once the piping connections have been completed with the exception of the final connections to the indoor units. That is, flushing should be performed once the outdoor units have been connected but before the indoor units are connected.

4.7.2 Procedure

Notes for installers



Warning

Only use nitrogen for flushing. Using carbon dioxide risks leaving condensation in the piping. Oxygen, air, refrigerant, flammable gases and toxic gases must not be used for flushing. Use of such gases may result in fire or explosion.

Procedure

The liquid and gas sides can be flushed simultaneously; alternatively, one side can be flushed first and then Steps 1 to 8 repeated, for the other side. The flushing procedure is as follows:

1. Cover the inlets and outlets of the indoor units to prevent dirt getting blown in during pipe flushing. (Pipe flushing should be carried out before connecting the indoor units to the piping system.)
2. Attach a pressure reducing valve to a nitrogen cylinder.
3. Connect the pressure reducing valve outlet to the inlet on the liquid (or gas) side of the outdoor unit.
4. Use blind plugs to block all liquid (gas) side openings, except for the opening at the indoor unit which is furthest from the outdoor unit ("Indoor unit A" in Figure 3-4.9).
5. Start to open the nitrogen cylinder valve and gradually increase the pressure to 0.5MPa.
6. Allow time for nitrogen to flow as far as the opening at indoor unit A.
7. Flush the first opening:
 - a) Using suitable material, such as a bag or cloth, press firmly against the opening at indoor unit A.
 - b) When the pressure becomes too high to block with your hand, suddenly remove your hand allowing gas to rush out.
 - c) Repeatedly flush in this manner until no further dirt or moisture is emitted from the piping. Use a clean cloth to check for dirt or moisture being emitted. Seal the opening once it has been flushed.
8. Flush the other openings in the same manner, working in sequence from indoor unit A towards the outdoor unit. Refer to Figure 3-4.10.
9. Once flushing is complete, seal all openings to prevent dust and moisture from entering.

Figure 3-4.9: Pipe flushing using nitrogen

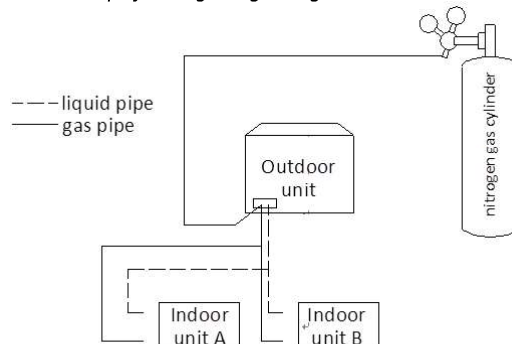
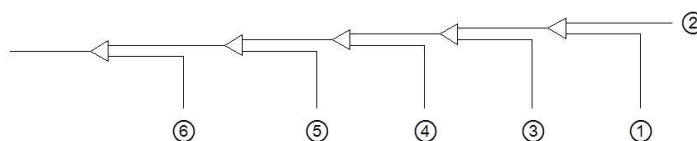

Figure 3-4.10: Pipe flushing sequence¹



Notes:

1. 1-2-3-4-5-6 working towards the outdoor unit.

4.8 Gastightness Test

4.8.1 Purpose

To prevent faults caused by refrigerant leakage, a gastightness test should be performed before system commissioning.

4.8.2 Procedure

Notes for installers



Warning

Only dry nitrogen should be used for gastightness testing. Oxygen, air, flammable gases and toxic gases must not be used for gastightness testing. Use of such gases may result in fire or explosion.

Procedure

The gastightness test procedure is as follows:

Step 1

- Once the piping system is complete and the indoor and outdoor units have been connected, vacuum the piping to -0.1MPa.

Step 2

- Charge the indoor piping with nitrogen at 0.3MPa through the needle valves on the liquid and gas stop valves and leave for at least 3 minutes (do not open the liquid or gas stop valves). Observe the pressure gauge to check for large leakages. If there is a large leakage, the pressure gauge will drop quickly.
- If there are no large leakages, charge the piping with nitrogen at 1.5MPa and leave for at least 3 minutes. Observe the pressure gauge to check for small leakages. If there is a small leakage, the pressure gauge will drop distinctly.
- If there are no small leakages, charge the piping with nitrogen at 4.0MPa and leave for at least 24 hours to check for micro leakages. Micro leakages are difficult to detect. To check for micro leakages, allow for any change in ambient temperature over the test period by adjusting the reference pressure by 0.01MPa per 1°C of temperature difference. Adjusted reference pressure = Pressure at pressurization + (temperature at observation – temperature at pressurization) x 0.01MPa. Compare the observed pressure with the adjusted reference pressure. If they are the same, the piping has passed the gastightness test. If the observed pressure is lower than the adjusted reference pressure, the piping has a micro leakage.
- If the leakage is detected, refer to Part 3, 4.8.3 “Leak detection”. Once the leak has been found and fixed, the gastightness test should be repeated.

Step 3

- If not continuing straight to vacuum drying (see Part 3, 4.9 “Vacuum Drying”) once the gastightness test is complete, reduce the system pressure to 0.5-0.8MPa and leave the system pressurized until ready to carry out the vacuum drying procedure.

Figure 3-4.11: Gastightness test

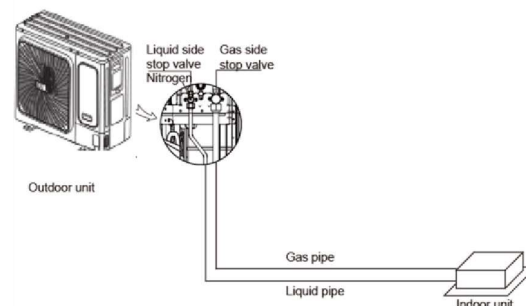

4.8.3 Leak detection

Notes for installers



The general methods for identifying the source of a leak are as follows:

1. Audio detection: relatively large leaks are audible.
2. Touch detection: place your hand at joints to feel for escaping gas.
3. Soapy water detection: small leaks can be detected by the formation of bubbles when soapy water is applied to a joint.
4. Refrigerant leak detection: for leaks that are difficult to detect, refrigerant leak detection may be used as follows:
 - a) Pressurize the piping with nitrogen at 0.3MPa.
 - b) Add refrigerant into the piping until the pressure reaches 0.5MPa.
 - c) Use a halogen refrigerant detector to find the leak.
 - d) If the leak source cannot be found, continuing charging with refrigerant to a pressure of 4MPa and then search again.

4.9 Vacuum Drying

4.9.1 Purpose

Vacuum drying should be performed in order to remove moisture and non-condensable gases from the system. Removing moisture prevents ice formation and oxidization of copper piping or other internal components. The presence of ice particles in the system would cause abnormal operation, whilst particles of oxidized copper can cause compressor damage. The presence of non-condensable gases in the system would lead to pressure fluctuations and poor heat exchange performance.

Vacuum drying also provides additional leak detection (in addition to the gas tightness test).

4.9.2 Procedure

Notes for installers



During vacuum drying, a vacuum pump is used to lower the pressure in the piping to the extent that any moisture present evaporates. At 5mmHg (755mmHg below typical atmospheric pressure) the boiling point of water is 0°C. Therefore a vacuum pump capable of maintaining a pressure of -756mmHg or lower should be used. Using a vacuum pump with a discharge in excess of 4L/s and a precision level of 0.02mmHg is recommended.

Caution

- Before performing vacuum drying, make sure that all the outdoor unit stop valves are firmly closed.
- Once the vacuum drying is complete and the vacuum pump is stopped, the low pressure in the piping could suck vacuum pump lubricant into the air conditioning system. The same could happen if the vacuum pump stops unexpectedly during the vacuum drying procedure. Mixing of pump lubricant with compressor oil could cause compressor malfunction and a one-way valve should therefore be used to prevent vacuum pump lubricant seeping into the piping system.

Procedure

The vacuum drying procedure is as follows:

Step 1

- Connect the blue (low pressure side) hose of a pressure gauge to the outdoor unit gas pipe stop valve, the red (high pressure side) hose to the outdoor unit liquid pipe stop valve and the yellow hose to the vacuum pump.

Step 2

- Start the vacuum pump and then open the pressure gauge valves to start vacuum the system.
- After 30 minutes, close the pressure gauge valves.
- After a further 5 to 10 minutes check the pressure gauge. If the gauge has returned to zero, check for leakages in the refrigerant piping.

Step 3

- Re-open the pressure gauge valves and continue vacuum drying for at least 2 hours and until a pressure difference of 756mmHg or more has been achieved. Once the pressure difference of at least 756mmHg has been achieved, continue vacuum drying for 2 hours.

Step 4

- Close the pressure gauge valves and then stop the vacuum pump.
- After 1 hour, check the pressure gauge. If the pressure in the piping has not increased, the procedure is finished. If the pressure has increased, check for leakages.
- After vacuum drying, **keep the blue and red hoses connected to the pressure gauge and to the outdoor unit stop valves**, in preparation for refrigerant charging (see Part 3, 7 “Charging Refrigerant”).

Figure 3-4.12: Vacuum drying

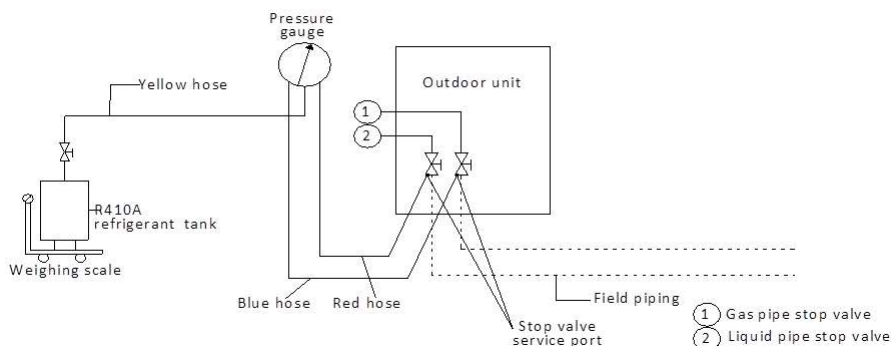

Pressure gauge

5 Drain Piping

5.1 Design Considerations

Drain piping design should take account of the following considerations:

- Indoor unit condensate drain piping needs to be of sufficient diameter to carry the volume of condensate produced at the indoor units and installed at a slope sufficient to allow drainage. Discharge as close as possible to the indoor units is usually preferable.
- To prevent the drain piping becoming excessively long, consideration should be given to installing multiple drain piping systems, with each system having its own drainage point and providing drainage for a subset of the overall set of indoor units.
- The routing of drain piping should take into consideration the need to maintain sufficient slope for drainage whilst avoiding obstacles such as beams and ducting. The drain piping slope should be at least 1:100 away from indoor units. Refer to Figure 3-5.1.

Figure 3-5.1: Drain piping minimum slope requirement

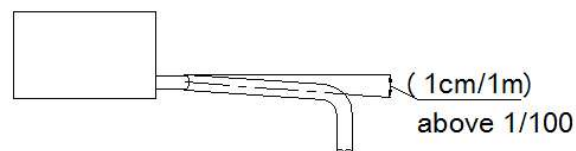

- To avoid backflow and other potential complications, two horizontal drain pipes should not meet at the same level. Refer to the Figure 3-5.2 for suitable connection arrangements. Such arrangements also allow the slope of the two horizontal pipes to be selected independently.

Figure 3-5.2: Drain piping joints – correct and incorrect configurations

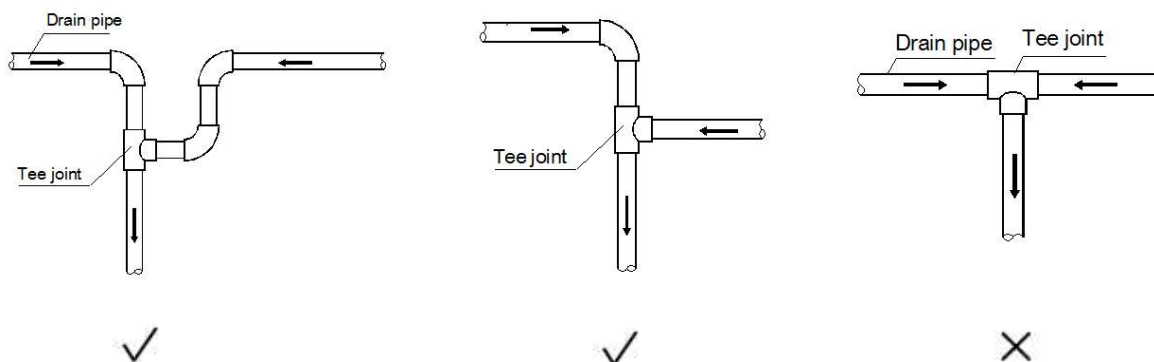

- Branch drain piping should join main drain piping from the top, as shown in Figure 3-5.3.
- Recommended support/hanger spacing is 0.8 – 1.0m for horizontal piping and 1.5 – 2.0m for vertical piping. Each vertical section should be fitted with at least two supports. For horizontal piping, spacing greater than those recommended leads to sagging and deformation of the pipe profile at the supports which impedes water flow and should therefore be avoided.
- Air vents should be fitted at the highest point of each drain piping system to ensure that condensation is discharged smoothly. U-bends or elbow joints should be used such that the vents face downwards, to prevent dust entering the piping. Refer to Figure 3-5.5. Air vents should not be

Figure 3-5.3: Branch drain piping joining main drain piping

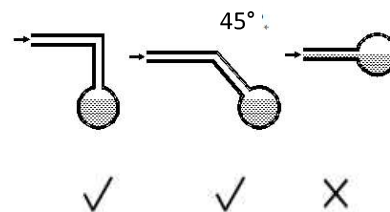
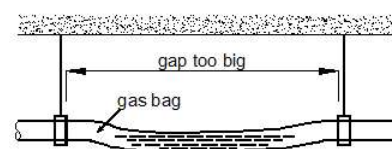
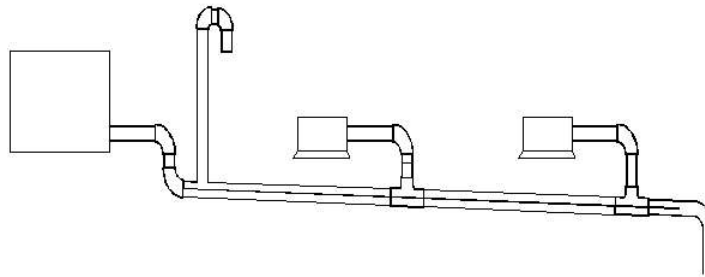

Figure 3-5.4: Effect of insufficient drain piping support



installed too close to indoor unit lift pumps.

Figure 3-5.5: Drain piping air vents



- Air conditioner drain piping should be installed separately from waste, rainwater and other drain piping and should not come into direct contact with the ground.
- Drain piping diameter should be not less than the indoor units' drain piping connection.
- To allow inspection and maintenance, the piping clamps shipped with units should be used to attach drain piping to indoor units – adhesive should not be used.
- Thermal insulation should be added to drain piping to prevent condensation forming. Thermal insulation should extend all the way to the connection with the indoor unit.
- Units with drain pumps should have separate drain piping systems from systems that use natural drainage.

5.2 Water Traps

For indoor units with a high negative pressure differential at the outlet of the drainage pan, a trap should be fitted to the drain piping to prevent poor drainage and/or water being blown back into the drainage pan. Traps should be arranged as in Figure 3-5.6. The vertical separation H should be in excess of 50mm. A plug may be fitted to allow cleaning or inspection.

Figure 3-5.6: Drain piping water traps

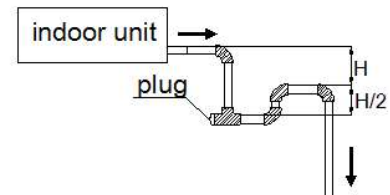

5.3 Selecting Piping Diameters

Select branch drainage piping (the drain piping connection to each unit) diameters according to indoor unit flow volume and select main drainage piping diameters according to the combined flow volume of the upstream indoor units. Use a design assumption of 2 liters of condensate per horsepower per hour. For example, the combined flow volume of three 2HP units and two 1.5HP units would be calculated as follows:

$$\begin{aligned} \text{Combined flow volume} &= 3 \times 2 \text{ L/HP/h} \times 2\text{HP} &= 18 \text{ L/h} \\ &+ 2 \times 2 \text{ L/HP/h} \times 1.5\text{HP} \end{aligned}$$

Tables 3-5.1 and 3-5.2 specify the required piping diameters for horizontal and vertical branch piping and for main piping. Note that main piping should use PVC40 or larger.

Table 3-5.1: Horizontal drain piping diameters

PVC piping	Nominal diameter (mm)	Capacity (L/h)		Remarks
		Slope 1:50	Slope 1:100	
PVC25	25	39	27	Branch piping only
PVC32	32	70	50	
PVC40	40	125	88	Branch or main piping
PVC50	50	247	175	
PVC63	63	473	334	

Table 3-5.2: Vertical drain piping diameters

PVC piping	Nominal diameter (mm)	Capacity (L/h)	Remarks
PVC25	25	220	Branch piping only
PVC32	32	410	
PVC40	40	730	Branch or main piping
PVC50	50	1440	
PVC63	63	2760	
PVC75	75	5710	
PVC90	90	8280	

5.4 Drain Piping for Units with Lift Pumps

Drain piping for units with lift pumps should take account of the following additional considerations:

- A downward sloping section should immediately follow the vertically rising section adjacent to the unit, otherwise a water pump error will occur. Refer to Figure 3-5.7.
- Air vents should not be installed on vertically rising sections of drain piping, otherwise water may be discharged through the air vent or water flow may be impeded.

Figure 3-5.7: Downward sloping section of drain piping

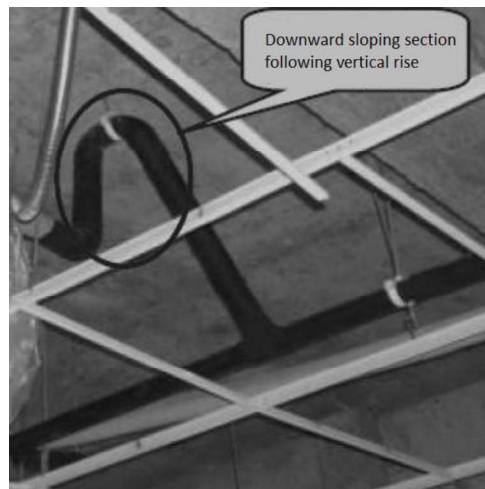

5.5 Drain Piping Installation

Notes for installers



Installation of the drain piping should proceed in the following order:

Indoor unit installation

Drain piping
installation

Water tightness
test

Drain piping insulation

Caution

- Ensure that all joints are firm and once the drain piping is all connected conduct a water tightness test and water flow test.
- Do not connect air conditioner drain piping to waste, rainwater or other drain piping and do not let air conditioner drain piping come into direct contact with the ground.
- For units with drain pumps, test that the drain pump functions properly by adding water to the unit's drainage pan and running the unit. To allow inspection and maintenance, the pipe clamps shipped with units should be used to attach drain piping to indoor units – adhesive should not be used.

5.6 Water tightness Test and Water Flow Test

Once installation of a drainage piping system is complete, water tightness and water flow tests should be performed.

Notes for installers



Water tightness test

- Fill the piping with water and test for leakages over a 24-hour period.

Water flow test (natural drainage test)

- Slowly fill the drainage pan of each indoor unit with at least 600ml of water through the inspection port and check that the water is discharged through the outlet of the drain piping.

Caution

- The drain plug in the drainage pan is for removing accumulated water prior to performing indoor unit maintenance. During normal operation, the drain should be plugged to prevent leakage.

6 Insulation

6.1 Refrigerant Piping Insulation

6.1.1 Purpose

During operation, the temperature of the refrigerant piping varies. Insulation is required to ensure unit performance and compressor lifespan. During cooling, the gas pipe temperature can be very low. Insulation prevents condensation forming on the piping. During heating, the gas pipe temperature can rise to as high as 100°C. Insulation serves as necessary protection from burns.

6.1.2 Selecting insulation materials

Refrigerant piping insulation should be closed-cell foam of B1 fire resistance rating that can withstand a constant temperature of over 120°C and that complies with all applicable legislation.

6.1.3 Thickness of insulation

Carry out heat insulation treatment for the pipes at the gas and liquid sides respectively. Pipes on the liquid and air sides have a low temperature during cooling. Take sufficient insulation measures to prevent condensation. Minimum thicknesses for refrigerant piping insulation are specified in Table 3-6.1.

Table 3-6.1: Refrigerant piping insulation thickness

Pipe outer diameter (mm)	Minimum insulation thickness (mm)
Φ6.35	15
Φ9.53	
Φ12.7	
Φ15.9	20
Φ19.1	
Φ22.2	
Φ25.4	
Φ28.6	

6.1.4 Installation of piping insulation

With the exception of joint insulation, insulation should be applied to piping before fixing the piping in place. Insulation at joints in refrigerant piping should be applied after the gas tightness test has been completed.

Notes for installers



- Installation of insulation should be carried out in a manner suited to the type of insulation material being used.
- Ensure there are no gaps at the joints between sections of insulation.
- Do not apply tape too tightly as doing so may shrink insulation, reducing its insulating properties leading to condensation and loss of efficiency.
- Insulate gas and liquid pipes separately, otherwise heat exchange between the two sides will greatly impact efficiency.
- Do not bind the separately insulated gas and liquid pipes together too tightly as doing so can damage the joints between sections of insulation.

6.1.5 Installation of joint insulation

Insulation at joints in the refrigerant piping should be installed after the gas tightness test has been successfully completed. The procedure at each joint is as follows:

1. Cut a section of insulation 50 to 100mm longer than the gap to be filled. Ensure that the cross-sectional and longitudinal openings are all cut evenly.
2. Embed the section into the gap ensuring that the ends abut tightly to the sections of insulation either side of the gap.
3. Glue the longitudinal cut and the joints with the sections of insulation either side of the gap.
4. Seal the seams with tape.

Figure 3-6.1: Installation of joint insulation (unit: mm)

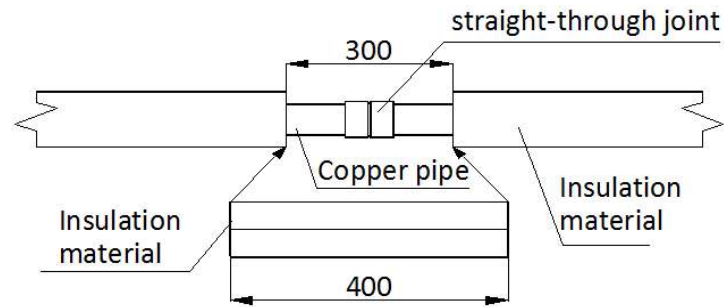

6.2 Drain Piping Insulation

- Use rubber/plastic insulating tube with a B1 fire resistance rating.
- The insulation should typically be in excess of 10mm thick.
- For drain piping installed inside a wall, insulation is not required.
- Use suitable adhesive to seal seams and joints in the insulation and then bind with cloth reinforced tape of width not less than 50mm. Ensure tape is fixed firmly to avoid condensation.
- Ensure the drain piping insulation adjacent to the indoor unit drainage water outlet is fixed to the unit itself using adhesive, to prevent condensation and dripping.

6.3 Ducting Insulation

- Suitable insulation should be added to ducting in according with all applicable legislation.

7 Charging Refrigerant

7.1 Calculating Additional Refrigerant Charge

The additional refrigerant charge required depends on the lengths and diameters of the outdoor and indoor liquid pipes. Table 3-7.1 shows the additional refrigerant charge required per meter of equivalent pipe length for different diameters of pipe. The total additional refrigerant charge is obtained by summing the additional charge requirements for each of the outdoor and indoor liquid pipes, as in the following formula, where L_1 to L_8 represent the equivalent lengths of the pipes of different diameters. Assume 0.5m for the equivalent pipe length of each branch joint.

$$\begin{aligned} \text{Additional refrigerant charge R (kg)} &= L_1 (\Phi 6.35) \times 0.022 \\ &+ L_2 (\Phi 9.53) \times 0.054 \\ &+ L_3 (\Phi 12.7) \times 0.110 \\ &+ L_4 (\Phi 15.9) \times 0.170 \end{aligned}$$

Table 3-7.1: Additional refrigerant charge

Liquid side piping (mm)	Additional refrigerant charge per meter of equivalent length of piping (kg)
Φ6.35	0.022
Φ9.53	0.054
Φ12.7	0.110
Φ15.9	0.170

7.2 Adding Refrigerant

Notes for installers



Caution

- Only charge refrigerant after performing a gas tightness test and vacuum drying.
- Never charge more refrigerant than required as doing so can lead to liquid hammering.
- Only use refrigerant R410A - charging with an unsuitable substance may cause explosions or accidents.
- Use tools and equipment designed for use with R410A to ensure required pressure resistance and to prevent foreign materials from entering the system.
- Refrigerant must be treated in accordance with applicable legislation.
- Always use protective gloves and protect your eyes when charging refrigerant.
- Open refrigerant containers slowly.

Procedure

The procedure for adding refrigerant is as follows:

Step 1

- Calculate additional refrigerant charge R (kg) (see Part 3, 7.1 “Calculating Additional Refrigerant Charge”)

Step 2

- Place a tank of R410A refrigerant on a weighing scale. Turn the tank upside down to ensure refrigerant is charged in a liquid state. (R410A is a blend of two different chemicals compounds. Charging gaseous R410A into the system could mean that the refrigerant charged is not of the correct composition).
- After vacuum drying (see Part 3, 4.9 “Vacuum Drying”), the blue and red pressure gauge hoses should still be connected to the pressure gauge and to the master unit stop valves.
- Connect the yellow hose from the pressure gauge to the R410A refrigerant tank.

Step 3

- Open the valve where the yellow hose meets the pressure gauge, and open the refrigerant tank slightly to let the refrigerant eliminate the air. Caution: open the tank slowly to avoid freezing your hand.
- Set the weighing scale to zero.

Box continued on next page ...

Step 4

- Open the three valves on the pressure gauge to begin charging refrigerant.
- When the amount charged reaches R (kg), close the three valves. If the amount charged has not reached R (kg) but no additional refrigerant can be charged, close the three valves on the pressure gauge, run the outdoor unit in cooling mode, and then open the yellow and blue valves. Continue charging until the full R (kg) of refrigerant has been charged, then close the yellow and blue valves. Note: Before running the system, be sure to complete all the pre-commissioning checks as listed in Part 3, 10.2 “Pre-commissioning Checks” and be sure to open all stop valves as running the system with the stop valves closed would damage the compressor.

Figure 3-7.1: Charging refrigerant

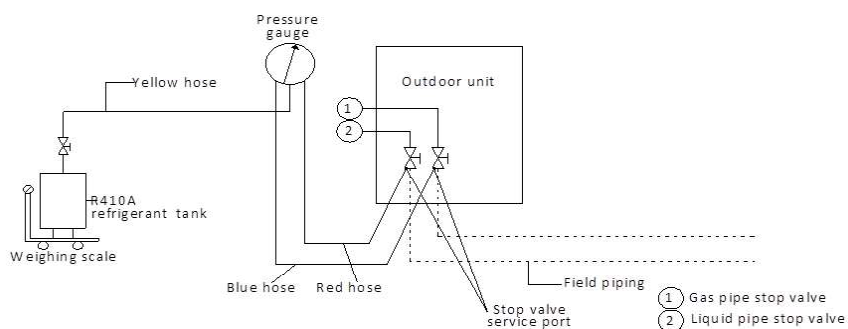

Pressure gauge

8 Electrical Wiring

8.1 General

Notes for installers



Caution

- All installation and wiring must be carried out by competent and suitably qualified, certified and accredited professionals and in accordance with all applicable legislation.
- Electrical systems should be grounded in accordance with all applicable legislation.
- Overcurrent circuit breakers and residual-current circuit breakers (ground fault circuit interrupters) should be used in accordance with all applicable legislation.
- Wiring patterns shown in this data book are general connection guides only and are not intended for, or to include all details for, any specific installation.
- The refrigerant piping, power wiring and communication wiring are typically run in parallel. However the communication wiring should not be bound together with the refrigerant piping or power wiring. To prevent signal interference, the power wiring and communication wiring should not be run in the same conduit. If the power supply is less than 10A, a separation of at least 300mm between power wiring and communication wiring conduits should be maintained; if the power supply is in the range 10A to 50A then a separation of at least 500mm should be maintained.

8.2 Power Supply Wiring

Power supply wiring design and installation should adhere to the following requirements:

- Separate power supplies should be provided for the indoor units and outdoor unit.
- Where five or more outdoor units are installed, additional residual current protection (leakage protection) should be installed.
- All the indoor units in a system (i.e. all the indoor units connected to the same outdoor unit) should be tied into the same power circuit with the same power supply, overcurrent and residual current protection (leakage protection) and manual switch, as shown in Figure 3-8.1. Do not install separate protectors or manual switches for each indoor unit. Powering on and shutting down all indoor units in a system should be done simultaneously. The reason for this is that if an indoor unit that is running were to suddenly power off whilst the other indoor units continued running, the evaporator of the powered-off unit would freeze since refrigerant would continue flowing to that unit (its expansion valve would still be open) but its fan would have stopped. The indoor units that remain running would not get sufficient refrigerant so their performance would suffer. Additionally, liquid refrigerant returning directly to the compressor from the powered-off unit would cause liquid hammering, potentially damaging the compressor.
- For outdoor unit power wire sizing and circuit breaker sizing, refer to Table 2-6.1 in Part 2, 6 “Electrical Characteristics”.

Figure 3-8.1: Indoor unit power supply wiring

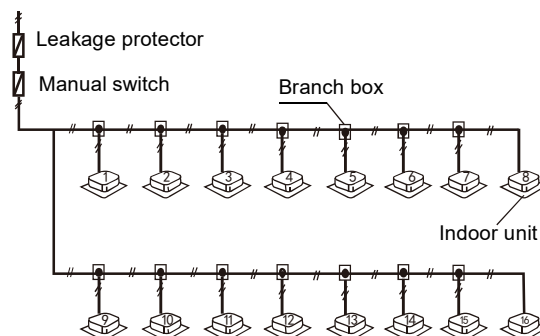

Notes for installers



The power supply should be connected to the outdoor unit power supply terminals as shown in Figure 3-8.2.

Figure 3-8.2: Outdoor unit 1-phase power supply terminals

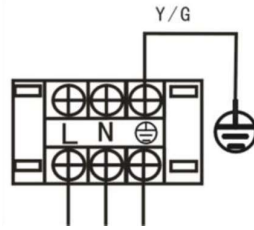

8.3 Communication Wiring

Communication wiring design and installation should adhere to the following requirements:

- 0.75mm² three-core shielded cable should be used for communication wiring. Using other types of cable can lead to interference and malfunction.
- **Indoor communication wiring:**
 - The P Q E communication wires should be connected one unit after another in a daisy chain from the outdoor unit to the final indoor unit. At the final indoor unit, a 120Ω resistor should be connected between the P and Q terminals. After the final indoor unit, the communication wiring should NOT be continued back to the outdoor unit – that is, do not attempt to form a closed loop.
 - The P and Q communication wires should NOT be grounded.
 - The shielding nets of the communication wires should be connected together and grounded. Grounding can be achieved by connecting to the metal casing adjacent to the P Q E terminals of the outdoor unit electrical control box.

Notes for installers



The communication wires should be connected to the outdoor unit terminals indicated in Figure 3-8.3 and Table 3-8.2.

Caution

- Communication wiring has polarity. Care should be taken to connect the poles correctly.

Figure 3-8.3: Outdoor unit communication terminals

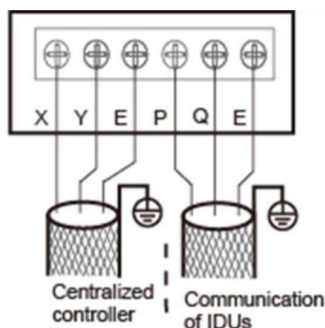
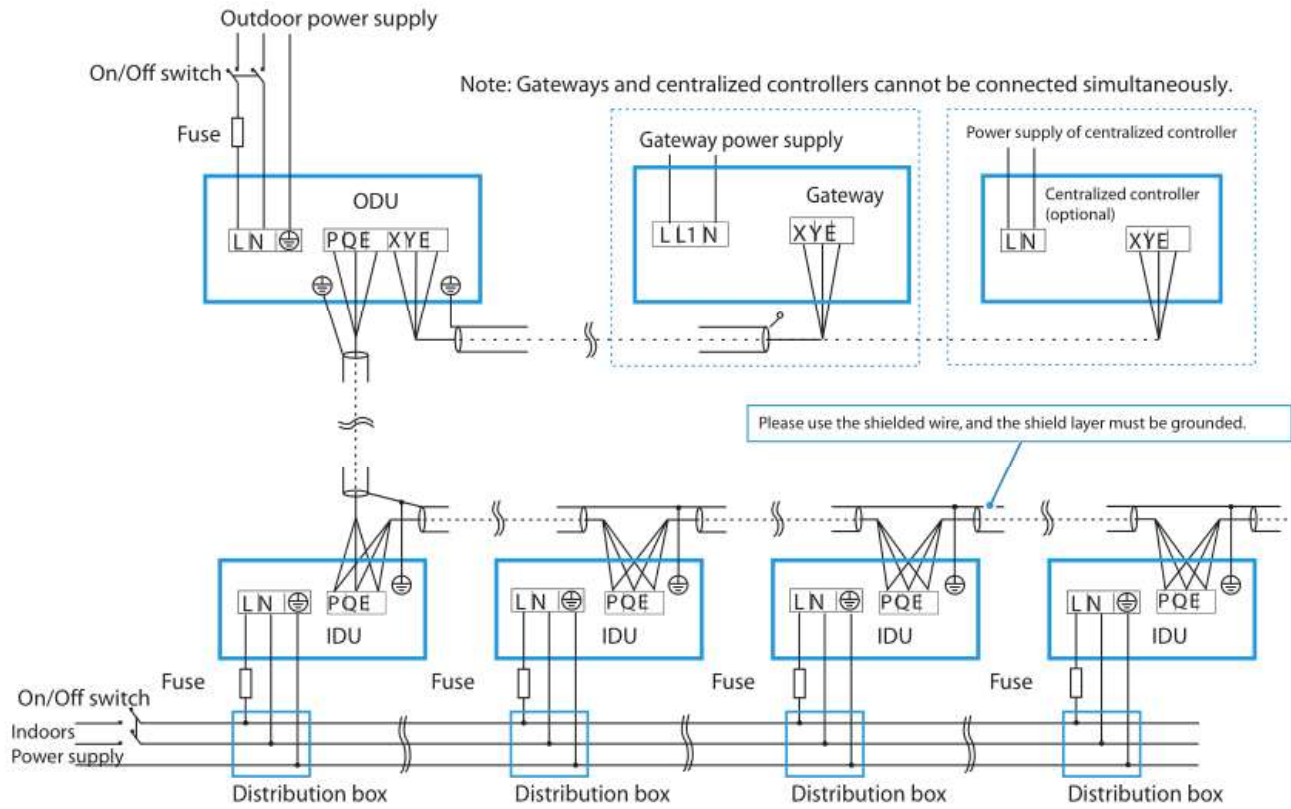

Table 3-8.2: Communication connections

Terminals	Connection
X Y E	Connect to centralized controller or gateway
P Q E	Connect between indoor units and outdoor unit

Figure 3-8.4: System power wiring example



8.4 Wiring example

Figure 3-8.4: System communication wiring example

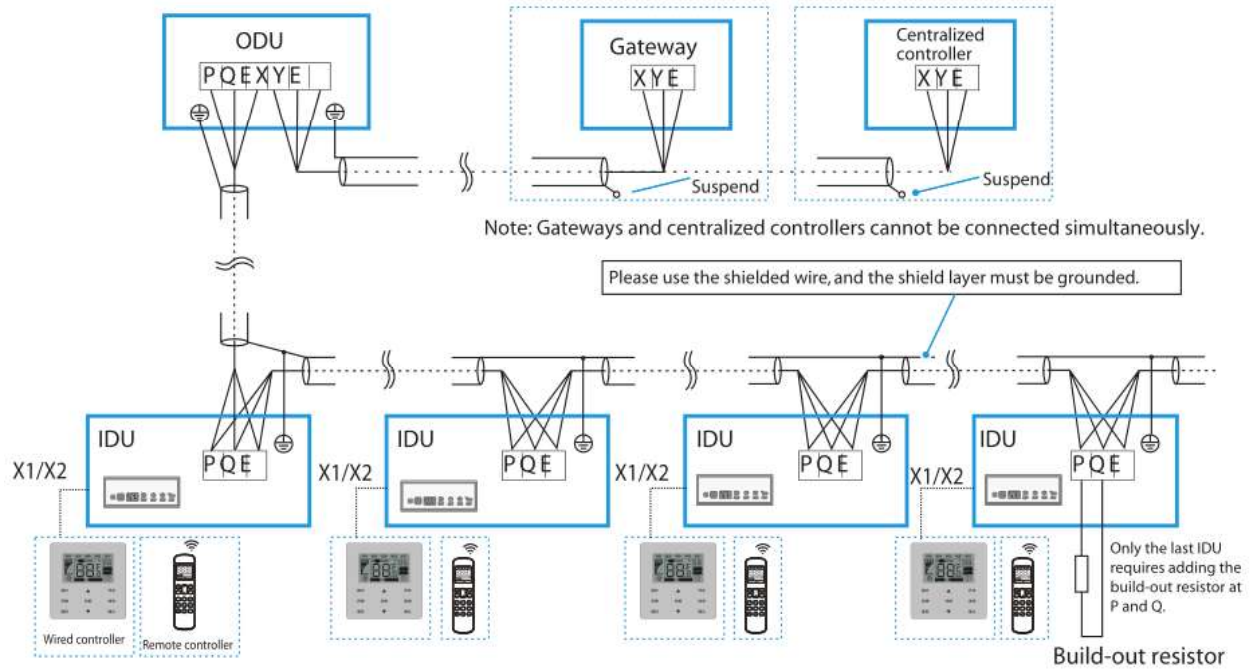

Note: The wired controller and centralized controller in the dashed box are optional accessories. If necessary, please contact the local distributor for purchase.

9 Installation in Areas of High Salinity

9.1 Caution

Do not install outdoor units where they could be directly exposed to sea air. Corrosion, particularly on the condenser and evaporator fins, could cause product malfunction or inefficient performance.

Outdoor units installed in seaside locations should be placed such as to avoid direct exposure to the sea air and additional anticorrosion treatment options should be selected, otherwise the service life of the outdoor units will be seriously affected.

Air conditioning installed in seaside locations should be run regularly as the running of the outdoor unit fans helps prevent build-up of salt on the outdoor unit heat exchangers.

9.2 Placement and Installation

Outdoor units should be installed 300m or more from the sea. If possible, well-ventilated indoor locations should be chosen. If it is necessary to install outdoor units outside, direct exposure to the sea air should be avoided. A canopy should be added to shield the units from sea air and rain.

Ensure that base structures drain well so that outdoor unit footings do not become waterlogged. Check that outdoor unit casing drainage holes are not blocked.

9.3 Inspection and maintenance

In addition to standard outdoor unit servicing and maintenance, the following additional inspections and maintenance should be undertaken for outdoor units installed in seaside locations:

- A comprehensive post-installation inspection should check for any scratches or other damage to painted surfaces and any damaged areas should be repainted/repaired immediately.
- The units should be regularly cleaned using (non-salty) water to remove any salt that has accumulated. Areas cleaned should include the condenser, the refrigerant piping system, the outside surface of the unit casing and the outside surface of the electric control box.
- Regular inspections should check for corrosion and if necessary corroded components should be replaced and/or anti-corrosion treatments should be added.

10 Commissioning

10.1 Multi-system Projects

For projects with multiple refrigerant systems, each independent refrigeration system (i.e. each system of one outdoor unit and its connected indoor units) should be given a test run independently, before the multiple systems that make up a project are run simultaneously.

10.2 Pre-commissioning Checks

Before turning on the power to the indoor and outdoor units, ensure the following:

1. All indoor and outdoor refrigeration piping and communication wiring has been connected to the correct refrigeration system and the system to which each indoor and outdoor unit belongs is clearly marked on each unit or recorded in some other suitable place.
2. Pipe flushing, gas tightness testing and vacuum drying have been satisfactorily completed as per instructions.
3. All condensate drain piping is complete and a water tightness test has been satisfactorily completed.
4. All power and communication wiring is connected to the correct terminals on units and controllers.
5. No wiring has been connected in a short-circuit.
6. The power supplies to indoor and outdoor units have been checked and the power supply voltages are within $\pm 10\%$ of the rated voltages for each product.
7. All control wiring is 0.75mm² three-core shielded cable and the shielding has been grounded.
8. Indoor and outdoor unit field settings have been set as required.
9. The additional refrigerant charge has been added as per Part 3, 7 “Charging Refrigerant”. Note: In some circumstances it may be necessary to run the system in cooling mode during the refrigerant charging procedure. In such circumstances, points 1 to 8 above should be checked before running the system for the purpose of charging refrigerant and the outdoor unit liquid and gas stop valves should be opened.

During commissioning, it is important that you:

- Keep a supply of R410A refrigerant at hand.
- Keep the system layout, system piping and control wiring diagrams at hand.

10.3 Commissioning Trial Runs

10.3.1 Commissioning test run of single refrigerant system

Once all the pre-commissioning checks in Part 3, 10.2 “Pre-commissioning Checks” have been completed, a test run should be performed as described below and an ULTIMA Series System Commissioning Report (see Part 3, 11 “Appendix to Part 3 – System Commissioning Report”) should be completed as a record of the operating status of the system during commissioning.

Note: When running the system for commissioning test runs, if the combination ratio is 100% or less, run all the indoor units and if the combination ratio is more than 100%, run indoor units with total capacity equal to the capacity of the outdoor unit.

The test run procedure is as follows:

1. Open the outdoor unit liquid and gas stop valves.
2. Turn on the power to the outdoor unit.
3. If manual addressing is being used, set the addresses of each indoor unit.
4. Leave the power on for a minimum of 12 hours prior to running the system to ensure that the crankcase heaters have heated the compressor oil sufficiently.
5. Run the system:
 - a) Run the system in cooling mode with the following settings: temperature 17°C; fan speed high.
 - b) After one hour, complete Sheet A of the system commissioning report then check the system parameters using

the CHECK button on the outdoor unit's main PCB and complete the cooling mode columns of one Sheet D and one Sheet E of the system commissioning report for the outdoor unit.

- c) Run the system in heating mode with the following settings: temperature 30°C; fan speed high.
 - d) After one hour, complete Sheet B of the system commissioning report then check the system parameters using the CHECK button on the outdoor unit's main PCB and complete the heating mode columns of one Sheet D and one Sheet E of the system commissioning report for the outdoor unit.
6. Finally, complete Sheet C of the system commissioning report.

10.3.2 Commissioning test run of multiple refrigerant systems

Once the commissioning test run of each refrigerant system has been satisfactorily completed as per Part 3, 10.3.1 "Commissioning test run of single refrigerant system", run the multiple systems that make up a project simultaneously and check for any abnormalities.

11 Appendix to Part 3 – System Commissioning Report

A total of up to 3 report sheets should be completed for each system:

- One Sheet A, one Sheet B per system.
- One Sheet C per outdoor unit.

System Commissioning Report – Sheet A

SYSTEM INFORMATION			
Project name and location		Customer company	
System name		Installation company	
Commissioning date		Agent company	
Outdoor ambient temp.		Commissioning engineer	
Outdoor unit information	Model	Serial no.	Power supply (V)

OUTDOOR UNIT								
COOLING MODE PARAMETER RECORD (After running in cooling mode for one hour)	Compressor suction pipe temperature				Current (A)			
	System pressure at check port				Within normal range?			
	INDOOR UNITS							
	(Sample of over 20% of the indoor units including the unit farthest from the outdoor unit)							
	Room no.	Model	Address	Set temp. (°C)	Inlet temp. (°C)	Outlet temp. (°C)	Drainage OK?	Abnormal noise/vibration?

System Commissioning Report – Sheet B

Project name and location	System name
---------------------------	-------------

RECORD OF ISSUES SEEN DURING COMMISSIONING				
No.	Description of observed issue	Suspected cause	Troubleshooting undertaken	Serial no. of relevant unit
1				
2				
3				

OUTDOOR UNIT FINAL CHECKLIST	
SW2 system check performed?	
Any abnormal noise?	
Any abnormal vibration?	
Fan rotation normal?	

	Commissioning engineer	Dealer	OMEGA representative
Name:			
Signature:			
Date:			

System Commissioning Report – Sheet C

Project name and location		System name		
DSP1 content	Parameters displayed on DSP2	Remarks	Observed values	
			Cooling mode	Heating mode
0.--	Operating frequency	Actual value = value displayed		
1.--	Operating mode	0-Standby;2-Cooling;4-Forced cooling		
2.--	Operating fan speed level	The fan speed index is related to the fan speed in rpm.		
3.--	Total capacity requirement of indoor units			
4.--	Total capacity requirement for the modified ODU			
5.--	T3 Condenser temperature(°C)	Actual value = value displayed		
6.--	T4 Outdoor ambient temperature(°C)	Actual value = value displayed		
7.--	T5 discharge temperature(°C)	Actual value = value displayed		
8.--	TF invert module Temperature(°C)	Actual value = value displayed		
9.--	TL refrigerant cooling tube temperature (°C)	Actual value = value displayed		
10.--	EXVA position	Actual value = value displayed× 8		
11.--	Actual current (A)	Actual value = value displayed		
12.--	Inverter compressor current (A)	Actual value = value displayed		
13.--	Actual voltage (V)	Actual value = value displayed		
14.--	DC bus voltage (V)	Actual value = value displayed		
15.--	Indoor heat exchanger pipe (T2/T2B) average temperature (°C)	Actual value = value displayed		
16.--	Total number of IDUs	Actual value = value displayed		
17.--	Number of Operating IDUs			
18.--	Model			
19.--	System address	ODU address in the centralized control system		
20.--	Priority mode	Cooling only		
21.--	Version of the program			
22.--	Most recent error or protection code	“nn” is displayed if no error or protection events have occurred since start-up		
23.--	Display “--”			



OMEGA
ENVIRONMENTAL
TECHNOLOGIES LLC.

17702 Mitchell North, #101
Irvine, CA. 92614 .USA
Tel: 714 795 2830
Fax: 714 966 1646
info@omegainverter.com
www.omegainverter.com

OTECTM
AIR CONDITIONING

Showroom & Technology Center
11380 Interchange Circle North
Miramar, FL 33025 .USA
Tel: 305 901 1270
Fax: 954 212 8280
info@otecomega.com
wwwotecomega.com

BCSFCM-TM1D0622