



IEWV/ICHV Series High Wall Inverter Installation Manual

ENGLISH

- ✓ Read this Manual before the operation and keep it for reference.
- ✓ Read all safety precautions on the manual, improper use can cause serious injury.

Specification and performance data listed herein are subject to change without notice

www.omegainverter.com

CONTENT

1. Installation Manual	1
1.1 Notices for Installation.....	1
1.2 Installation Dimension Diagram.....	2
1.3 Installation Indoor Unit.....	4
1.4 Installation Outdoor Unit.....	8
1.5 Check after installation	12
1.6 Test operation	12
1.7 Configuration of connection pipe	13
1.8 Pipe expanding method.....	14
2. Function and Control	15
2.1 Remote Controller Operations	15

1. Installation Manual

1.1 Notices for Installation



Caution

- 1.The unit should be installed only by authorized service center according to local or government regulations and in compliance with this manual.
- 2.Before installing, please contact with local authorized maintenance center. If the unit is not installed by the authorized service center, the malfunction may not be solved due to inconvenient contact between the user and the service personnel.
- 3.When removing the unit to the other place, please firstly contact with the local authorized service center.
- 4.Warning: Before obtaining access to terminals, all supply circuits must be disconnected.
- 5.For appliances with type Y attachment, the instructions shall contain the substance of the following. If the supply cord is damaged, it must be replaced by the manufacturer, its service agent or similarly qualified persons in order to avoid a hazard.
- 6.The appliance must be positioned so that the plug is accessible.
- 7.The temperature of refrigerant line will be high; please keep the interconnection cable away from the copper tube.
- 8.The instructions shall state the substance of the following:This appliance is not intended for use by persons(including children)with reduced physical, sensory or mental capabilities, or lack of experience and knowledge, unless they have been given supervision or instruction concerning use of the appliance by a person responsible for their safety. Children should be supervised to ensure that they do not play with the appliance.

1.1.1 Installation Site Instructions

Installing the unit in the following places may cause malfunction. If it is unavoidable, please consult the local dealer:

- 1.The place with strong heat sources, vapors, flammable or explosive gas, or volatile objects spread in the air.
- 2.The place with high-frequency devices (such as welding machine, medical equipment).
- 3.The place near coast area.
- 4.The place with oil or fumes in the air.
- 5.The place with sulfureted gas.
- 6.Other places with special circumstances.
- 7.The appliance shall not be installed in the laundry.

1.1.2 Installation Site of Indoor Unit

1. There should be no obstruction near air inlet and air outlet.
2. Select a location where the condensation water can be dispersed easily and won't affect other people.
3. Select a location which is convenient to connect the outdoor unit and near the power socket.
4. Select a location which is out of reach for children.
5. The location should be able to withstand the weight of indoor unit and won't increase noise and vibration.
6. The appliance must be installed 2.5m above floor.
7. Don't install the indoor unit right above the electric appliance.
8. Please try your best to keep way from fluorescent lamp.

1.1.3 Installation Site of Outdoor Unit

- 1.Select a location where the noise and out flow air emitted by the outdoor unit will not affect neighborhood.
- 2.The location should be well ventilated and dry, in which the outdoor unit won't be exposed directly to sunlight or strong wind.
- 3.The location should be able to withstand the weight of outdoor unit.
- 4.Make sure that the installation follows the requirement of installation dimension diagram.
- 5.Select a location which is out of reach for children and far away from animals or plants.If it is unavoidable, please add the fence for safety purpose.

1.1.4 Safety Precautions for Electric Appliances

1. A dedicated power supply circuit should be used in accordance with local electrical safety regulations.
2. Don't drag the power cord with excessive force.
3. The unit should be reliably earthed and connected to an exclusive earth device by the professionals.
4. The air switch must have the functions of magnetic tripping and heat tripping to prevent short circuit and overload.
5. The minimum distance between the unit and combustive surface is 1.5m.
6. The appliance shall be installed in accordance with national wiring regulations.
7. An all-pole disconnection switch with a contact separation of at least 3mm in all poles should be connected in fixed wiring.

Note:

- **Make sure the live wire, neutral wire and earth wire in the family power socket are properly connected. There should be reliable circuit in the diagram.**
- **Inadequate or incorrect electrical connections may cause electric shock or fire.**

1.1.5 Earthing Requirements

1. Air conditioner is type I electric appliance. Please ensure that the unit is reliably earthed.
2. The yellow-green wire in air conditioner is the earthing wire which can not be used for other purposes. Improper earthing may cause electric shock.
3. The earth resistance should accord to the national criterion.
4. The power must have reliable earthing terminal. Please do not connect the earthing wire with the following:
 - Water pipe
 - Gas pipe
 - Contamination pipe
 - Other place that professional personnel consider is unreliable
5. The model and rated values of fuses should accord with the silk print on fuse cover or related PCB.

1.2 Installation Dimension Diagram

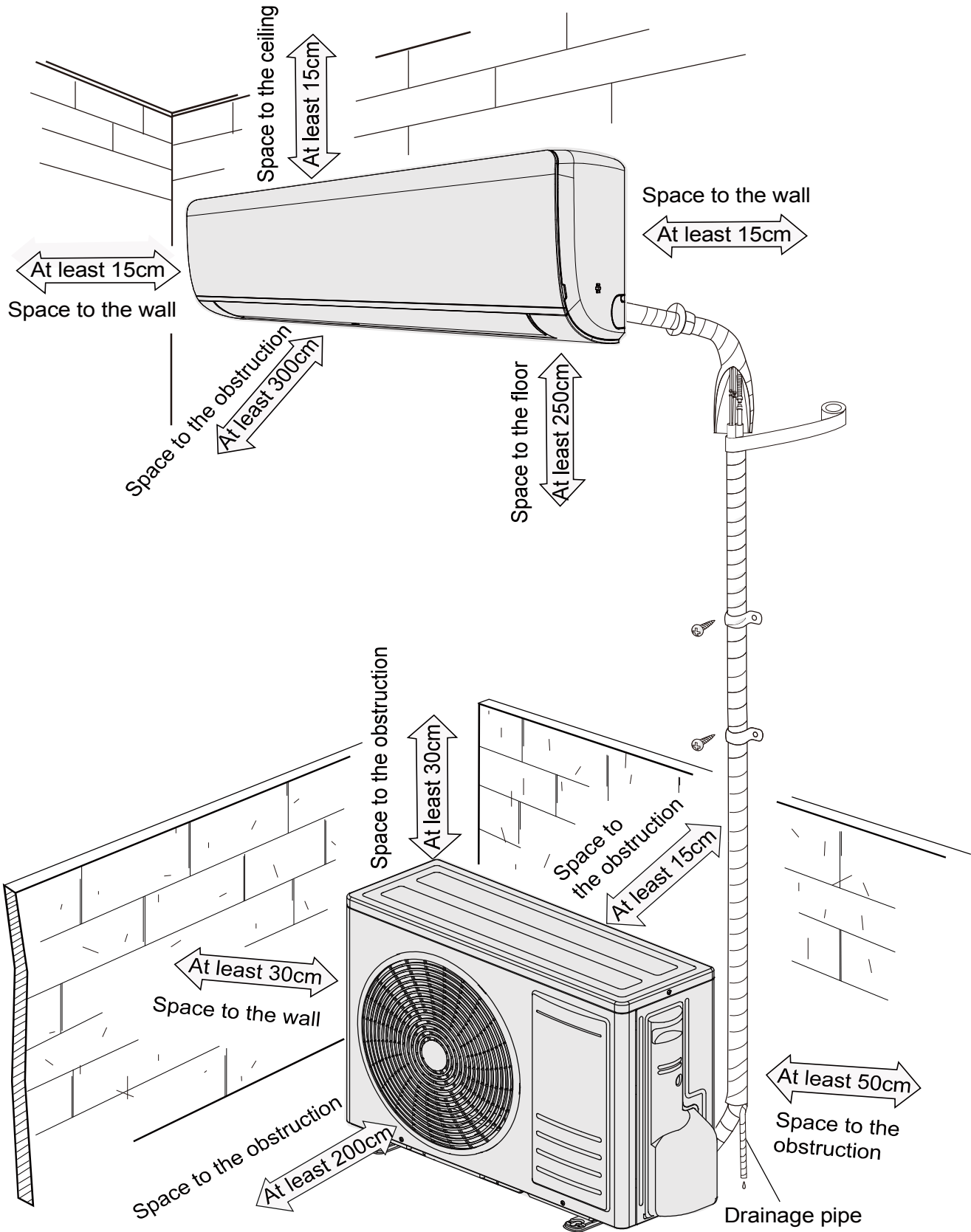

1.3 Installation Indoor Unit

Step 1: Choosing installation location

Recommend the installation location to the client and then confirm it with the client.

Step 2: Install wall-mounting frame

1. Hang the wall-mounting frame on the wall; adjust it in horizontal position with the level meter and then point out the screw fixing holes on the wall .
2. Drill the screw fixing holes on the wall with impact drill (the specification of drill head should be the same as the plastic expansion particle) and then fill the plastic expansion particles in the holes.
3. Fix the wall-mounting frame on the wall with tapping screws (ST4.2X25TA) and then check if the frame is firmly installed by pulling the frame. If the plastic expansion particle is loose, please drill another fixing hole nearby.

Step 3: Open piping hole

1. Choose the position of piping hole according to the direction of outlet pipe. The position of piping hole should be a little lower than the wall-mounted frame, shown as below.

Dimension: 721x274x195 or 743x278x194

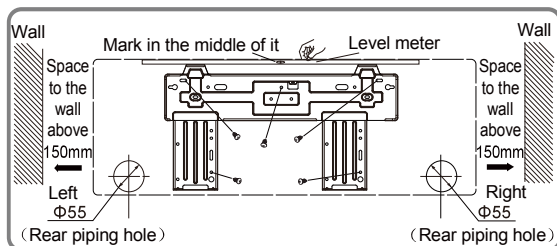

Dimension: 792x279x195 or 821x283x200

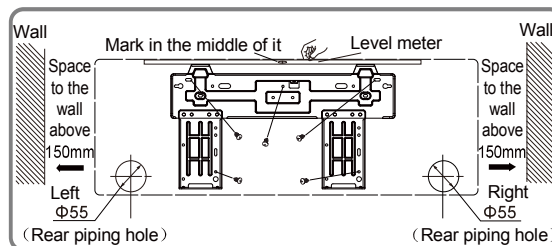

Dimension: 850x291x203 or 884x298x205

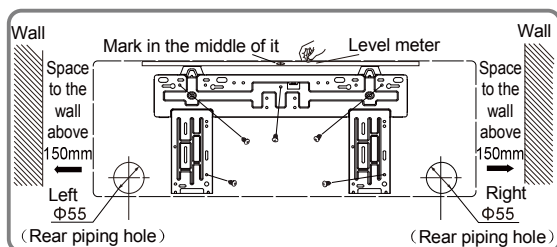

Dimension: 972x302x224 or 1003x310x222

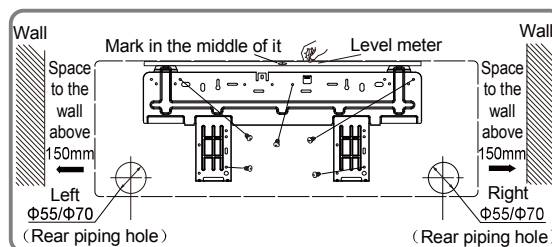

Dimension: 1081x327x248 or 1109x331x250

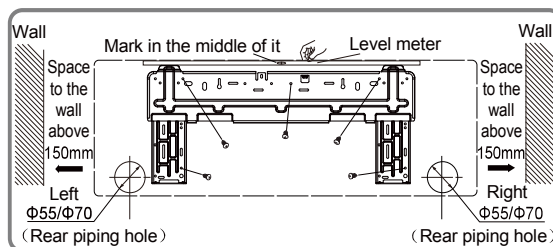

- Open a piping hole with the diameter of $\Phi 55/\Phi 70$ on the selected outlet pipe position. In order to drain smoothly, slant the piping hole on the wall slightly downward to the outdoor side with the gradient of 5-10°.

Note:

- Pay attention to dust prevention and take relevant safety measures when opening the hole.
- The plastic expansion particles are not provided and should be bought locally.

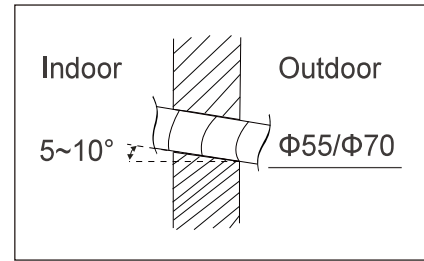

Step 4: Outlet pipe

- The pipe can be led out in the direction of right, rear right or left.

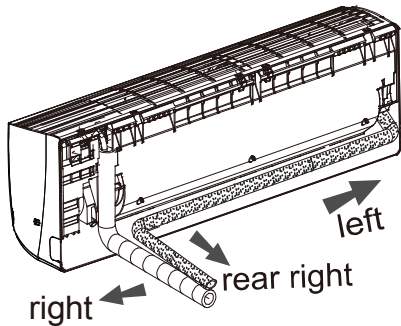

- When select leading out the pipe from left or right, please cut off the corresponding hole on the bottom case.

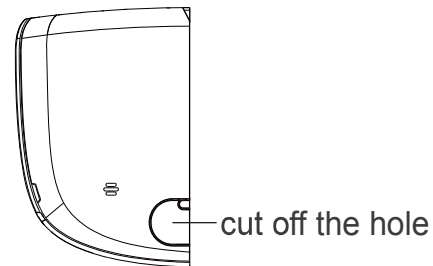

Step 5: Connect the pipe of indoor unit

- Aim the pipe joint at the corresponding bellmouth.
- Pretightening the union nut with hand.
- Adjust the torque force by referring to the following sheet. Place the open-end wrench on the pipe joint and place the torque wrench on the union nut. Tighten the union nut with torque wrench.

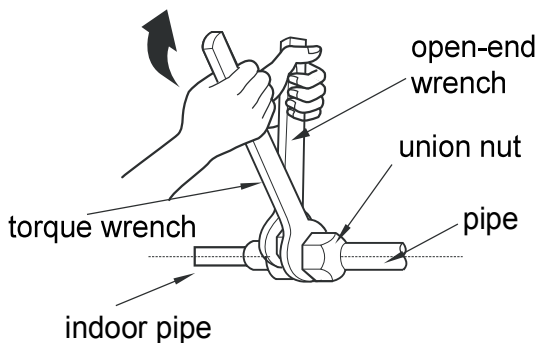
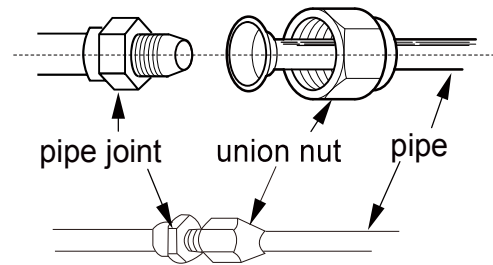

Hex nut diameter	Tightening torque (N·m)
$\Phi 6$	15~20
$\Phi 9.52$	30~40
$\Phi 12$	45~55
$\Phi 16$	60~65
$\Phi 19$	70~75

- Wrap the indoor pipe and joint of connection pipe with insulating pipe, and then wrap it with tape.

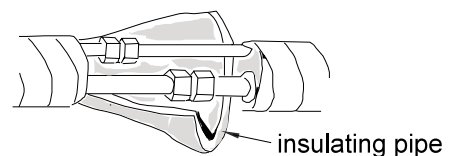

Step 6: Install drain hose

1. Connect the drain hose to the outlet pipe of indoor unit.
2. Bind the joint with tape.

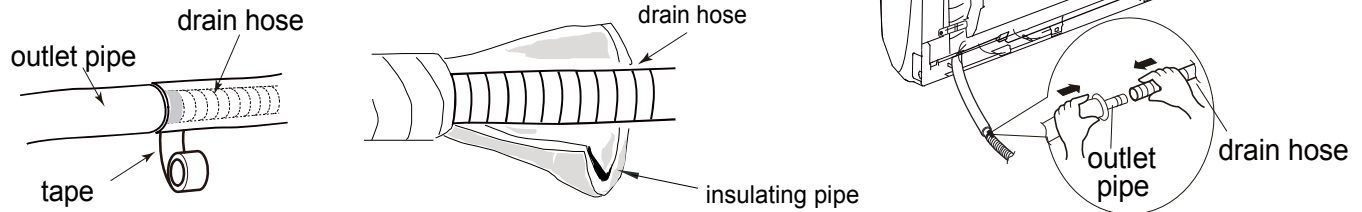

- Add insulating pipe in the indoor drain hose in order to prevent condensation.
- The plastic expansion particles are not provided.

Step 7: Connect wire of indoor unit

1. Open the panel, remove the screw on the wiring cover and then take down the cover.

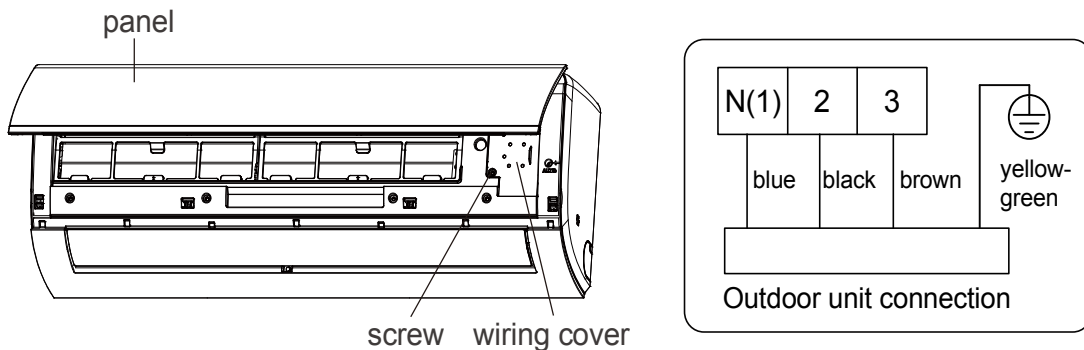

2. Make the power connection wire go through the cable-cross hole at the back of indoor unit and then pull it out from the front side.
3. Remove the wire clip, connect the power connection wire to the wiring terminal according to the color; tighten the screw and then fix the power connection wire with wire clip.
4. Put wiring cover back and then tighten the screw.
5. Close the panel.

Note:

- All wires of indoor unit and outdoor unit should be connected by a professional.
- If the length of power connection wire is insufficient, please contact the supplier for a new one. Avoid extending the wire by yourself.
- For the air conditioner with plug, the plug should be reachable after finishing installation.
- For the air conditioner without plug, an air switch must be installed in the line. The air switch should be all-pole parting and the contact parting distance should be more than 3mm.

Step 8: Bind up pipe

1. Bind up the connection pipe, power cord and drain hose with the band.
2. Reserve a certain length of drain hose and power cord for installation when binding them. When binding to a certain degree, separate the indoor power and then separate the drain hose.

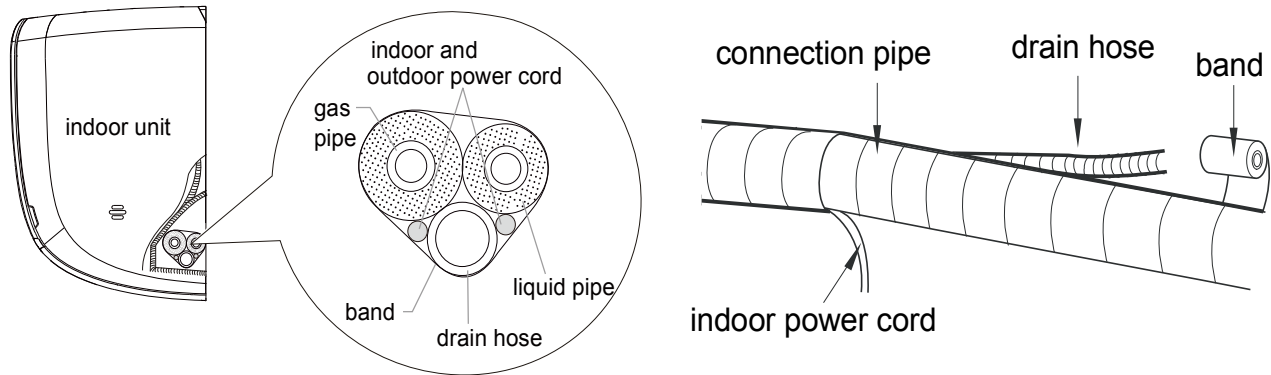

3. Bind them evenly.
4. The liquid pipe and gas pipe should be bound separately at the end.

Note:

- The power cord and control wire can't be crossed or winding.
- The drain hose should be bound at the bottom.

Step 9: Hang the indoor unit

1. Put the bound pipes in the wall pipe and then make them pass through the wall hole.
2. Hang the indoor unit on the wall-mounting frame.
3. Stuff the gap between pipes and wall hole with sealing gum.
4. Fix the wall pipe.
5. Check if the indoor unit is installed firmly and closed to the wall.

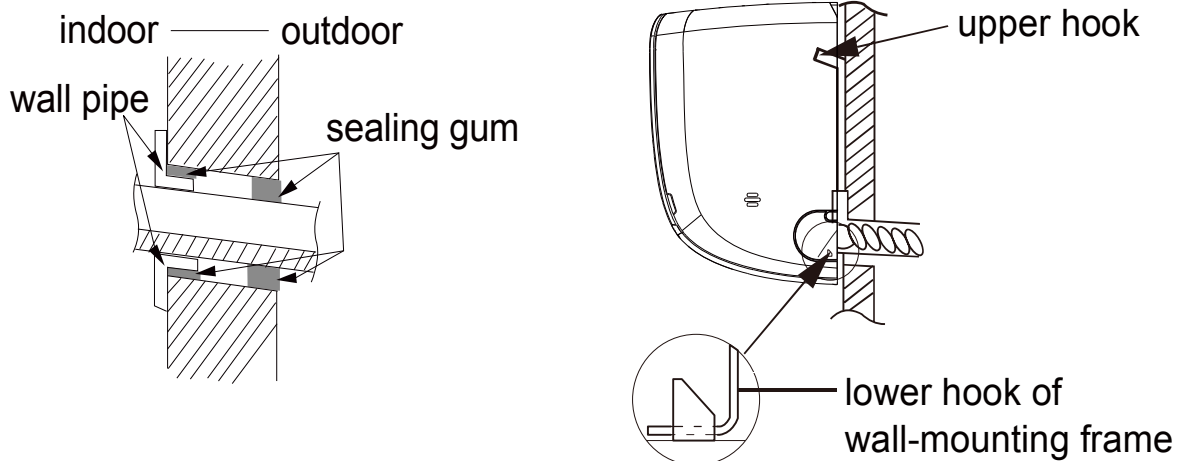

- Do not bend the drain hose too excessively in order to prevent blocking.

1.4 Installation Outdoor Unit

Step 1: Fix the support of outdoor

Select it according to the actual installation situation

1. Select installation location according to the house structure.
2. Fix the support of outdoor unit on the selected location with expansion screws.

Note:

- Take sufficient protective measures when installing the outdoor unit.
- Make sure the support can withstand at least four times of the unit weight.
- The outdoor unit should be installed at least 3cm above the the floor in order to install drainjoint.
- For the unit with cooling capacity of 2300W~5000W, 6 expansion screws are needed; for the unit with cooling capacity of 6000W~8000W, 8 expansion screws are needed; for the unit with cooling capacity of 10000W ~16000W, 10 expansion screws are needed.

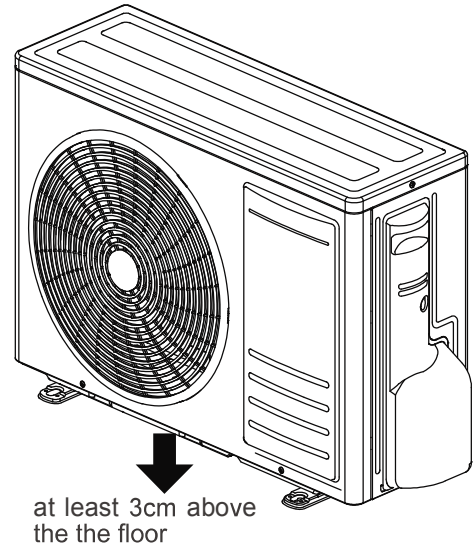

Step 2: Install drain joint (Only for cooling and heating unit)

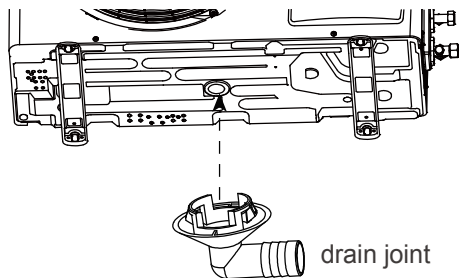

1. Connect the outdoor drain joint into the hole on the chassis, as shown in the picture below.
2. Connect the drain hose into the drain vent.

Step 3: Fix outdoor unit

1. Place the outdoor unit on the support.
2. Fix the foot holes of outdoor unit with bolts.

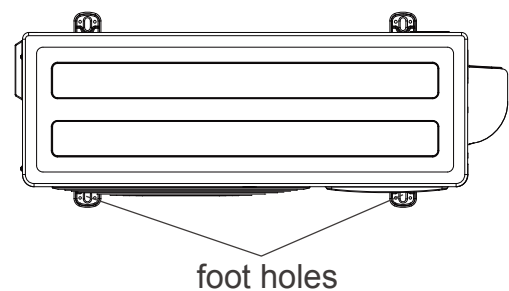

Step 4: Connect indoor and outdoor pipe

1. Remove the screw on the right handle of outdoor unit and then remove the handle.

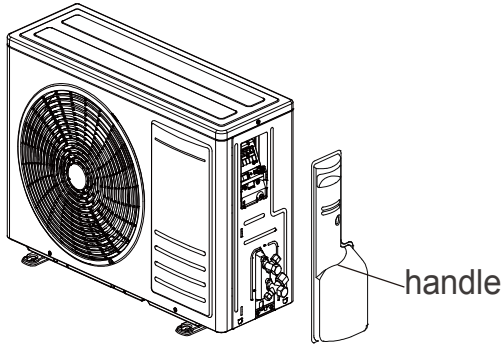

2. Remove the screw cap of valve and aim the pipe joint at the bellmouth of pipe.

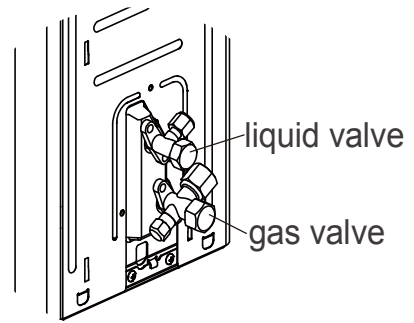

3. Pretightening the union nut with hand.

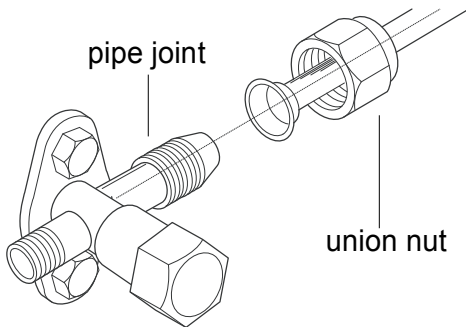

4. Tighten the union nut with torque wrench by referring to the sheet below.

Hex nut diameter	Tightening torque (N·m)
Φ 6	15~20
Φ 9.52	30~40
Φ 12	45~55
Φ 16	60~65
Φ 19	70~75

Step 5: Connect indoor and outdoor pipe

1. Remove the wire clip; connect the power connection wire and signal control wire (only for cooling and heating unit) to the wiring terminal according to the color, fix them with screws.
2. Fix the power connection wire and signal control wire with wire clip (only for cooling and heating unit).

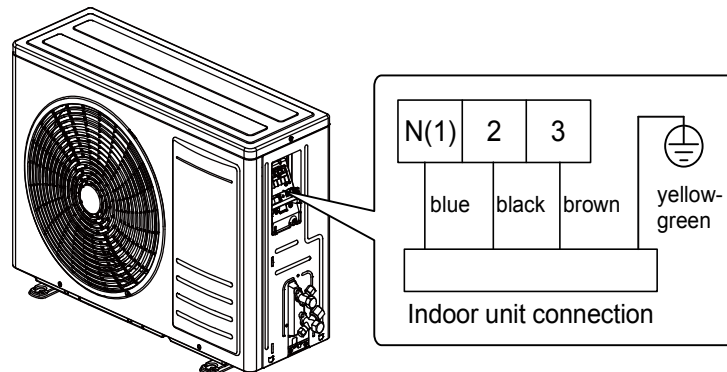

Note:

- After tighten the screw, pull the power cord slightly to check if it is firm.
- Never cut the power connection wire to prolong or shorten the distance.

Step 6: Neaten the pipes

1. The pipes should be placed along the wall, bent reasonably and hidden possibly. Min.semidiometer of bending the pipe is 10cm.
2. If the outdoor unit is higher than the wall hole, you must set a U-shaped curve in the pipe before pipe goes into the room, in order to prevent rain from getting into the room.

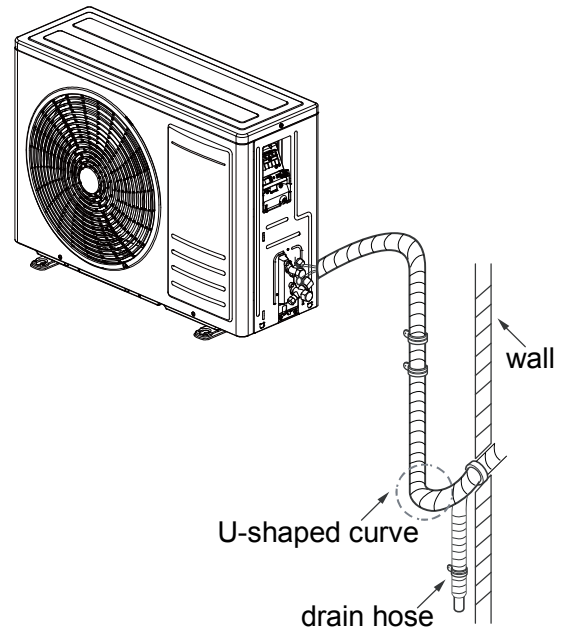

Note:

- The through-wall height of drain hose shouldn't be higher than the outlet pipe hole of indoor unit.
- The water outlet can't be placed in water in order to drain smoothly.

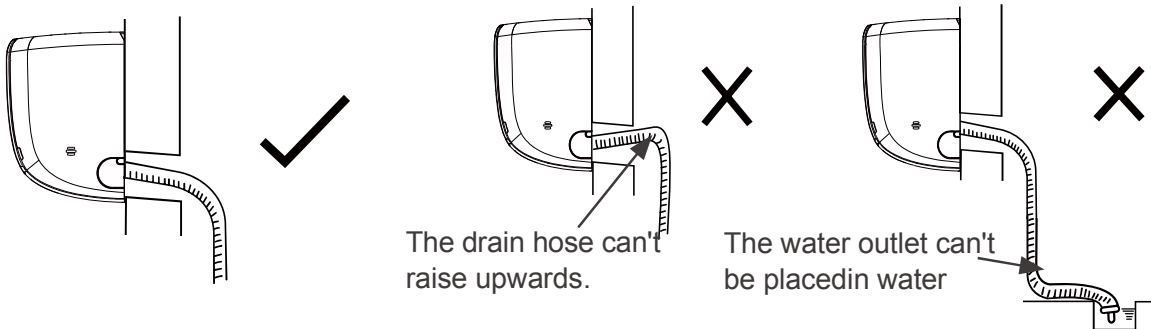

Slant the drain hose slightly downwards. The drain hose can't be curved, raised and fluctuant, etc.

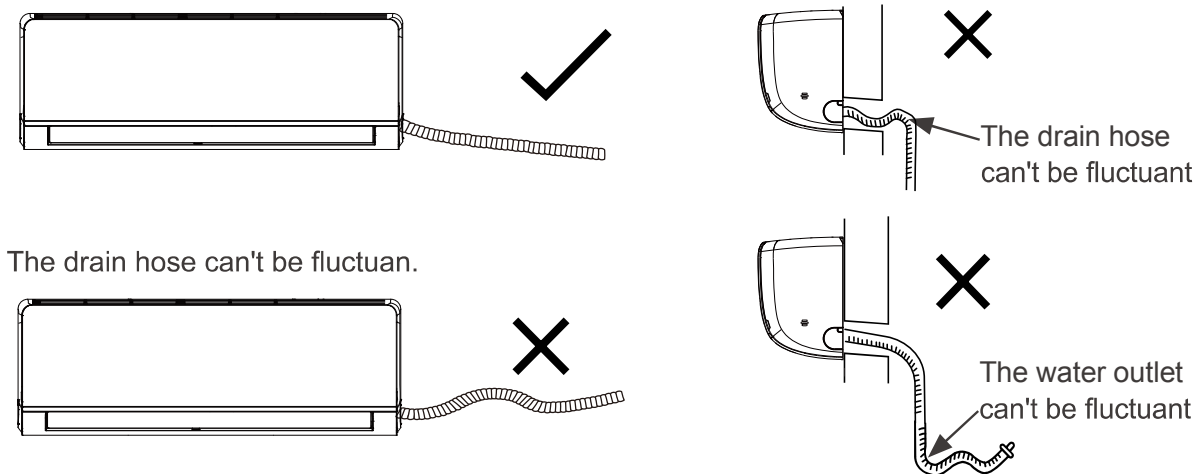

Step 7: Vacuum pumping

Use vacuum pump

1. Remove the valve caps on the liquid valve and gas valve and the nut of refrigerant charging vent.
2. Connect the charging hose of piezometer to the refrigerant charging vent of gas valve and then connect the other charging hose to the vacuum pump.
3. Open the piezometer completely and operate for 10-15min to check if the pressure of piezometer remains in -0.1MPa.
4. Close the vacuum pump and maintain this status for 1-2min to check if the pressure of piezometer remains in -0.1MPa. If the pressure decreases, there may be leakage.
5. Remove the piezometer, open the valve core of liquid valve and gas valve completely with inner hexagon spanner.
6. Tighten the screw caps of valve and refrigerant charging vent.
7. Reinstall the handle.

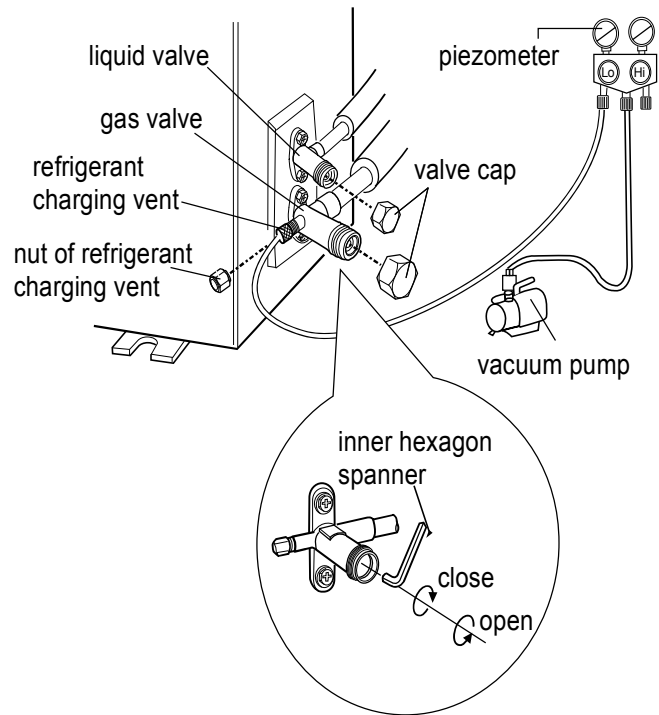

Step 8: Leakage detection

1. With leakage detector:

Check if there is leakage with leakage detector.

2. With soap water:

If leakage detector is not available, please use soap water for leakage detection.

Apply soap water at the suspected position and keep the soap water for more than 3min. If there are air bubbles coming out of this position, there's a leakage.

1.5 Check after installation

Check according to the following requirement after finishing installation.

Items to be checked	Possible malfunction
Has the unit been installed firmly?	The unit may drop, shake or emit noise
Have you done the refrigerant leakage test?	It may cause insufficient cooling(heating) capacity.
Is heat insulation of pipeline sufficient?	It may cause condensation and water dripping.
Is water drained well?	It may cause condensation and water dripping.
Is the voltage of power supply according to the voltage marked on the nameplate?	It may cause malfunction or damaging the parts.
Is electric wiring and pipeline installed correctly?	It may cause malfunction or damaging the parts.
Is the unit grounded securely?	It may cause electric leakage
Does the power cord follow the specification?	It may cause malfunction or damaging the parts.
Is there any obstruction in the air inlet and outlet?	It may cause insufficient cooling(heating) capacity.
The dust and sundries caused during installation are removed?	It may cause malfunction or damaging the parts.
The gas valve and liquid valve of connection pipe are open completely?	It may cause insufficient cooling(heating) capacity.

1.6 Test operation

1. Preparation of test operation

- The client approves the air conditioner.
- Specify the important notes for air conditioner to the client.

2. Method of test operation

- Put through the power, press ON/OFF button on the remote controller to start operation.
- Press MODE button to select AUTO, COOL, DRY, FAN and HEAT to check whether the operation is normal or not.
- If the ambient temperature is lower than 16 °C, the air conditioner can't start cooling.

1.7 Configuration of connection pipe

1. Standard length of connection pipe
 - 5m, 7.5m, 8m.
2. Min. length of connection pipe is 3m.
3. Max. length of connection pipe and max. high difference.

Cooling capacity	Max length of connection pipe	Max height difference	Cooling capacity	Max length of connection pipe	Max height difference
5000Btu/h(1465W)	15	5	24000Btu/h(7032W)	25	10
7000Btu/h(2051W)	15	5	28000Btu/h(8204W)	30	10
9000Btu/h(2637W)	15	5	36000Btu/h(10548W)	30	20
12000Btu/h(3516W)	20	10	42000Btu/h(12306W)	30	20
18000Btu/h(5274W)	25	10	48000Btu/h(14064W)	30	20

4. The additional refrigerant oil and refrigerant charging required after prolonging connection pipe
 - After the length of connection pipe is prolonged for 10m at the basis of standard length, you should add 5ml of refrigerant oil for each additional 5m of connection pipe.
 - The calculation method of additional refrigerant charging amount (on the basis of liquid pipe):

$$\text{Additional refrigerant charging amount} = \text{prolonged length of liquid pipe} \times \text{additional refrigerant charging amount per meter}$$
 - Basing on the length of standard pipe, add refrigerant according to the requirement as shown in the table. The additional refrigerant charging amount per meter is different according to the diameter of liquid pipe. See the following sheet.

Additional refrigerant charging amount for R22, R407C, R410A and R134a

Diameter of connection pipe		Outdoor unit throttle	
Liquid pipe(mm)	Gas pipe(mm)	Cooling only(g/m)	Cooling and heating(g/m)
Φ6	Φ9.52 or Φ12	15	20
Φ6 or Φ9.52	Φ16 or Φ19	15	50
Φ12	Φ19 or Φ22.2	30	120
Φ16	Φ25.4 or Φ31.8	60	120
Φ19	-	250	250
Φ22.2	-	350	350

1.8 Pipe expanding method

Improper pipe expanding is the main cause of refrigerant leakage. Please expand the pipe according to the following steps:

A: Cut the pipe

Confirm the pipe length according to the distance of indoor unit and outdoor unit. Cut the required pipe with pipe cutter.

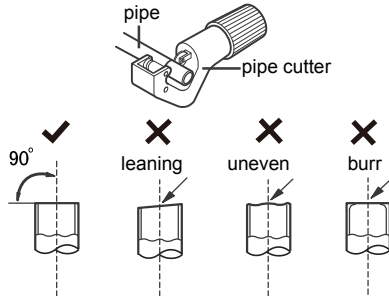

B: Remove the burrs

Remove the burrs with shaper and prevent the burrs from getting into the pipe.

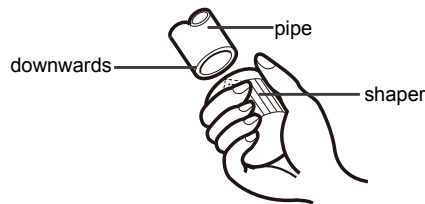

C: Put on suitable insulating pipe

D: Put on the union nut

Remove the union nut on the indoor connection pipe and outdoor valve; install the union nut on the pipe.

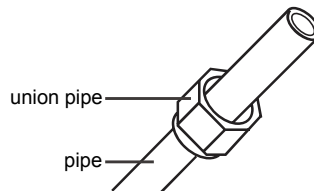

E: Expand the port

Expand the port with expander.

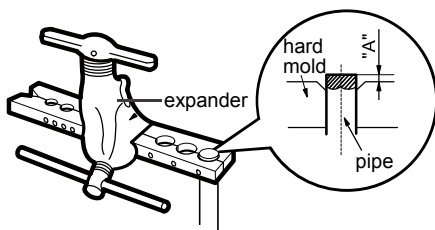

Note:

"A" is different according to the diameter, please refer to the sheet below:

Outer diameter(mm)	A(mm)	
	Max	Min
Φ6 - 6.35(1/4")	1.3	0.7
Φ9.52(3/8")	1.6	1.0
Φ12-12.7(1/2")	1.8	1.0
Φ15.8-16(5/8")	2.4	2.2

F: Inspection

Check the quality of expanding port.

If there is any blemish, expand the port again according to the steps above.

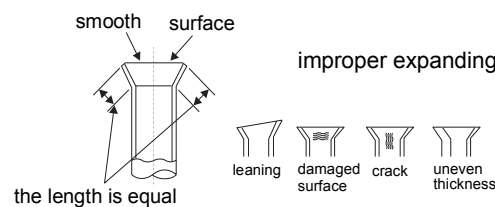

2. Function and Control

2.1 Remote Controller Operations

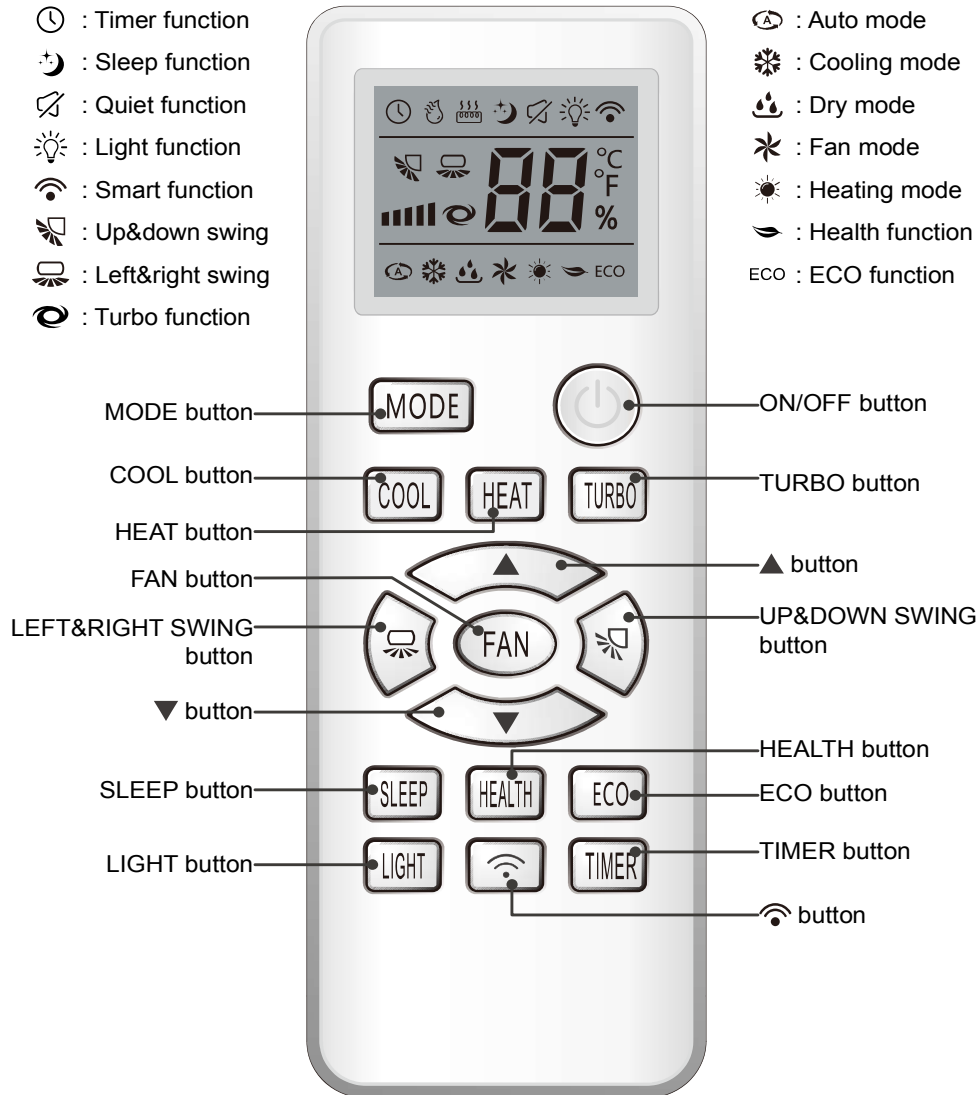

After connecting the power, the air conditioner will make a sound.

Power indicator is ON. After that, you can operate the air conditioner by using remote controller.

Under on status, pressing the button on the remote controller, the signal icon " " on the display of remote controller will blink once and the air conditioner will give out a "de" sound, which means the signal has been sent to the air conditioner. The display will show the corresponding set function icons.

Under off status, light and clock icon will be displayed on the display of remote controller (If timer on, timer off and light functions are set, the corresponding icons will be displayed on the display of remote controller at the same time).

ON/OFF button

Press this button can turn on or turn off the air conditioner.

MODE button

Press this button to select your required operation mode.



- When selecting auto mode, air conditioner will operate automatically according to ex-factory setting. Set temperature can't be adjusted and will not be displayed as well. Press "FAN" button can adjust fan speed. Press "↺" or "↻" button can adjust fan blowing angle.
- After selecting cooling mode, air conditioner will operate under cooling mode. Press "▲" or "▼" button to adjust set temperature. Press "FAN" button to adjust fan speed. Press "↺" or "↻" button to adjust fan blowing angle.
- When selecting dry mode, the air conditioner operates at fan1, fan speed can't be adjusted. Press "↺" or "↻" button to adjust fan blowing angle.
- When selecting fan mode, the air conditioner will only blow fan, no cooling and no heating. Press "FAN" button to adjust fan speed. Press "↺" or "↻" button to adjust fan blowing angle.
- When selecting heating mode, the air conditioner operates under heating mode. Press "▲" or "▼" button to adjust set temperature. Press "FAN" button to adjust fan speed. Press "↺" or "↻" button to adjust fan blowing angle. (Cooling only unit won't receive heating mode signal. If setting heating mode with remote control, press "ON/OFF" button can't start up the unit).

Note:

- For preventing cold air, after starting up heating mode, indoor unit will delay 1~5 minutes to blow air (actual delay time is depend on indoor ambient temperature).
- Set temperature range from remote control: 16~31°C;
Fan speed: auto, quiet, fan1, fan2, fan3, fan4, fan5, turbo, stepless speed.

COOL button

Press "COOL" button to turn the air conditioner on and start the cooling mode. At this status the air conditioner operates at auto fan speed and a setting temperature of 26°C.

HEAT button

Press "HEAT" button to turn the air conditioner on and start the heating mode. At this status the air conditioner operates at auto fan speed and a setting temperature of 22°C.

TURBO button

Press this button to turn on or turn off the turbo function in cool/heat/fan mode.

Note:

- Press "FAN" button the unit will quit this function.
- This function is no use in auto mode or dry mode.

▲ and ▼ button

Press "▲" or "▼" button once to increase or decrease 1°C of temperature. Holding "▲" or "▼" button, temperature on remote control will change quickly. On releasing button after setting is finished, temperature indicator on indoor unit will change accordingly.

(Temperature can't be adjusted under auto mode)

When setting TIMER ON, TIMER OFF, press "▲" or "▼" button to adjust time.

(Refer to "TIMER" button)

🌀 button

Press this button can turn on or turn off the left&right swing function. When left&right swing function is on, "🌀" icon is displayed on remote control.

🌀 button

Press this button can turn on or turn off the up&down swing function. When up&down swing function is on, "🌀" icon is displayed on remote control.

FAN button

Pressing this button can set fan speed circularly as: auto, quiet, fan1, fan2, fan3, fan4, fan5, turbo, stepless speed.

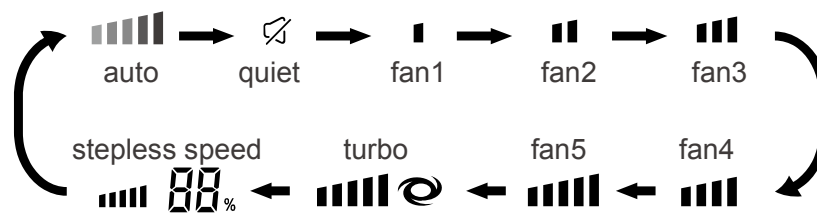

Note:

- In AUTO speed, air conditioner will select proper fan speed automatically according to ambient temperature.
- Fan speed under dry mode is fan1.
- No turbo fan speed under AUTO mode. No quiet fan speed under FAN mode.
- After entering the stepless speed function, users can adjust the fan speed according to the button "▲" or "▼".

SLEEP button

Press this button to turn on or turn off the Sleep function under cool, heat, dry mode. When Sleep function is on, "☾" icon is displayed on remote control.

Note:

- This function is off as defaulted after power on.
- It will be cleared after changing mode.
- It is no use under "Fan" mode and "Auto" mode.

HEALTH button

Press this button to turn on or turn off the health function. When health function is on, "🌿" icon is displayed on remote control.

Note: This function is not available for some models.

ECO button

In cooling mode, press this button can turn on or turn off the ECO function. When ECO function is on, "ECO" icon is displayed on remote control.

Note:

- Air conditioner will operate at auto speed. Set temperature can't be adjusted.
- Under cooling mode, sleep function can not work with ECO function together at the same time.
- Change mode will exit the ECO function.
- No turbo function under ECO condition.

TIMER button

Press "TIMER" button to set the time of turning on and turning off. When the LCD screen of remote control displays "🕒" and the "88" light flashes, press "▲" and "▼" to adjust the time to the required value and then press "TIMER" again to confirm.

Note:

- The range of time setting is from 1 to 24 hours and the scale is 1 hour.
- If there is no operation within 5 seconds after entering the setting status, the status will be exited.
- After completing the setting process, the LCD screen will resume the displaying at the status of turning on.

LIGHT button

Press this button can turn on or turn off the light for indoor unit's display. When light function is on, "💡" icon is displayed on remote control.

button

Press this button to turn on or turn off the SMART function. When smart function is on, "  " icon is displayed on remote control. For more details, please see for Smart APP User Guide.

Child lock function

Press " ▲ " and " ▼ " simultaneously to turn on or turn off child lock function. After turn on the child lock function, no matter which button is pressed, only temperature display will flash.

- If match with MULTI-S outdoor unit, when units has malfunction and need to inquire the address to maintainance, the step is as below:
Remote control aims to the indoor display, press "Light" and "-" buttons at the same time for 3s , then will display the indoor unit address(1~5) for 3s.



OMEGA
ENVIRONMENTAL
TECHNOLOGIES LLC.

17702 Mitchell North, #101
Irvine, CA. 92614 .USA
Tel: 714 795 2830
Fax: 714 966 1646
info@otecomega.com
www.otecomega.com

OTECTM
AIR CONDITIONING

Showroom & Technology Center
11380 Interchange Circle North
Miramar, FL 33025 .USA
Tel: 305 901 1270
Fax: 954 212 8280
info@otecvrf.com
www.otecvrf.com

IEWV(CHV)I3A-IM1Y0622